

AH. 197. A.

*Austin-Healey '100-Six' with hood raised.*

AUSTIN-HEALEY '100-SIX'

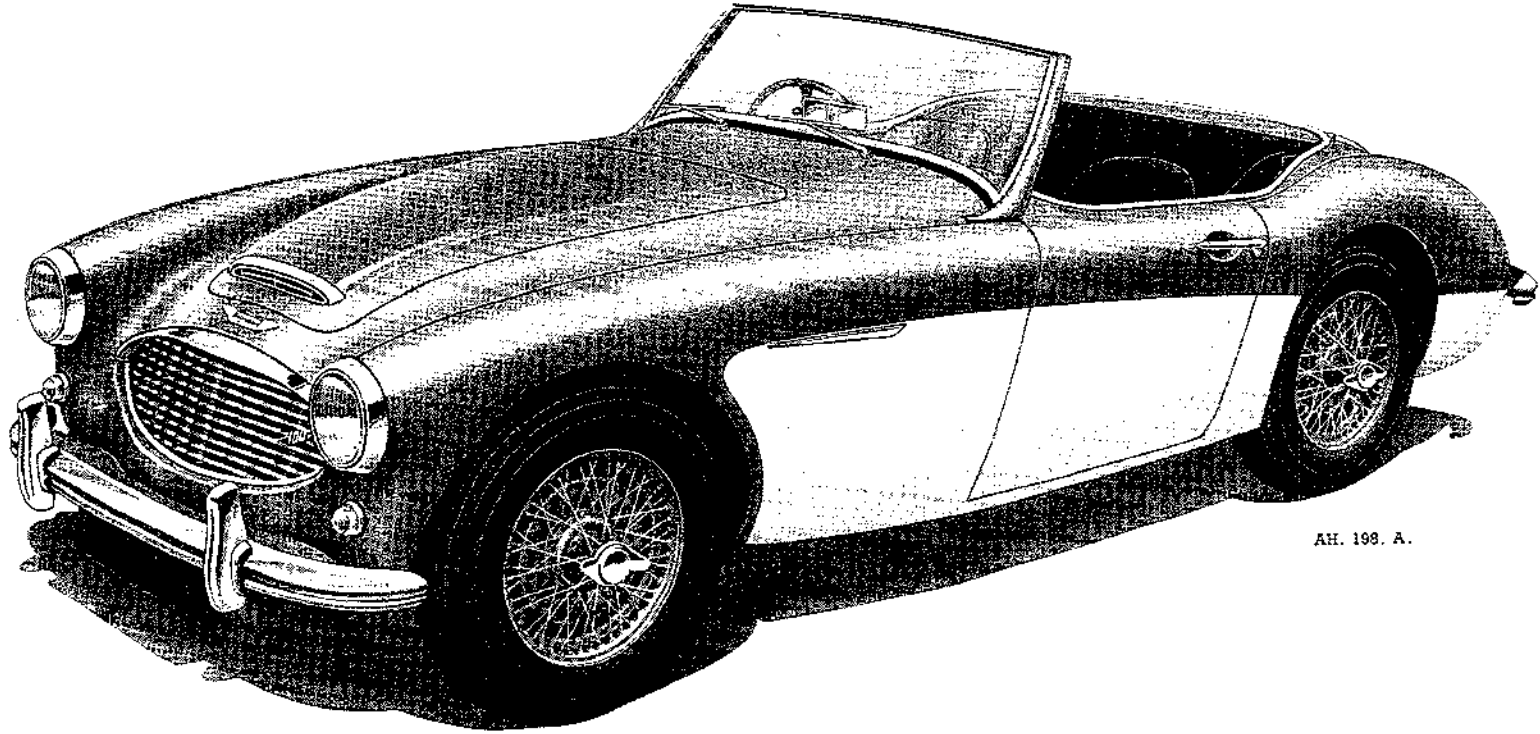

AH. 198. A.

*Austin-Healey '100-Six' with hood lowered.*

AUSTIN-HEALEY '100-SIX'

# AUSTIN-HEALEY '100-SIX'

---

## CONTENTS

Introduction	...	...	...	...	...	...	...	Page	ii
General Data	...	...	...	...	...	...	...	"	vii
Regular Attentions	...	...	...	...	...	...	...	"	xv
Engine	...	...	...	...	...	...	...	Section	A
Ignition	...	...	...	...	...	...	...	"	B
Cooling System	...	...	...	...	...	...	...	"	C
Fuel System	...	...	...	...	...	...	...	"	D
Clutch	...	...	...	...	...	...	...	"	E
Gearbox	...	...	...	...	...	...	...	"	F
Overdrive	...	...	...	...	...	...	...	"	G
Propeller Shaft	...	...	...	...	...	...	...	"	H
Rear Axle and Suspension	...	...	...	...	...	...	...	"	J
Steering	...	...	...	...	...	...	...	"	K
Front Suspension and Front Hubs	...	...	...	...	...	...	...	"	L
Brakes	...	...	...	...	...	...	...	"	M
Electrical System	...	...	...	...	...	...	...	"	N
Wheels and Tyres	...	...	...	...	...	...	...	"	O
Bodywork	...	...	...	...	...	...	...	"	P
Lubrication	...	...	...	...	...	...	...	"	Q



## GENERAL DATA

### ENGINE

Number of cylinders	...	...	...	...	...	Six
Capacity	...	...	...	...	...	2,639 c.c. (161 cu. ins.)
B.H.P.	...	...	...	...	...	102 at 4,600 r.p.m.
Torque	...	...	...	...	...	142 at 2,400 r.p.m.
Bore	...	...	...	...	...	3.125 in. (79.4 mm.)
Stroke	...	...	...	...	...	3.5 in. (89.0 mm.)
Compression ratio	...	...	...	...	...	8.25 : 1
First oversize bore	...	...	...	...	...	+ .010 in. (.254 mm.)
Second oversize bore	...	...	...	...	...	+ .020 in. (.508 mm.)
Third oversize bore	...	...	...	...	...	+ .030 in. (.762 mm.)
Fourth oversize bore	...	...	...	...	...	+ .040 in. (1.016 mm.)
Firing order	...	...	...	...	...	1, 5, 3, 6, 2, 4.
Piston type	...	...	...	...	...	Low expansion aluminium alloy
Piston clearance at skirt	...	...	...	...	...	.0008 in. (.0203 mm.) to .002 in. (.0508 mm.)
Piston ring gap (fitted)	...	...	...	...	...	.009 in. (.229 mm.) to .014 in. (.356 mm.) in 3.125 in. dia. gauge
Piston rings :						
1st ring	...	...	...	...	...	Plain
2nd ring	...	...	...	...	...	Taper
3rd ring	...	...	...	...	...	Taper
4th ring	...	...	...	...	...	Slotted scraper
Width of plain and taper rings	...	...	...	...	...	.0928 in. (2.3571 mm.) to .0938 in. (2.3825 mm.)
Width of slotted scraper ring	...	...	...	...	...	.1865 in. (4.7371 mm.) to .1875 in. (4.7625 mm.)
Oil capacity, sump	...	...	...	...	...	11 imp. pints (13.2 U.S. pints, 6.25 litres) ex- cluding filter
Filter capacity	...	...	...	...	...	1½ imp. pints (1.5 U.S. pints, 0.84 litres)
Oil pressure :						
Running (hot)	...	...	...	...	...	55 to 60 lb./sq. in. (3.9 to 4.2 kg./cm. <sup>2</sup> )
Idling	...	...	...	...	...	25 to 30 lb./sq. in. (1.758 to 2.109 kg./cm. <sup>2</sup> )
Gudgeon pin type (early models)	...	...	...	...	...	Clamped in rod
Gudgeon pin type (Engine No. 40501 and onwards)	...	...	...	...	...	Fully floating
Gudgeon pin diameter	...	...	...	...	...	.8748 to .8750 in. (22.22 to 22.224 mm.)
Fit in piston (clearance)	...	...	...	...	...	.0000 in. to +.0004 in. (0 to .0102 mm.)
Crankpin diameter (standard)	...	...	...	...	...	2.000 in. to 2.0005 in. (50.8 to 50.8127 mm.)
Regrind sizes	...	...	...	...	...	.010 in. (.254 mm.) .020 in. (.508 mm.) .030 in. (.762 mm.) and .040 in. (1.016 mm.)
Connecting rod, type	...	...	...	...	...	Steel stamping
Connecting rod—length between centres	...	...	...	...	...	6.601 in. to 6.605 in. (167.7 to 151.8 mm.)
Connecting rod—type of bearing	...	...	...	...	...	Steel backed white metal lined
Connecting rod—side clearance	...	...	...	...	...	.004 in. (.1016 mm.) to .007 in. (.1778 mm.)
Connecting rod—diametral clearance	...	...	...	...	...	.0005 in. (.0127 mm.) to .002 in. (.0508 mm.)
Number of main bearings	...	...	...	...	...	Four
Type	...	...	...	...	...	Steel backed white metal lined
Standard journal diameter	...	...	...	...	...	2.5215 in. (64.05 mm.) to 2.5315 in. (64.30 mm.)
Regrind sizes	...	...	...	...	...	.010 in. (.254 mm.) .020 in. (.508 mm.) .030 in. (.762 mm.) and .040 in. (1.016 mm.)
Length of main bearings	...	...	...	...	...	1.495 in. (37.97 mm.) to 1.535 in. (38.23 mm.)
Main bearing running clearance	...	...	...	...	...	.0013 in. (.033 mm.) to .0028 (.0711 mm.)
Crankshaft end thrust taken on	...	...	...	...	...	2nd main bearing
Number of camshaft bearings	...	...	...	...	...	4
Camshaft bearing type	...	...	...	...	...	Pre-formed, steel backed white metal
Camshaft bearing clearance	...	...	...	...	...	.001 in. (0.0254 mm.) to .002 in. (.0508 mm.)

## GENERAL DATA

Camshaft journal diameters :							
Front	...	...	...	...	...	...	1.788 $\frac{1}{4}$ to 1.789 $\frac{1}{4}$ in. (45.43425 to 45.44695 mm.)
Centre (front)	...	...	...	...	...	...	1.768 $\frac{1}{4}$ to 1.769 $\frac{1}{4}$ in. (44.92625 to 44.93895 mm.)
Centre (rear)	...	...	...	...	...	...	1.748 $\frac{1}{4}$ to 1.749 $\frac{1}{4}$ in. (44.41825 to 44.43095 mm.)
Rear	...	...	...	...	...	...	1.728 $\frac{1}{4}$ to 1.729 $\frac{1}{4}$ in. (43.91025 to 43.92295 mm.)
Camshaft end thrust taken on	...	...	...	...	...	...	Front end
Camshaft end float	...	...	...	...	...	...	.003 in. (.0762 mm.) to .006 in. (.152 mm.)
Camshaft drive type	...	...	...	...	...	...	Duplex chain .375 in. (9.525 mm.) pitch 62 pitches, endless
Valve timing marking	...	...	...	...	...	...	Adjoining gear teeth are marked
Exhaust valve :							
Throat diameter	...	...	...	...	...	...	1.188 in. (30.1752 mm.) to 1.193 in. (30.302 mm.)
Head diameter	...	...	...	...	...	...	1.4150 in. (35.94 mm.) to 1.420 (36.07 mm.)
Stem diameter	...	...	...	...	...	...	.34175 in. (8.68 mm.) to .34225 in. (8.693 mm.)
Inlet valve :							
Throat diameter	...	...	...	...	...	...	1.375 in. (34.925 mm.) to 1.380 in. (34.05 mm.)
Head diameter	...	...	...	...	...	...	1.683 in. (42.748 mm.) to 1.693 in. (43 mm.)
Stem diameter	...	...	...	...	...	...	.34175 in. (8.68 mm.) to .34225 in. (8.693 mm.)
Seat angles :							
Inlet	...	...	...	...	...	...	30°
Exhaust	...	...	...	...	...	...	45°
Timing :							
Inlet valve opens	...	...	...	...	...	...	5° B.T.D.C.
Inlet valve closes	...	...	...	...	...	...	45° A.B.D.C.
Exhaust valve opens	...	...	...	...	...	...	40° B.B.D.C.
Exhaust valve closes	...	...	...	...	...	...	10° A.T.D.C.
Clearance at valve for timing (cold)	...	...	...	...	...	...	.024 in. (.6096 mm.)
Actual running clearance at valve...	...	...	...	...	...	...	.012 in. (.3048 mm.) hot
Valve guides	...	...	...	...	...	...	Removable
Valve guide lengths :							
Inlet	...	...	...	...	...	...	2.266 in. (57.556 mm.)
Exhaust	...	...	...	...	...	...	2.578 in. (65.48 mm.)
Valve spring :							
Outer :							
Free length	...	...	...	...	...	...	2.047 in. (51.99 mm.)
Fitted length	...	...	...	...	...	...	1.607 in. (40.82 mm.) load, 54.2 lb. (24.58 kg.)
Number of effective coils	...	...	...	...	...	...	4 $\frac{1}{2}$
Wire gauge	...	...	...	...	...	...	.1562 in. (3.97 mm.)
Core diameter	...	...	...	...	...	...	.993 (25.22 mm.) to 1.007 in. (25.578 mm.)
Inner :							
Free length	...	...	...	...	...	...	1.969 in. (50.113 mm.)
Fitted length	...	...	...	...	...	...	1.517 in. (38.53 mm.) load, 25.3 lb. (11.476 kg.)
Number of effective coils	...	...	...	...	...	...	6 $\frac{1}{2}$
Wire gauge	...	...	...	...	...	...	.110 in. (2.794 mm.)
Core diameter	...	...	...	...	...	...	.715 in. (18.16 mm.) to .730 in. (18.54 mm.)

### TORQUE WRENCH SETTINGS

Cylinder head stud nuts	...	...	...	...	...	75 lb.ft. (10.4 kg.m.)
Connecting rod big end bolts	...	...	...	...	...	50 lb.ft. (6.913 kg.m.)
Connecting rod clamp bolt	...	...	...	...	...	50 lb.ft. (6.913 kg.m.)
Main bearing stud nuts	...	...	...	...	...	75 lb.ft. (10.4 kg.m.)

## GENERAL DATA

### IGNITION

Type ... ..	Lucas 12-volt coil
Distributor type ... ..	Lucas DM6A
Direction of rotation ... ..	Anti-clockwise at rotor arm
Contact breaker gap ... ..	·014 in. to ·016 in. (.356 to .406 mm.)
Static setting ... ..	6° (Crankshaft) B.T.D.C.
Maximum advance ... ..	35° (Crankshaft) B.T.D.C.
Coil type ... ..	Lucas type HA 12
Sparking plug type ... ..	Champion NA8—14 mm. Long Reach
Sparking plug gap ... ..	·024 in. (.6096 mm.) to ·026 in. (.660 mm.)

### COOLING SYSTEM

Capacity ... ..	20 Imp. pints (24 U.S. pints, 10·8 litres)
Circulation ... ..	Pump and thermostat

### FUEL SYSTEM

Fuel delivery... ..	S.U. electric, type H.P.
Carburettor type ... ..	Twin S.U. horizontal H.4.
Needle (normal) ... ..	A.J.
Jet size ... ..	·090 in. (2·286 mm.)
Tank capacity ... ..	12 Imp. gallons (54·5 litres)
Air cleaner ... ..	Twin "Pancake" type

### CLUTCH

Make ... ..	Borg and Beck
Type ... ..	Single dry plate
Diameter ... ..	9 in. (229 mm.)
Total friction area ... ..	36·5 sq. in. (235 cm. <sup>2</sup> ) × 2
Thickness of friction linings ... ..	·150 (3·81 mm.)
Release bearings ... ..	Special carbon graphite or copper carbon graphite
Number of springs ... ..	9
Total axial spring pressure ... ..	1215 to 1305 lb. (551 to 592 kg.)
Distance thrust race to thrust plate ... ..	·10 in. (2·54 mm.)
Thrust plate travel to fully released position ... ..	·42 to ·47 in. (10·66 to 11·93 mm.)

### GEARBOX

Type ... ..	Synchromesh on 2nd, 3rd and top
Type of gear ... ..	Helical constant mesh
Type overdrive (optional extra) ... ..	Laycock de Normanville electrically controlled
Gear ratios :	
First ... ..	3·076 : 1
Second ... ..	1·913 : 1
Third ... ..	1·333 : 1
Overdrive, third ... ..	1·037 : 1
Fourth ... ..	Direct
Overdrive, fourth ... ..	·778 : 1
Reverse ... ..	4·16 : 1
Overall Gear Ratios—	
Standard Box :	
First ... ..	12·027 : 1
Second ... ..	7·48 : 1
Third ... ..	5·212 : 1
Fourth ... ..	3·91 : 1
Reverse ... ..	16·4 : 1

## GENERAL DATA

### Overall Gear Ratios—continued.

Including overdrive :								
First ... ..	...	...	...	...	...	...	...	12.6 : 1
Second ... ..	...	...	...	...	...	...	...	7.84 : 1
Third ... ..	...	...	...	...	...	...	...	5.47 : 1
Third and overdrive	...	...	...	...	...	...	...	4.24 : 1
Fourth ... ..	...	...	...	...	...	...	...	4.1 : 1
Fourth and overdrive	...	...	...	...	...	...	...	3.19 : 1
Reverse ... ..	...	...	...	...	...	...	...	17.1 : 1
Layshaft bearing :								
Type ... ..	...	...	...	...	...	...	...	Needle roller
Number of rollers	...	...	...	...	...	...	...	46
Length of roller	...	...	...	...	...	...	...	1.551 in. (39.6 mm.)
Diameter of roller	...	...	...	...	...	...	...	3.118 in. (3 mm.)
Mainshaft bearing :								
Make ... ..	...	...	...	...	...	...	...	R. & M.
Type ... ..	...	...	...	...	...	...	...	MJ.35
Size ... ..	...	...	...	...	...	...	...	1.39 × 3.15 × .827 in. (35 × 80 × 21 mm.)
First motion shaft bearing :								
Make ... ..	...	...	...	...	...	...	...	R. & M.
Type ... ..	...	...	...	...	...	...	...	IM J40G ///
Size ... ..	...	...	...	...	...	...	...	1.58 × 3.55 × .905 in. (40 × 90 × 23 mm.)
Oil capacity (standard box)	...	...	...	...	...	...	...	4 pints (4.8 U.S. pints, 2.27 litres)
Oil capacity (overdrive fitted)	...	...	...	...	...	...	...	5½ Imp. pints (6.3 U.S. pints, 2.98 litres)

### REAR AXLE

Type ... ..	...	...	...	...	...	...	...	¾ floating
Ratio :								
Standard ... ..	...	...	...	...	...	...	...	3.91 : 1
With overdrive	...	...	...	...	...	...	...	4.1 : 1
Final drive ... ..	...	...	...	...	...	...	...	Hypoid bevel
Teeth on crown wheel :								
Standard ... ..	...	...	...	...	...	...	...	43
With overdrive	...	...	...	...	...	...	...	41
Teeth on pinion :								
Standard ... ..	...	...	...	...	...	...	...	11
With overdrive	...	...	...	...	...	...	...	10
Crown wheel/pinion backlash	...	...	...	...	...	...	...	Marked on crown wheel
Oil capacity ... ..	...	...	...	...	...	...	...	3 Imp. pints (1.70 litres, 3.6 U.S. pints)

### REAR SPRINGS

Type ... ..	...	...	...	...	...	...	...	Semi-elliptic
Number of leaves	...	...	...	...	...	...	...	7
Thickness of leaves	...	...	...	...	...	...	...	6 at $\frac{3}{16}$ in. and 1 at $\frac{5}{32}$ in.
Width ... ..	...	...	...	...	...	...	...	1½ in.
Deflection ... ..	...	...	...	...	...	...	...	4 in. ± ½ in.
Loaded camber	...	...	...	...	...	...	...	½ in. ± ½ in. negative
Number of zinc leaves	...	...	...	...	...	...	...	3 ( $\frac{1}{32}$ in. thickness)

### STEERING

Make ... ..	...	...	...	...	...	...	...	Cam gears
Ratio ... ..	...	...	...	...	...	...	...	14 : 1
Track toe-in ... ..	...	...	...	...	...	...	...	$\frac{1}{16}$ in. to $\frac{1}{8}$ in. (1.5 to 3.17 mm.)



## GENERAL DATA

### SUSPENSION

Front :									
Type ... ..	...	...	...	...	...	...	...	...	Independent by coil spring and wishbones
Castor angle ... ..	...	...	...	...	...	...	...	...	1 $\frac{3}{4}$ °
Camber angle ... ..	...	...	...	...	...	...	...	...	1°
Swivel pin inclination ... ..	...	...	...	...	...	...	...	...	6 $\frac{1}{2}$ °
Rear :									
Type ... ..	...	...	...	...	...	...	...	...	Semi-elliptic underslung leaf-springs with pan-hard rod.
Shock absorbers :									
Type ... ..	...	...	...	...	...	...	...	...	Lever hydraulic

### BRAKES

Type ... ..	...	...	...	...	...	...	...	...	Girling hydraulic two leading shoes front.
Drum diameter ... ..	...	...	...	...	...	...	...	...	11 in. (280 mm.)
Total frictional area ... ..	...	...	...	...	...	...	...	...	188 sq. in. (1213 sq. cm.)
Shoe lining width ... ..	...	...	...	...	...	...	...	...	2 $\frac{1}{4}$ in. (57 mm.)
Shoe lining length :									
Front ... ..	...	...	...	...	...	...	...	...	10·4 in. (265·6 mm.)
Rear ... ..	...	...	...	...	...	...	...	...	10·4 in. (265·6 mm.)
Shoe lining thickness ... ..	...	...	...	...	...	...	...	...	·167 to ·174 in. (4·24 to 4·42 mm.)
Pedal free movement ... ..	...	...	...	...	...	...	...	...	$\frac{1}{8}$ in. (3·175 mm.)
Handbrake ... ..	...	...	...	...	...	...	...	...	Mechanical, rear wheels only

### ELECTRICAL

Battery									
Type :									
Home (standard) ... ..	...	...	...	...	...	...	...	...	GTW 9A
Dry charged (export) ... ..	...	...	...	...	...	...	...	...	GTZ 9A
Voltage ... ..	...	...	...	...	...	...	...	...	12
Capacity :									
10 hour rate ... ..	...	...	...	...	...	...	...	...	51 amp.hr.
20 hour rate ... ..	...	...	...	...	...	...	...	...	58 amp.hr.
Electrolyte to fill one cell ... ..	...	...	...	...	...	...	...	...	1 pint
Initial charging current ... ..	...	...	...	...	...	...	...	...	3·5 amp.
Normal recharge current ... ..	...	...	...	...	...	...	...	...	5 amp.
Master switch ... ..	...	...	...	...	...	...	...	...	Lucas type ST330

\* Specific gravity of electrolyte for filling uncharged batteries corrected to 60°F. (15·6°C.).

GTW (Wood Separators)									
Below 80°F. (27°C.) ... ..	...	...	...	...	...	...	...	...	Filling 1·35
Below 80°F. (27°C.) ... ..	...	...	...	...	...	...	...	...	Fully charged 1·28 to 1·30
80° to 100°F. (27° to 38°C.) ... ..	...	...	...	...	...	...	...	...	Filling 1·32
80° to 100°F. (27° to 38°C.) ... ..	...	...	...	...	...	...	...	...	Fully charged 1·25 to 1·27
Above 100°F. (38°C.) ... ..	...	...	...	...	...	...	...	...	Filling 1·30
Above 100°F. (38°C.) ... ..	...	...	...	...	...	...	...	...	Fully charged 1·22 to 1·24

\* Specific gravity of electrolyte for filling "Dry Charged" batteries corrected to 60°F. (15·6°C.).

Below 90°F. (32°C.) ... ..	...	...	...	...	...	...	...	...	Filling 1·27
Below 90°F. (32°C.) ... ..	...	...	...	...	...	...	...	...	Fully charged 1·27 to 1·29
Above 90°F. (32°C.) ... ..	...	...	...	...	...	...	...	...	Filling 1·21
Above 90°F. (32°C.) ... ..	...	...	...	...	...	...	...	...	Fully charged 1·21 to 1·23

## GENERAL DATA

---

† Maximum permissible electrolyte temperature during charge.

For ambient temperature of :

Below 80°F. (27°C.)	100°F. (38°C.)
80° to 100°F. (27°C. to 38°C.)	110°F. (43°C.)
Above 100°F. (38°C.)	120°F. (49°C.)

\* The specific gravity of the electrolyte varies with the temperature for convenience in comparing specific gravities they are always corrected to 60°F., which is adopted as reference temperature. The method of correction is as follows :—

For every 5° below 60°F. deduct .002 from the observed reading to obtain the true specific gravity at 60°F.  
For every 5° above 60°F. add .002 to the observed reading to obtain the true specific gravity at 60°F.

† The temperature must be that actually indicated by a thermometer immersed in the electrolyte and not the ambient temperature.

### Generator

Type	Lucas C45 PV-5
Cutting-in speed	1,100 to 1,250 generator r.p.m.
Maximum output	22 amps., 13.5 volts at 1700 to 1900 generator r.p.m.
Field resistance	6 ohms.

### Starting Motor

Type	Lucas M418 G
Lock torque	17 lb.ft. (1.2858 kg.m.) at 440 to 460 amps. and 7.0 to 7.4 volts
Light running current	45 amps. at 7,400 to 8,500 r.p.m.
Solenoid switch	Lucas type, ST 950

### Overdrive (optional, extra)

Control switch	Lucas type 2TS
Transmission gear solenoid	Lucas type TGS1
Relay—overdrive	Lucas type SB 40-1
Interrupter switch	Lucas type 5510-1
Rotary throttle switch	Lucas type RTS1

### Control Box

Type	Lucas RB 106/2
Cut-out :	
Cut-in voltage	12.7 to 13.3 volts
Drop off voltage	8.5 to 11 volts
Reverse current	3.5 to 5 amps.

### Regulator

Setting on open circuit at 68°F. (20°C.) ... 16.0 to 16.6 volts at 3,000 generator r.p.m

**Note:** For circuit temperature other than 20°C. the following allowances should be made to the above setting.

For every 10°C. (18°F.) above 20° subtract 0.1 volt.

For every 10°C. (18°F.) below 20° add 0.1 volt.

### Windscreen Wiper

Type	Lucas DR2
Normal running current	2.3 to 3.1 amp. at 12 volts.
Stall current (motor hot)	8 amp.
Stall current (motor cold)	14 amp.
Armature resistance (adjacent commutator segments)	0.34 to 0.41 ohms.
Field resistance	12.8 to 14.00 ohms.

*N.B.*—On some high output motors usually identified by a red insulating piece above the terminals, the field resistance is 8.0 to 11.5 ohms.

## GENERAL DATA

---

Fuse Unit								
Type (two live and two spare fuses)	...	...	...	...	...	...	...	Lucas SF6
Fuses								
A1—A2	...	...	...	...	...	...	...	50 amp.
A3—A4	...	...	...	...	...	...	...	35 amp.
Sidelamps								
Type	...	...	...	...	...	...	...	Lucas model 594
Headlamps								
Type	...	...	...	...	...	...	...	Lucas model F700
Stop-Tail Lamps								
Type	...	...	...	...	...	...	...	Lucas model 594
Number Plate Illumination								
Type	...	...	...	...	...	...	...	Lucas model 467/2
Bulbs								
Headlamps, R.H.D. vehicles								
Type	...	...	...	...	...	...	...	Lucas No. 354, pre-focus
Voltage	...	...	...	...	...	...	...	12
Wattage	...	...	...	...	...	...	...	42/36
L.H.D. vehicles (not Europe)								
Type	...	...	...	...	...	...	...	Lucas No. 355, pre-focus
Voltage	...	...	...	...	...	...	...	12
Wattage	...	...	...	...	...	...	...	42/36
L.H.D. vehicles (Europe except France)								
Type	...	...	...	...	...	...	...	Lucas No. 370, pre-focus
Voltage	...	...	...	...	...	...	...	12
Wattage	...	...	...	...	...	...	...	45/40
Sidelamps (combined flashing indicators)								
Type	...	...	...	...	...	...	...	Lucas No. 380
Voltage	...	...	...	...	...	...	...	12
Wattage	...	...	...	...	...	...	...	21/6
Stop/Tail Lamps								
Type	...	...	...	...	...	...	...	Lucas No. 380
Voltage	...	...	...	...	...	...	...	12
Wattage	...	...	...	...	...	...	...	21/6
Number Plate Lamps								
Type	...	...	...	...	...	...	...	Lucas No. 989
Voltage	...	...	...	...	...	...	...	12
Wattage	...	...	...	...	...	...	...	6
Ignition, Main Beam Warning and Panel Lights								
Type	...	...	...	...	...	...	...	Lucas No. 987
Voltage	...	...	...	...	...	...	...	12
Wattage	...	...	...	...	...	...	...	2.2

## GENERAL DATA

---

### Flashing Indicator Unit

Type ... ..	Lucas FL5
Voltage ... ..	12

### TYRE SIZES AND INFLATION PRESSURES

Tyre sizes ... ..	5.90—15 tubeless or 5.90—15 road speed (optional alternative).
Pressures :	
Front ... ..	20 lb./sq. in. (1.41 kg./cm. <sup>2</sup> )
Rear ... ..	23 lb./sq. in. (1.62 kg./cm. <sup>2</sup> )

### WHEELS

Type ... ..	15×4J ventilated steel disc or 15×4J wire (optional alternative).
-------------	---

### DIMENSIONS

Wheelbase ... ..	7 ft. 8 in. (2.34 m.)
Overall length ... ..	13 ft. 1½ in. (4.00 m.)
Overall height (hood raised) ... ..	4 ft. 1 in. (1.24 m.)
Overall height (hood lowered) ... ..	3 ft. 10 in. (1.17 m.)
Overall width ... ..	5 ft. 0½ in. (1.54 m.)
Height over scuttle ... ..	2 ft. 11⅞ in. (0.91 m.)
Ground clearance ... ..	5½ in. (0.14 m.)
Track, front ... ..	4 ft. 0¾ in. (1.24 m.)
Track, rear ... ..	4 ft. 2 in. (1.27 m.)
Turning circle ... ..	35 ft. 0 in. (10.67 m.)
Approximate weight (with overdrive and wire wheels) ... ..	2,436 lb. (1105 kg.)

---

## REGULAR ATTENTIONS

### POST DELIVERY CHECK

Austin Dealers are under agreement to carry out "Post Delivery Check" once during the period of the first 500 miles (800 km.) running or as soon as possible afterwards, on Austin vehicles purchased from them when they will, without charge, except for materials used :—

- (1) Change oil in the engine, gearbox and rear axle.
- (2) Check oil level in the steering box and top up if necessary.
- (3) Lubricate all chassis points.
- (4) Check and lubricate all door catches, hinges, striking plates and bonnet safety catch.
- (5) Tighten nuts of cylinder head and valve rocker shaft brackets and manifold to recommended pressure.
- (6) Check tappet clearance and reset if necessary.
- (7) Tighten fan belt if necessary.
- (8) Check all water connections and tighten clips if necessary.
- (9) Examine and clean the carburetters and reset the slow running adjustment.
- (10) Check all fuel pipe union nuts.
- (11) Examine and adjust if necessary sparking plug and distributor points.
- (12) Check working of automatic ignition control and reset if necessary.
- (13) Check front wheel alignment and steering connections and adjust if necessary.
- (14) Check and adjust, if necessary, clutch free pedal movement.
- (15) Check braking system functionally, adjust and bleed if necessary.
- (16) Check brake and clutch fluid reservoirs and top up if necessary.
- (17) Check electrical system functionally, examine battery and top up if necessary. Clean and tighten terminals.
- (18) Check tightness of all nuts and bolts on wings, shock absorbers, springs, wheel nuts, universal joints, etc.
- (19) Inspect shock absorbers for leaks, examine oil levels and top up if necessary.
- (20) Check tyre pressures.
- (21) Check operation of all instruments.
- (22) Road test.

### DAILY

#### Engine

Check the level of the oil in the sump and top up if necessary to the "MAX." mark on the dipstick. The oil filler is in the valve rocker cover and the dipstick is on the right-hand side of the engine.

After adding oil allow a few seconds to elapse for the oil to reach the sump, from the valve rocker cover, before checking the level.

#### Radiator

Check the level in the radiator and top up if necessary. Fill to the bottom of the filler cap well, when the engine is cold.

*N.B.*—Under no circumstances should the radiator filler cap be removed if the coolant temperature is above boiling point or if the engine is running.

#### Tyres

Check all tyre pressures, using a tyre gauge, and inflate if necessary, to recommended pressures. Ensure the valves are fitted with screw caps, inspect the tyres for possible damage and wipe off any oil or grease.

See section on tyres in General Data for correct pressures.

### EVERY 1,000 MILES

(1600 km.)

#### Gearbox and Overdrive

Check the oil level and top up if necessary. For access take out inspection panel in the top right hand side of the gearbox cover when the filler plug will be accessible.

Remove the combined dipstick and filler plug and fill up to the correct level.

#### Rear Axle

Check the oil level and replenish if necessary. The correct grade of oil should be injected into the axle casing from underneath, using the adaptor on the oil gun.

First remove the plug, which is located on the rear side of the axle, then place the end of the adaptor into the oil hole, and inject with oil.

The plug also serves as an oil level indicator. Therefore do not replace the plug at once, but give the oil time to run out if too much has been injected. This is most important because if the rear axle is overfilled the lubricant may leak through to the brakes and render them ineffective. Wipe away excess oil from casing.

#### Propeller Shaft Splines

Oil the nipple on the sliding yoke at the gearbox end of the propeller shaft. To get at this yoke lift out the gearbox cover.

#### Universal Joints

Lubricate the propeller shaft universal joints. The front joint is best lubricated from above after the gearbox cover has been removed. The rear joint is lubricated from below. Move the car to bring the nipples to the required positions.

Also test the flange bolts and tighten if these have worked loose.

## REGULAR ATTENTIONS

---

### Steering Connections

Apply the oil gun to the steering centre cross tube nipples, and the steering side cross tube nipples and top up the steering idler via the oil plug orifice.

*N.B.*—On no account should the steering idler be overlooked, as lack of lubricant in this component may cause serious breakdown due to the additional load placed on the steering box.

### Steering Box

The steering box should be topped up with oil, using the oil gun adaptor. Take out the hexagon plug on the side of the steering box to inject the oil. Make certain that grit does not enter the casing during the operation, and wipe away any excess oil. To facilitate this attention it is advisable to remove the road wheel.

### Steering Column

Lubricate the felt bush at the top of the steering column with a few drops of engine oil. To gain access to the bush adjust the steering wheel to its full extended position, then collapse the spring at the base of the steering wheel hub when the bush will be exposed.

### Fulcrum Pins

Apply the oil gun to the nipple on each front suspension outer fulcrum pin.

### Swivel Axles

Apply the oil gun to the two nipples on each swivel axle. This is best done when the vehicle is partly jacked up, as the oil is then able to penetrate the thrust side of the bearings.

### Shackle Pins

Apply the oil gun to the nipple located on the rear end of each rear spring shackle.

### Brakes

Check the brakes and adjust if necessary (see "Brake Section"). Apply the oil gun to the balance lever on the rear axle, the lubricator on the flexible cable and the pedal pivot nipple.

### Brake and Clutch Fluid Reservoirs

Ascertain that the fluid level in the supply reservoirs, mounted on the steering side of the engine compartment, is up to the indicated level on the outside of each reservoir. Top up if necessary using only the recommended fluid.

### Brakes and Controls

With the oil can, lubricate all the handbrake linkage joints and carburetter control joints.

### Shock Absorbers

Ensure that there are no visible signs of leakage and that the rubber bushes are undamaged.

### Carburetters

Remove the suction chamber cap and damper assembly and replenish oil reservoir as necessary.

### Battery

Ascertain the state of charge of the battery by taking hydrometer readings.

Check that the electrolyte in the cells is level with the tops of the separators. If necessary add a few drops of distilled water. Never use tap water as it contains impurities detrimental to the battery.

Never leave the battery in a discharged condition. If the vehicle is to be out of use for any length of time, have the battery removed and charged once a fortnight.

### Wheels and Tyres

Tighten the wheel nuts and check the tyre pressures, including the spare, using a tyre gauge. Inflate if necessary and see that all valves are fitted with valve caps. Inspect the tyres for injury and remove any flints or nails from the treads. Ensure that there is no oil or grease on the tyres, since these substances are harmful to rubber. See section in "General Data" for correct tyre pressures.

## EVERY 3,000 MILES

(5000 km.)

### Engine

Drain the sump and refill with new oil. Capacity 11 pints (6.25 litres).

### Bonnet Catch

Lubricate with an oil-can the bonnet catch and safety device, and adjust if necessary.

### Fan Belt

The fan belt must be sufficiently tight to prevent slip at the generator and water pump, yet it should be possible to move it laterally about half an inch each way.

To make any necessary adjustment, slacken the bolts and raise or lower the generator until desired tension of the belt is obtained. Then securely lock the generator in position again.

### Fuel Pump

The gauze filter of the fuel pump must be removed and cleaned. The filter plug is situated on the underside of the pump head, and must be unscrewed when the gauze strainer and washer will come away with the plug.

## REGULAR ATTENTIONS

Swill the gauze in petrol and lightly blow through with dry air. On replacing the plug and filter ensure that the washer is in good condition.

### Distributor Automatic Advance

Remove the distributor cap and add a few drops of engine oil through the hole in the contact breaker base through which the cam passes.

### Distributor Cam and Drive-shaft Bearings

Lubricate the distributor camshaft bearings by withdrawing the rotor arm from the top of the distributor spindle and carefully adding a few drops of thin machine oil round the screw exposed to view. Take care to refit the rotor arm correctly by pushing it on to the shaft and turning until the key is properly located.

### Distributor Cam

Apply a trace of engine oil to the distributor cam. Be careful not to let any oil reach the contact breaker points.

### Distributor Shaft

Give the lubricator on the side of the distributor body one full turn in a clockwise direction, to lubricate the distributor drive shaft.

### Contact Breaker Points

Clean the contact breaker points. Cleaning of the contacts is made easier if the contact breaker lever carrying the moving contact is removed. To do this slacken the nut on the terminal post and lift off the spring, which is slotted to facilitate removal. Before replacing, smear the pivot, on which the contact breaker works, with clean engine oil.

Check the contact breaker setting and reset if necessary. The correct gap is .014 to .016 in.

### Sparking Plugs

Remove the plugs and clean off all carbon deposits from the electrodes, insulators and plug threads with a stiff brush dipped in paraffin. Alternatively the plugs may be taken to the local Austin Dealer for cleaning with specialised equipment.

Clean and dress the plug points and reset to the correct gap of 0.025 in.

Before replacing the plugs check that the copper washers are in a sound condition. Never overtighten a plug but ensure that a good joint is made between the plug body, the copper washer, and the cylinder head.

### Wheels

Change over the wheels diagonally (including spare wheel) in order to obtain maximum service with even wear from each tyre.

## EVERY 6,000 MILES

(10000 km.)

### Gearbox

Drain when the oil is warm, i.e., after a run, and refill to the level of the filler plug with new oil. Capacity 5½ Imp. pints (6.3 U.S. pints, 2.98 litres). Also see "Overdrive".

### Overdrive (when fitted)

This oil change is carried out in conjunction with the gearbox attention as the unit has no separate filler plug. However, when draining the gearbox the overdrive drain plug must also be withdrawn.

Remove the overdrive oil pump filter and clean the gauze by washing in petrol. The filter is accessible through the drain plug hole and is secured by a central set bolt.

### Engine Oil Filter

At the same time that the engine oil is changed, drain the full flow filter and renew filter element, not forgetting to top up the filter container with new oil before refitting the head casting on the engine crankcase.

### Shock Absorbers

Check the fluid level, and top up if necessary. The correct level is just below the filler plug threads (see chart for recommended fluid). Carefully clear away all road dirt and grit from the vicinity of the filler plugs before removal.

*N.B.*—Where the recommended fluid is not available the following are acceptable alternatives:—

Shell Donax A.2, Wakefields Castrolite, Mobil-oil Arctic, Esso Hydraulic (Medium), Duckham's N.P. 20, B.P. Energol S.A.E.20.

### Track Alignment

Check front wheel alignment,  $\frac{1}{16}$  in. to  $\frac{1}{8}$  in. toe-in taken along a horizontal line at centre height using the wheel rims as date points.

### Ignition Timing

Check the setting and adjust if necessary.

### Rear Axle

Drain when the oil is warm after a run, and refill to level of the filler plug with new oil. Capacity 3 pints (3.6 U.S. pints, 1.7 litres).

### Front Road Wheel Hubs (Disc Wheels)

Remove the wheel, lever out the hub cap with a screwdriver, and recharge with grease. It is important that the hubs are not overgreased, due to the fact that any surplus may find its way on to the brake linings, thus reducing their efficiency.

## REGULAR ATTENTIONS

---

### Front Road Wheel Hubs (wire wheels)

Unscrew the knock-on hub cap and, using the extractor provided, withdraw the grease cap from within the hubs. Replace with grease, if necessary, but do not over lubricate as excess grease may penetrate to the brake linings.

The splines and cone faces of both hubs and wheels, also the threads of the hub caps, should be smeared with grease.

### Rear Road Wheel Hubs

These are packed with grease upon assembly and do not require greasing attention other than for wheels, splines and cones as detailed for front wheel hubs when wire wheels are fitted.

### Valves

Check valve clearances and adjust if necessary (see "General Data").

### Carburettors

The flow of fuel at each carburetter inlet to each float chamber should be checked and if necessary the filters in the unions should be cleaned.

Remove the bowl of the carburetter for cleaning by disconnecting the fuel supply pipe and slackening the lid retaining nut. Unscrew the chamber support bolt, being careful to note the positions of the brass and fibre washers, and then take off the lid. Do not loose the float needle.

In addition, clean out each suction chamber assembly by removing the three securing screws and lifting off the body in the same plane to avoid damage to the needle.

Lift out the hydraulic damper and wash the assembly in petrol. Dry thoroughly, refit and replenish the damper with oil. When fully reassembled lift the piston to its fullest extent thus expelling surplus oil which lubricates the piston rod and eventually finds its way into the induction pipe.

This is the only part which required lubrication, the piston itself and the inside of the suction chamber should be left dry.

### Water Pump

There is a plug on the water pump housing which should be removed and a small charge of oil injected. It is better to under lubricate than to overdo the attention.

### Generator Bearing

Apply a few drops of S.A.E. 30 engine oil to the commutator and generator bearing via the oil hole provided in the bearing housing.

### Air Cleaners

Every 6,000 miles the air cleaners should be removed, cleaned and re-oiled. Swill each cleaner in petrol, drain, immerse in engine oil and again drain before refitting.

### General Check

Examine and, if necessary, tighten all bolts and nuts such as road spring clips, shock absorber retaining bolts and body panel bolts.

Examine other parts such as steering connections, brake rods, tubing, fuel pipe unions etc., neglect of any of these points may be followed by an expensive repair and inability to use the vehicle for a lengthy period.

### EVERY 12,000 MILES (20000 km.)

### Sparking Plugs

Renew the sparking plugs. Use only Champion N.A.8 Long Reach plugs.

### Speedometer and Tachometer Drives

Disconnect the cables at their instrument end and pull the inner members out of the casing. These should be lubricated sparingly by smearing with light grease. It is important that each drive is not over lubricated, otherwise damage will be caused to the instruments should the lubricant find its way into the head.

To re-assemble, thread the cable concerned with a twisting movement into the casing, since this will help the cable to engage easily with its union at the gearbox or engine adaptor. When this engagement is felt the cable can be pushed home so that the square end stands out approximately  $\frac{3}{8}$  in. from the casing. Connect up to the instrument head.

### Cooling System

Flush out the cooling system. Normally this operation is carried out twice annually upon the addition and removal of anti-freeze. In countries where anti-freeze is not required, however, the cooling system should be flushed out every 12,000 miles.

### Oil Sump

Drain the oil, remove the sump, and clean it thoroughly with petrol. Also clean the oil pump strainer gauze. Replace sump and fill with new oil.

### Front and Rear Hub Bearings

Check for signs of wear.

### Generator and Starter Commutators

Clean and check condition and freedom of brushes in their holders.



## REGULAR ATTENTIONS

---

### **Steering Box**

Check for wear. This can be felt if the front wheels can be moved without creating any movement of the steering wheel.

### **Decarbonising, Valve Grinding and Valve Clearance Adjustment**

This attention may not be needed so frequently on vehicles used for long journeys. As a general guide, a falling off in engine power indicates when decarbonising is due.

**EVERY 24,000 MILES**

(40000 km.)

### **General Check**

The vehicle should be subjected to a thorough examination for wear at least every 24,000 miles. Particular attention should be given to the steering gear and connections, front and rear suspensions, brake linkages, shoe linings, flexible hoses, propeller shaft universals and wheel hub bearings.



# SECTION A

## ENGINE

Section No. A.1	General description
Section No. A.2	Visual inspection
Section No. A.3	Adjustments in the vehicle
Section No. A.4	Engine assembly
Section No. A.5	Lubrication
Section No. A.6	Oil filter
Section No. A.7	Sump and gauze strainer
Section No. A.8	Oil pump
Section No. A.9	Release valve
Section No. A.10	Valve rocker shaft
Section No. A.11	Adjusting valve clearance
Section No. A.12	Rocker shaft assembly
Section No. A.13	Push rod removal
Section No. A.14	Rocker arm bushes
Section No. A.15	Tappets
Section No. A.16	Renewing valve spring in position
Section No. A.17	Manifold
Section No. A.18	Cylinder head
Section No. A.19	Removing and refitting valves
Section No. A.20	Valve grinding
Section No. A.21	Valve guides
Section No. A.22	Decarbonising
Section No. A.23	Connecting rods and bearings
Section No. A.24	Pistons, rings and gudgeon pins
Section No. A.25	Timing chain and wheels
Section No. A.26	Automatic chain tensioner
Section No. A.27	Camshaft and bearings
Section No. A.28	Flywheel and engine rear plate
Section No. A.29	Crankshaft and main bearings
Section No. A.30	Cylinder block
Section No. A.31	Fault diagnosis

---



## Section A.1

### GENERAL DESCRIPTION

The engine is a six cylinder unit with the bores cast integral with the crankcase. Adequate cooling under the most arduous operating conditions is ensured by the provision of large area water circulating passages, and full length water jackets.

The detachable cylinder head is of cast iron and carries the overhead push rod operated valve gear.

Forged steel is used for the counter balanced crankshaft which is supported by four large diameter main bearings of the preformed "Thinwall" type. The same type of bearings are used for the connecting rod big end assemblies.

Particular attention has been paid to the design of the lubrication system to ensure that the moving parts of the engine are adequately supplied with oil at all times. The choice of oils is of great importance and those recommended at the end of this manual have been tested under various running conditions and should be used in accordance with the schedule of regular attentions.

## Section A.2

### VISUAL INSPECTION

Examine the engine for any signs of oil leakage, with particular attention to the sump drain plug, the joint between the oil filter bowl and its head casting, and the rocker cover to cylinder head joint.

The connections to the distributor should be checked occasionally for tightness, and any perished or cracked high tension leads renewed.

## Section A.3

### ADJUSTMENTS IN THE VEHICLE

The purpose of the following adjustments is to maintain the performance of the engine at its maximum, and consists of a series of cleaning, inspecting and adjusting operations. A compression test of each cylinder should first be made to determine the general condition of the engine before proceeding with any adjustments. If a compression gauge is not available, a simple method to test the compression is to remove all the sparking plugs with the exception of the one in the cylinder being tested, and then rotate the engine with the starting handle through at least two complete revolutions. If the cylinder compression is satisfactory, proceed as detailed below, otherwise the specific fault should be diagnosed by referring to "Fault Diagnosis", Section A.31.

- (1) Clean the engine generally and lubricate as indicated on the lubrication chart.

- (2) Adjust the fan belt tension in accordance with the instructions given in Section C.
- (3) Remove the valve gear cover and test the cylinder head studs for tightness, using a torque spanner set to the figures quoted under "General Data".
- (4) Check and adjust the valve and rocker clearances as outlined in Section A.11.
- (5) Check for evidence of cracked valve springs or scored or worn stems.
- (6) Replace the valve gear cover, using a new gasket if necessary.
- (7) Disconnect the high-tension cables and remove the sparking plugs.
- (8) Check to make sure that the correct type of sparking plug is being used.
- (9) Clean the sparking plugs and examine the insulation for breaks or cracks.
- (10) Adjust the sparking plug gaps as specified in Section B.
- (11) Test the sparking plugs and renew any found to be unfit for further service.
- (12) Refit the sparking plugs, using new copper washers.
- (13) Check the high tension cables for wear and deterioration before refitting.
- (14) Remove the distributor head cover and clean it inside and out. Examine it for cracks and burned contacts and renew it if necessary.
- (15) Inspect the contact breaker points to determine whether new points are needed. Follow the procedure given in Section B to clean and adjust the points.
- (16) Check the distributor rotor arm, making sure the carbon brush makes contact. Check the capacitor terminal to make sure it is clean and tight.
- (17) Check the ignition timing as outlined in Section B.
- (18) Clean the air cleaners in accordance with the instructions in Section D.
- (19) Make sure the fuel system is operating properly and clean all filters in the system as detailed in Section D.
- (20) Check the carburetter manifold flange gasket for evidence of leakage.
- (21) Adjust the carburetters if necessary, in accordance with the procedure given in Section D.

## Section A.4

### ENGINE ASSEMBLY

#### To remove (without gearbox)

- (1) Remove the radiator as described in Section C and detach the fan by unscrewing the four securing setpins.

# A

## THE ENGINE

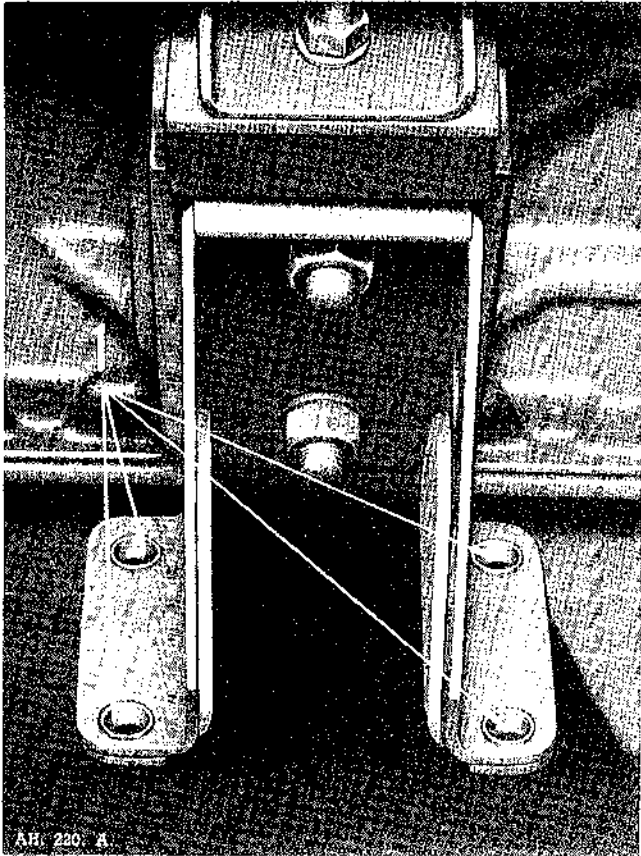

Fig. A.1. The engine left-hand front mounting bracket showing the four setpin holes at 1.

- (12) Release the oil pressure flexible pipe at its upper connection.
- (13) Remove the starter motor as described in Section N.
- (14) Withdraw the four setpins which secure each engine mounting bracket to the chassis frame. Detachment of the left-hand bracket is facilitated by a slit in the carburettor heat shield.
- (15) Unscrew the six brass nuts securing the exhaust down pipe to the exhaust manifolds, and pull the down pipe away from the manifold studs.
- (16) Remove the valve rocker as described in Section A.11 and secure two suitable lifting brackets.
- (17) By means of lifting tackle, similar to that illustrated in fig. A.2, support the engine so that the engine mounting brackets are just clear of their chassis mountings.
- (18) Unscrew the four setpins securing the right-hand engine mounting bracket to the cylinder block and withdraw the mounting.
- (19) Place a suitable support underneath the gearbox bell housing and unscrew the nuts, bolts and setpins securing the bell housing to the engine backplate.

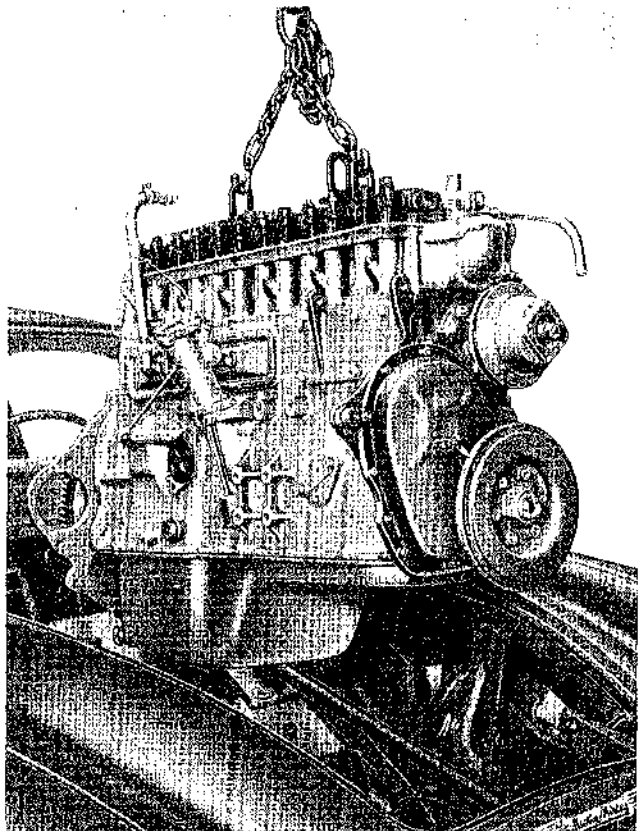

Fig. A.2. Showing the engine being removed at the correct lifting angle.

- (2) Disconnect the throttle linkage and choke control cable. The throttle linkage is freed by unclamping the throttle control rod at its projection from the bulkhead.
- (3) Unscrew the four setpins securing the air cleaners to the carburettor inlets and remove the air cleaners.
- (4) Disconnect the petrol feed pipe at its carburettor union.
- (5) The battery master switch, which is situated inside the luggage compartment, should be turned to the "off" position.
- (6) Remove the high tension cables from their connections at the coil and the sparking plugs.
- (7) Release the generator, distributor and coil low tension cables, and place the complete harness to one side.
- (8) Release the heater inlet and outlet rubber hoses from their connections at the rear of the cylinder head and the heater outlet pipe.
- (9) Remove the distributor as described in Section B.
- (10) Remove the generator, complete with coil, as described in Section N.
- (11) Remove the external oil filter as described in Section A.6.

- (20) Hoist the engine to give clearance between the crankshaft damper and the chassis cross member and pull the engine forward so that the clutch driven plate slides off first motion shaft splines when the engine can be lifted through the bonnet opening and clear of the car.

### To Replace

Replacing the engine is the reverse of the procedure "To Remove"

### To Remove (with gearbox)

To avoid possible damage, either to individual components or to the car, removal of the generator, distributor and right-hand mounting bracket is advised.

- (1) Follow the instructions (1) to (10) and (12) to (18) as detailed in the engine removal less gearbox.
- (2) Inside the car remove the seat cushions and release the clips securing the padded arm rest to the central tunnel.

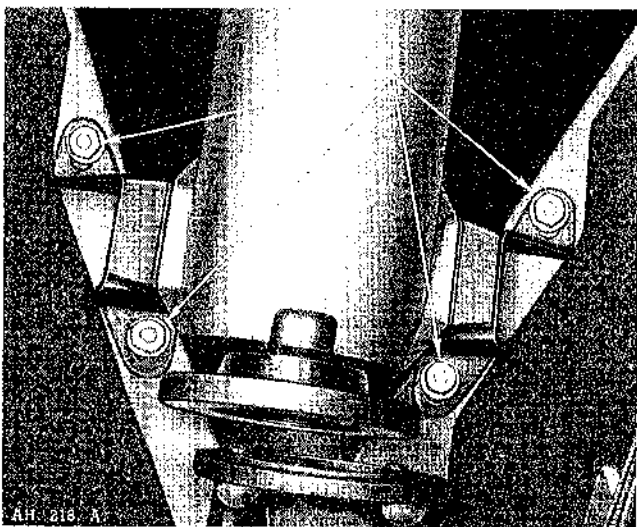

Fig. A.3. The gearbox rear upper securing bracket showing the four setpins at 1.

- (3) Unclip and roll back the carpet over the short gearbox tunnel to expose the twelve screws securing the tunnel to the body of the car. Unscrew the setscrews and remove the tunnel and its carpeting.
- (4) Unscrew the six setscrews, three either side, which secure the carpet covered bulkhead and remove the bulkhead.
- (5) Using a suitable tool tap back the locking washers on the propeller shaft flange bolts and remove the bolts.
- (6) Unscrew the four setpins from the gearbox mounting brackets (see fig. A.3), also unscrew the speedometer cable at its connection to the gearbox.

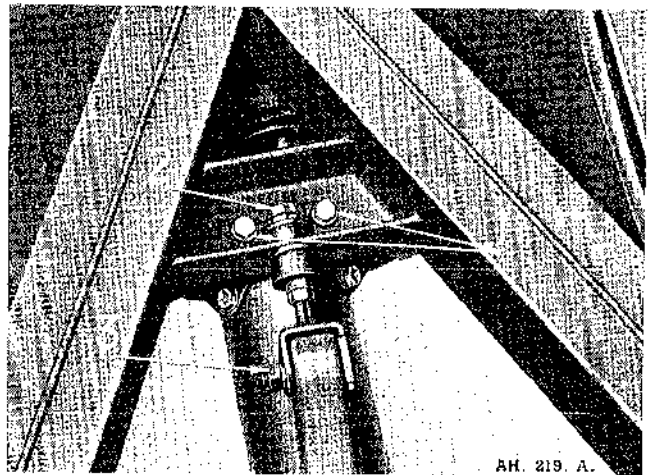

Fig. A.4. The gearbox lower securing points showing 1, Setpins; 2, Stabiliser Adjusting Nut; 3, Securing Pin.

**Note.**—When an overdrive gearbox is fitted it will also be necessary to unclip the cable to the gearbox switch and release it at its terminal on the switch.

- (7) Working beneath the vehicle remove setpins (1) fig. A.4 and unscrew the nuts (2) and (3) to release the stabiliser bar.
- (8) Detach the clutch slave cylinder from the gearbox bell housing by removing the two securing setpins. The slave cylinder push rod is released from the clutch operating lever by the removal of the securing clevis pin.
- (9) Hoist the engine complete with gearbox through the bonnet opening as shown in fig. A.5, ascertain that no damage is done by the gearbox when manoeuvring it through the bulkhead aperture.

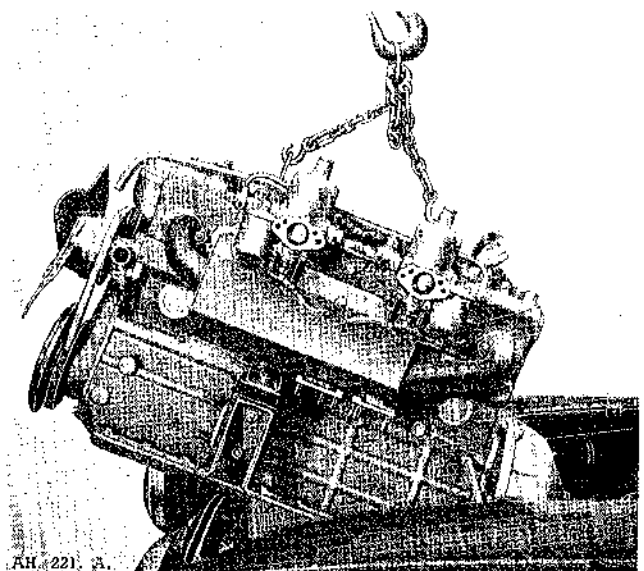

Fig. A.5. Showing the engine and gearbox being removed.

## Section A.5

## LUBRICATION

## Description

The oil supply is carried in the sump below the cylinder block and the filler cap is fitted on the forward end of the rocker cover. The dipstick is on the right-hand side of the engine and is marked to indicate the maximum and minimum levels. The eccentric rotor type oil pump driven by the camshaft is mounted below the crankcase and is partially submerged in the oil reservoir.

Oil is drawn through a gauze strainer secured to the oil pump and passes through a drilling up the right-

hand side of the crankcase to the oil filter, passing the non-adjustable pressure release valve. After leaving the full flow filter the oil-way divides, one drilling passing up the right-hand side of the cylinder block through the cylinder head to a pipe feeding oil to No. 4 rocker shaft bracket. From here, oil passes through the hollow centre of the rocker shaft to lubricate all rocker bearings, and through drillings in the rockers, to lubricate the valve gear. Oil returning to the sump from the rockers lubricates the tappets. The second oil-way from the oil filter passes round No. 3 camshaft bearing, (lubricating this bearing as it does so), to the oil gallery on the left-hand side of the engine. From the gallery, drillings in the cylinder block take oil to each main bearing and through the crankshaft to the big ends. Oil-ways from the main bearings also supply the camshaft bearings. The connecting rods have jet holes to deliver oil to the cylinder walls.

A vent pipe is attached to the rear tappet chamber cover and a breather in the valve rocker cover is connected to the rear air cleaner.

An oil pipe connects the rear end of the main oil gallery on the left-hand side of the engine with the oil gauge on the instrument panel.

## Draining the Sump

The sump on new and reconditioned engines must be drained and filled with new oil after the first 500 miles (800 km.). The oil filter element bowl should be removed at this mileage, the element withdrawn and any sludge cleaned from both these components. The hexagon-headed sump drain plug is at the rear on the right-hand side.

The sump should be allowed to drain for at least ten minutes before the drain plug is replaced. The oil will flow more readily if it is drained while the engine is hot. When the sump has been drained, approximately 11 pints (13.2 U.S. pints, 6.25 litres) of oil are required to fill it. The capacity of the filter is approximately  $1\frac{1}{4}$  pint (1.5 U.S. pints, .84 litres), giving a total of  $12\frac{1}{4}$  pints (14.7 U.S. pints, 7.04 litres). Do not forget to replace the sump drain plug.

Never use petrol or paraffin for flushing purposes. Such cleaning mediums are never completely dispersed from the engine lubrication system, and will remain to contaminate any fresh oil. This may cause premature bearing failure.

At every alternate oil change, or every 6,000 miles (10,000 km.), a new external oil filter element should be fitted.

## Refilling

When refilling the sump do not pour the oil in too quickly, as it may overflow from the filler orifice and

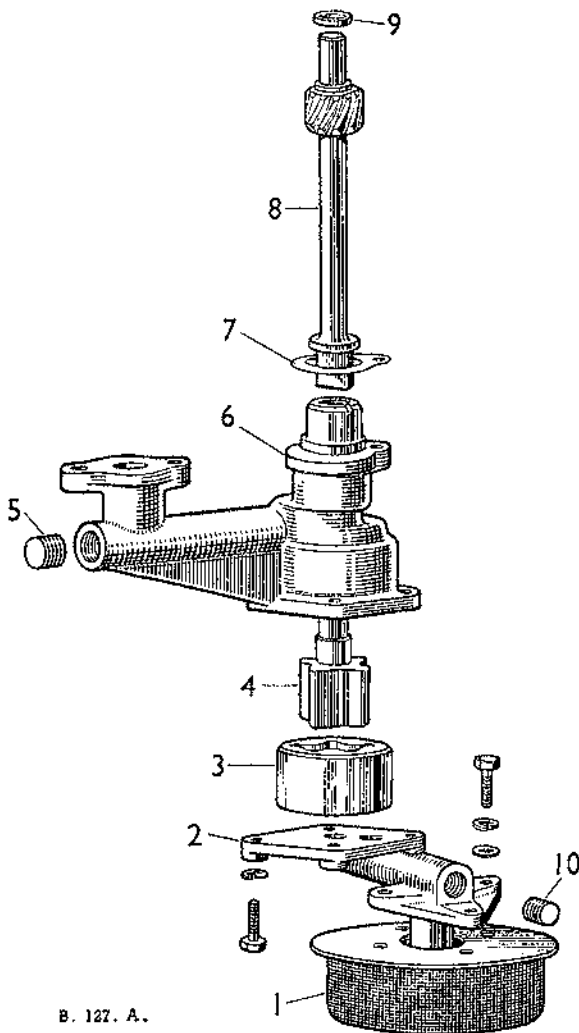

Fig. A.6. Components of the oil pump.

- |                        |                                 |
|------------------------|---------------------------------|
| 1. Pick-up strainer.   | 6. Pump body.                   |
| 2. Bottom lower plate. | 7. Joint washer.                |
| 3. Outer rotor.        | 8. Drive spindle.               |
| 4. Inner rotor.        | 9. Drive spindle thrust washer. |
| 5. Screw plug.         | 10. Screw plug.                 |



THE ENGINE

A

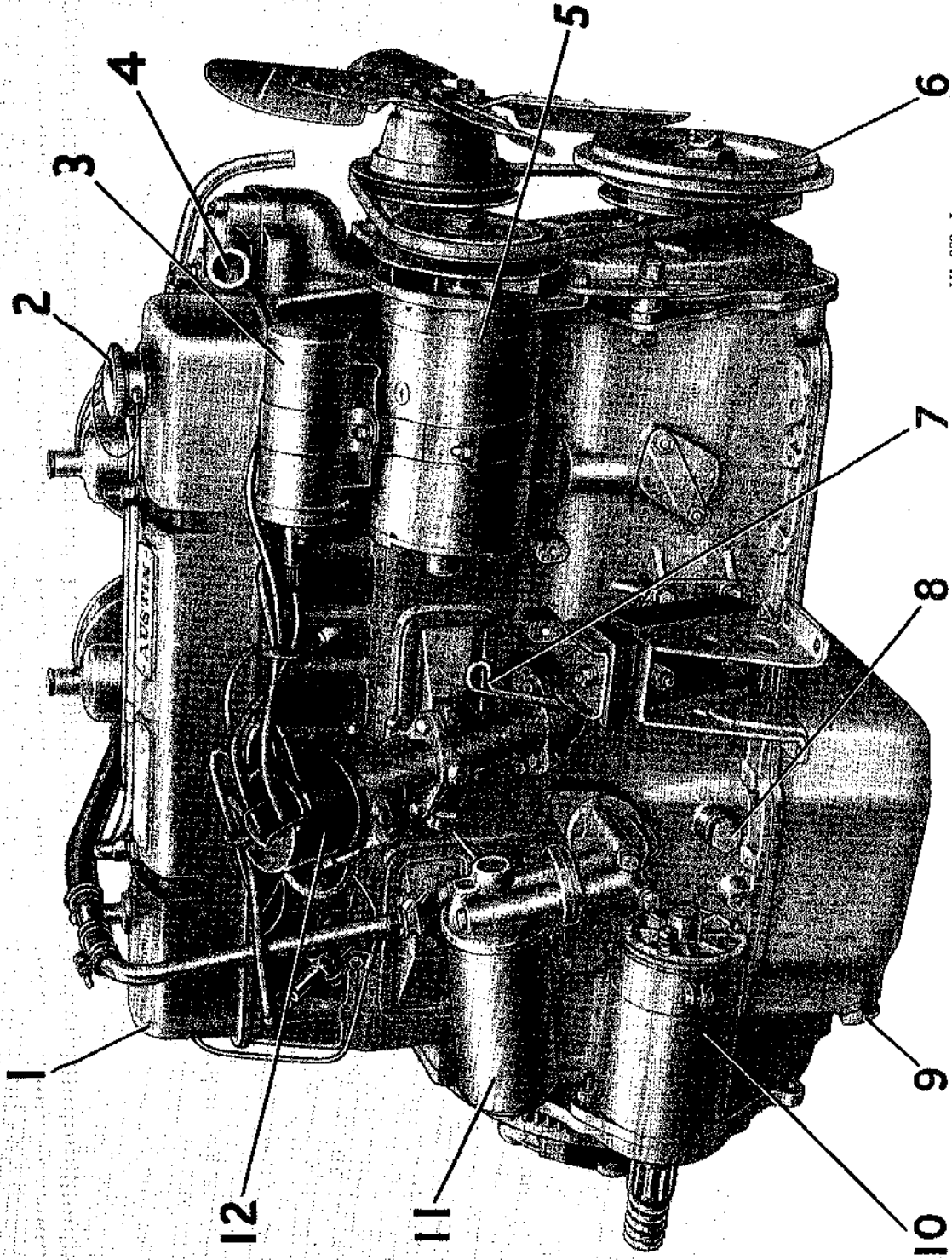

AH. 228. A.

Fig. A.7. Right-hand view of engine.

1. Valve rocker cover.	4. Thermostat cover and coolant outlet.	7. Oil level dipstick.	10. Starter motor.
2. Oil filler cap.	5. Generator.	8. Oil release valve.	11. Oil filter.
3. Ignition coil.	6. Crankshaft stabilizer.	9. Oil sump drain plug.	12. Distributor cap.

mislead the operator as to the quantity of lubricant in the engine.

Before testing the level of the oil, ensure that the vehicle is as near level as possible. Always wipe the dipstick clean with a non-fluffy cloth before taking the reading. It should be remembered that time must be allowed for new oil to reach the sump before reading the dipstick. The dipstick location is shown in fig. A7.

### Oil Pressure

The pressure indicated by the gauge may rise to 60 lbs. per sq. in. when the engine is started up from cold, but after the oil has circulated and become warm, the pressure will drop to approximately 55 lbs. per sq. in., with a proportionately lower idling pressure, (about 25 lbs. per sq. inch). **If no oil pressure is registered by the gauge, stop the engine at once and investigate the cause.**

**Note:** The automatic release valve in the lubrication system deals with any excessive oil pressure when starting from cold.

Continuous running with unnecessary use of the mixture control is often the cause of serious oil dilution by petrol, and a consequent drop in pressure.

### Check for Low Oil Pressure

Check the level of oil in the engine sump by means of the dipstick and top up if necessary. Ascertain that the gauze strainer in the sump is clean and not choked with sludge, also that there is no air leakage at the strainer union on the suction side of the pump.

In the unlikely event of the oil pump being defective, remove the unit and rectify the fault, see Section A.8. The oil release valve should be examined, see Section A.9.

If the engine bearings are worn the oil pressure will be reduced. A complete bearing overhaul and the fitting of replacement parts is the only remedy, necessitating the removal of the engine from the chassis.

## Section A.6

### OIL FILTER

The external filter is a full flow type thus ensuring that all oil in the lubrication system passes through the filter before reaching the bearings.

The element of the filter is of star formation in which a special quality felt, selected for its filtering properties, is used.

Oil is passed to the filter from the pump at a pressure controlled at 50/55 lbs. per sq. inch by the engine oil release valve. Some pressure is lost in passing the oil through the filter element; this will only be a pound or two per square inch with a new element, but will increase as the element becomes progressively contaminated by foreign matter removed from the oil.

Should the filter become completely choked due to neglect, a balance valve is provided to ensure that oil will still reach the bearings. This valve, set to open at a pressure difference of 15/20 lbs. per square inch, is non-adjustable and is located in the filter head casting. When the valve is opened, unfiltered oil can by-pass the filter element and reach the bearings.

To renew the filter element proceed as follows :—

- (1) Unscrew and remove the tachometer drive from the distributor housing.
- (2) Remove the two setpins securing the filter bracket to the crankcase.
- (3) Unscrew the centre fixing bolt, and the container complete with element can be removed.
- (4) Withdraw the contaminated element and carefully cleanse the container of all foreign matter that has been trapped.
- (5) After ensuring that no fibres from the cleansing operation have been left in the container, put in a new element, prime the filter and refit to the head casting, tightening the centre fixing bolt sufficiently to make an oil-tight joint.

Fig. A.8. Engine components.

- |                              |                             |                              |                                |
|------------------------------|-----------------------------|------------------------------|--------------------------------|
| 1. Filter bowl.              | 18. Oil control ring.       | 35. Outer valve spring.      | 52. Oil seal.                  |
| 2. Element.                  | 19. Piston.                 | 36. Spring cap.              | 53. Tachometer gear.           |
| 3. Head casting.             | 20. Oil pump drive spindle. | 37. Oil seal.                | 54. Securing pin.              |
| 4. Filter extension bracket. | 21. Oil pump body.          | 38. Collars.                 | 55. Distributor drive.         |
| 5. Split pin.                | 22. Inner rotor.            | 39. Split pin.               | 56. First motion shaft bush.   |
| 6. Plain washer.             | 23. Outer rotor.            | 40. Bush.                    | 57. Drain pipe.                |
| 7. Spring washer.            | 24. Bottom cover.           | 41. Oil seal.                | 58. Release valve assembly.    |
| 8. Rocker bush.              | 25. Pick-up stainer.        | 42. Spindle housing.         | 59. Big end cap.               |
| 9. Rocker adjusting screw.   | 26. Shell bearing big end.  | 43. Washer.                  | 60. Thrust washer.             |
| 10. Rocker.                  | 27. Connecting rod.         | 44. Tachometer spindle.      | 61. Centre front main bearing. |
| 11. Spacing washer.          | 28. Tappet.                 | 45. Rocker shaft.            | 62. Crankshaft gear.           |
| 12. Rocker shaft bracket.    | 29. Camshaft bearings.      | 46. Rocker shaft plug.       | 63. Oil thrower.               |
| 13. Spacing spring.          | 30. Exhaust valve.          | 47. Camshaft gear.           | 64. Crankshaft pulley.         |
| 14. Rocker oil feed pipe.    | 31. Exhaust valve guide.    | 48. Timing chain.            | 65. Vibration damper.          |
| 15. Push rod.                | 32. Inlet valve.            | 49. Camshaft location plate. | 66. Starter dog.               |
| 16. Gudgeon pin.             | 33. Inlet valve guide.      | 50. Camshaft.                | 67. Timing chain tensioner.    |
| 17. Compression rings.       | 34. Inner valve spring.     | 51. Plug.                    |                                |

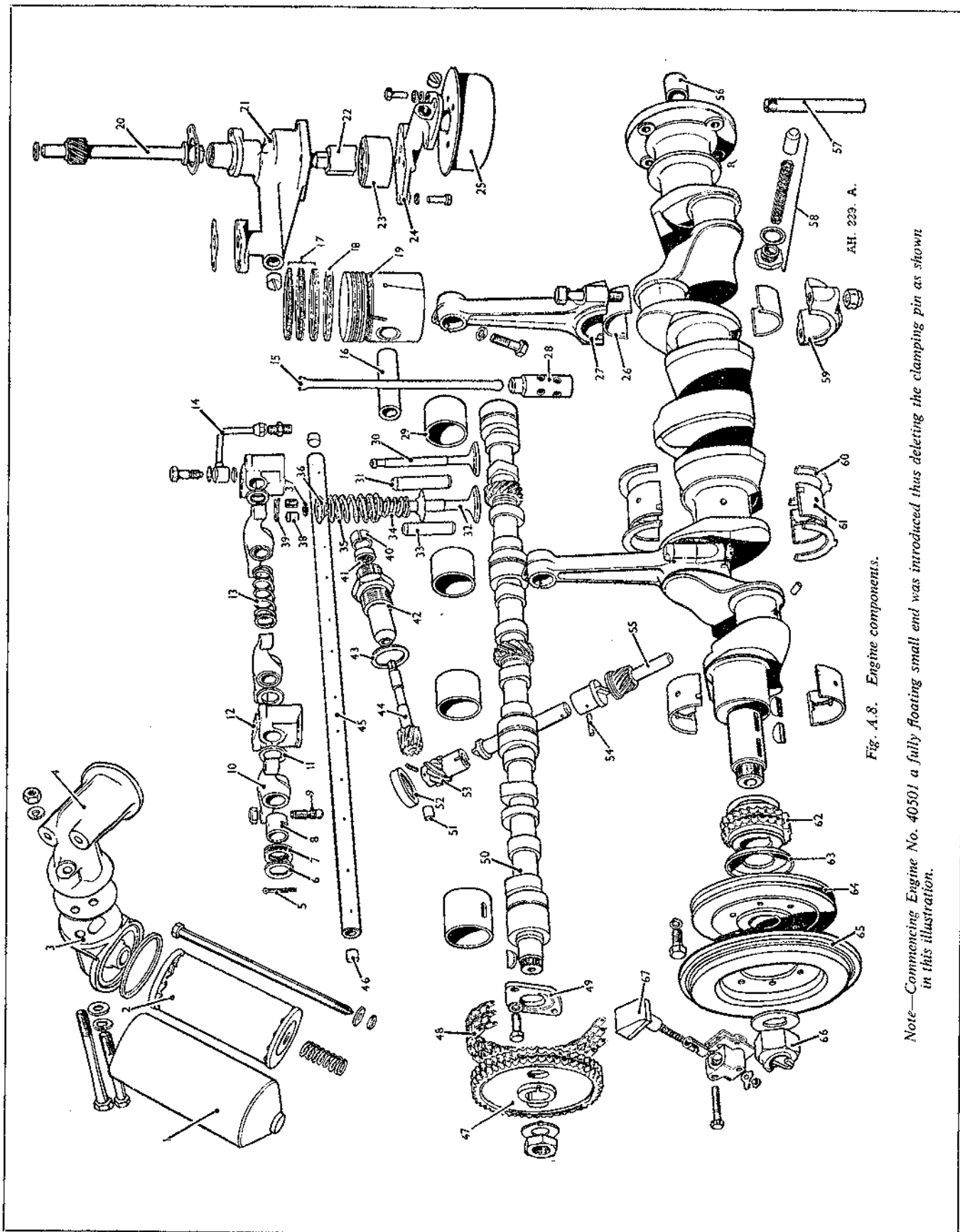

AH. 229. A.

Fig. A.8. Engine components.

Note—Commencing Engine No. 40501 a fully floating small end was introduced thus deleting the clamping pin as shown in this illustration.

- (6) Replace the filter and bracket complete by means of the two setpins.
- (7) Refit the tachometer drive to the distributor housing.
- (8) Check the level of oil in the sump by means of the dipstick.

It is recommended that the filter container should not be disturbed other than for the fitting of a new element; to do so invites the hazard of added contamination from accumulated dirt on the outside of the filter entering the container, and thus being carried into the bearings on restarting the engine.

## Section A.7

### SUMP AND GAUZE STRAINER

#### Removing

- (1) Drain off the oil into a suitable container then extract the setscrews and washers, thus enabling the sump to be removed.
- (2) Detach the bottom of the strainer by removing the nut, washer and distance piece. Take out the three setpins holding the strainer to the pump, so allowing the body of the gauze strainer to be removed. The pump and strainer can be swilled out with petrol or paraffin and thoroughly dried with a non-fluffy rag.
- (3) Inspect the two joint washers and renew if they are damaged in any way.

#### Refitting the Sump

Clean out the sump by washing it in paraffin. Take care to remove any traces of the paraffin before refitting the sump to the engine. Pay particular attention to the sump and crankcase joint faces, and remove any traces of old jointing material. Examine the joint washer and renew it if necessary. The old joint washer can be used again if it is sound, but it is advisable to fit a new one.

Smear the faces of the joint with grease and fit the joint washer. Lift the sump into position and insert the setscrews into the flange tightening them up evenly.

## Section A.8

### OIL PUMP

#### Removing the Oil Pump

- (1) Remove the sump and pick up strainer.
- (2) Take off the nuts and spring washers from the three studs which secure the oil pump assembly to the crankcase, when the pump can be withdrawn.

If the pump is removed with the engine still in the car, the drive shaft will be free to disengage from the camshaft, and care must be taken to

prevent it falling out. Note also the thrust washer fitted on the drive shaft above the gear.

#### Dismantling the Oil Pump

Mark the flange and pump body to assist reassembly. Separate the body from the bottom flange. The outer rotor can then be lifted out of the body.

#### Replacing the Oil Pump

Insert the pump from below and push the shaft right home until the driving gear is meshed with the gear on the camshaft.

## Section A.9

### RELEASE VALVE

The non-adjustable oil pressure relief valve is situated at the rear of the right-hand side of the cylinder block below the oil filter and is held in position by a hexagon nut sealed by a copper washer. The relief valve spring retains a valve cup against a seating machined in the block.

## Section A.10

### VALVE ROCKER SHAFT

The valve rocker shaft on the cylinder head is hollow. It is supplied with oil by a pipe connection and is drilled for lubrication to each rocker bearing.

This shaft is plugged at each end, one of these being screwed in order that the shaft may be cleaned internally.

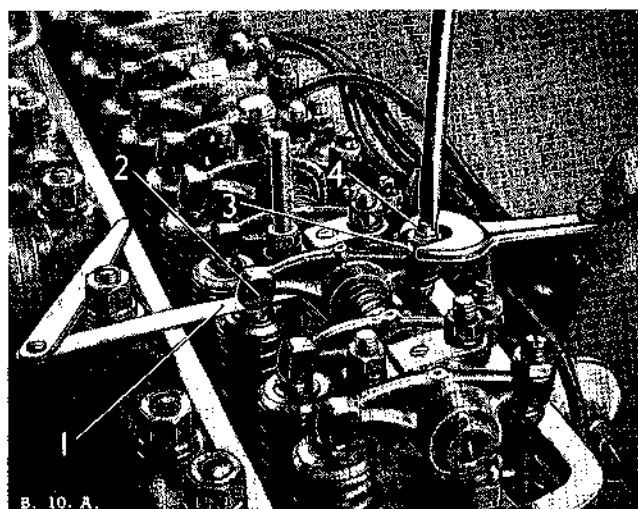

Fig. A.9. Valve adjustment.  
1. Feeler gauge. 2. Rocker. 3. Lock nut.  
4. Adjusting screw.

## Section A.11

### ADJUSTING VALVE CLEARANCE

Lift off the valve cover after removing the two flat and two dome cap nuts.

Between the rocker arm and the valve stem there must be a clearance of .012 in. (.305 mm.) for both inlet and exhaust, clearance being set with the engine hot.

- (1) If adjustment is necessary, slacken the locknut whilst continuously applying sufficient pressure to the adjusting screw with a heavy screwdriver, and raise or lower the adjusting screw in the rocker arm. Check the clearance with a feeler gauge.
- (2) Tighten the locknut when the adjustment is correct, but always check it again afterwards in case the adjustment has been disturbed during the locking process.
- (3) When replacing the valve cover, take care that the joint washer (using a new one if necessary) is properly in place to ensure an oil tight joint.

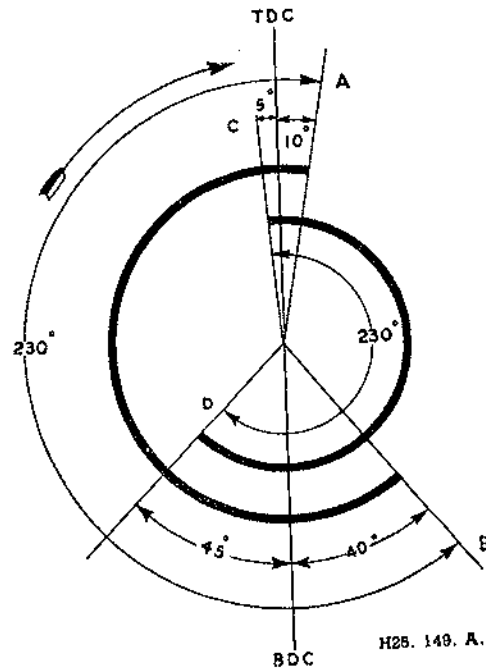

## Section A.12

### ROCKER SHAFT ASSEMBLY

#### Removal

- (1) Disconnect the breather pipes at their rocker cover terminals.
- (2) Unscrew the two flat and two dome nuts securing the rocker cover to the cylinder head, taking care not to damage the cork gasket, and remove the rocker cover.
- (3) Detach the oil feed pipe at the union on the cylinder head.
- (4) Unscrew and remove the twelve nuts and spring washers which hold the rocker shaft brackets to the cylinder head.
- (5) Remove the rocker assembly, complete with brackets, rockers and oil feed pipe.

#### Dismantling

- (1) Unscrew and remove the oil feed pipe banjo from its bracket noting its corresponding position on the shaft.
- (2) Remove the split pins from the end of the rocker shaft to release thrust washers and double coil springs.
- (3) Withdraw rocker, rocker shaft brackets, thrust washers and springs, retaining them in their original order for reassembly.

#### Reassembling

When reassembling the rocker gear, commence with No. 4 bracket and secure the oil feed pipe with the washers in position, ensuring that the dowel on the banjo bolt locates in the rocker shaft.

Fig. A.10. Valve timing diagram.

Exhaust closes at A, and opens at B, inlet opens at C and closes at D.

The brackets are fitted with the highest lug to the camshaft side of the engine, and the rocker shaft is fitted with the screwed in end plug to the front. The rear end tapered plug is a drive fit.

A thrust washer is fitted each side of each rocker shaft bracket, and all springs, and rockers, and the remaining brackets are interchangeable.

## Section A.13

### PUSH ROD REMOVAL

If the valve rocker assembly has already been removed all that remains is for the push rods to be lifted out. They may on the other hand be taken out without detaching the rocker assembly as described below :—

- (1) Remove the valve rocker cover as described in Section A.12 and slacken the valve adjustment screw to its full extent.
- (2) With the aid of a screwdriver supported under the rocker shaft, depress the valve and slide the rocker sideways free of the push rod.
- (3) Withdraw the push rod.
- (4) In the case of the rocker at each end, it is necessary to take out the split pins at the end of the shaft.
- (5) The above sequence should be reversed when replacing push rods and rockers.

## Section A.14

### ROCKER ARM BUSHES

- (1) While the rocker gear is detached from the head, check for play between the rocker shaft and the rocker arm bushes. If this is excessive new bushes should be fitted. To do this dismantle the rocker assembly as described in Section A.12.
- (2) The bush is best removed by using a drift and anvil (Service Tool No. 18G 21). The anvil is recessed to retain the rocker in position while the bush is gently knocked out by the drift. File and drill out the rivet in the rocker arm oilway.
- (3) The flange of the drift is also recessed to prevent the new split bush from opening when being driven into position with the joint immediately above the rocker arm oilway.
- (4) Drill an oilway through the bush from the top of the rocker using a .0785 in. diameter drill. A second oilway must be drilled through the bush via the rocker arm using a .089 in. diameter drill.
- (5) Plug the oilway in the rocker arm with a rivet and weld its head to the rocker boss. Reamer the internal diameter of the bush to suit the shaft.

## Section A.15

### TAPPETS

#### Removal

- (1) Remove the valve rocker shaft assembly as detailed in Section A.12.
- (2) Disconnect the dynamo terminals and remove the set bolt securing the dynamo to the slotted link. Take out the bolts on which the dynamo pivots and remove the dynamo and coil.

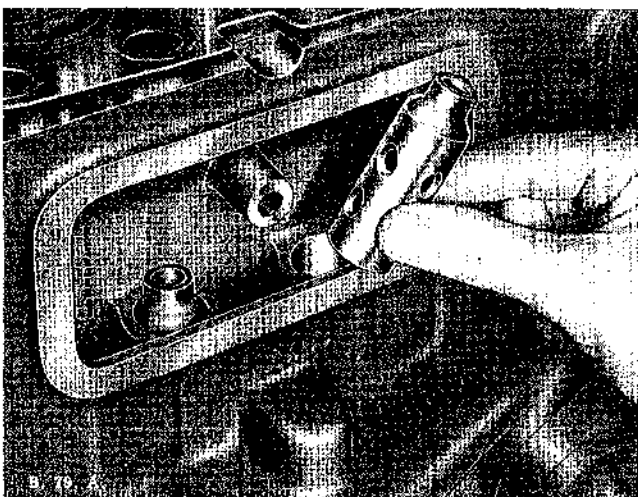

Fig. A.11. Removing a tappet.

- (3) Release the front tappet chamber cover by removing the five securing bolts. The centre and rear tappet chamber covers give access to the valves for No. 3, 4, 5 and 6 cylinders when the single retaining bolts are removed.
- (4) Withdraw the push rods, keeping them in their respective positions to ensure replacement onto the same tappets. Lift out the tappets, keeping them in the same respective locations. Inspect the tappet cam contacting surfaces for wear. New tappets should be fitted by selective assembly so that they just fall into their guides under their own weight when lubricated.

#### Replacement

Assembly is a reversal of the above procedure, but care should be taken to see that the tappet cover joints are oil-tight and that the rockers are adjusted to give the correct valve clearance.

## Section A.16

### RENEWING VALVE SPRING IN POSITION

- (1) In an emergency a new valve spring(s) can be fitted without lifting the cylinder head, but it is advisable first to bring the piston to top dead centre, to ensure that the valve cannot fall into the cylinder during the process.
- (2) Remove the sparking plug, and by means of a length of copper tubing or similar tool inserted through the plug hole, the valve can be held on its seat whilst the spring is compressed. The valve rocker shaft can be used as a fulcrum point by an operator using two screwdrivers to bear on the valve spring cap each side of the valve stem, whilst the cotters are removed.

## Section A.17

### MANIFOLD

#### Removal and Replacement

- (1) Detach the air cleaners from the carburettors by unscrewing the four setpins and releasing the breather pipe attached to the air cleaner.
- (2) Disconnect the heat shield by removing the two securing nuts and washers.
- (3) Unscrew and remove the six brass nuts and plain washers which secure the exhaust manifold to the down pipes.
- (4) Disconnect the throttle and choke linkages to the carburettors, together with the vacuum control pipe and petrol feed pipe.
- (5) Unscrew and remove the 14 nuts and washers which secure the exhaust manifold and carburettors to the cylinder head (four on the

carburettor flanges, ten on the exhaust manifold). This will automatically release the heater outlet pipe.

- (6) The exhaust manifold and carburettors can then be drawn off their respective studs and lifted clear of the engine.
- (7) Reassembly is the reverse of the above procedure; always use a new joint washer for the exhaust manifold to ensure an air tight joint.

- (5) Replace the rocker gear and connect the oil feed pipe, as described in Section A.12.
- (6) Reset the valve clearance, and replace the rocker cover using a new joint washer if the old one is damaged in any way.

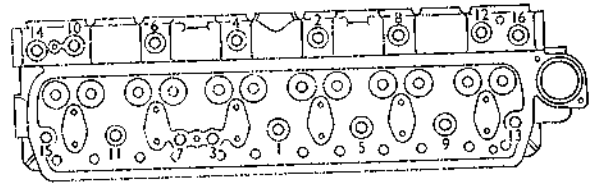

B. 40. A.

*Fig. A.12. The order of tightening for the cylinder head nuts.*

## Section A.18

### CYLINDER HEAD

#### Removing

- (1) Drain all water from the cooling system, if the water contains anti-freeze mixture, it should be run into a clean container and used again.
- (2) Detach the top water hose from the cylinder head.
- (3) Disconnect the high tension wires from the sparking plugs and remove the plugs.
- (4) Detach the exhaust manifold, complete with carburettors, as detailed in Section A.17.
- (5) Remove rocker cover and breather pipes as described in Section A.12.
- (6) Release the suction advance pipe clip from its securing point on the cylinder head. Also slacken the retaining clip and detach the heater inlet hose.
- (7) Remove the rocker assembly as described in Section A.12.
- (8) Withdraw the push rods, keeping them in order of removal taking care not to pull the tappets out of their guides in the block.
- (9) Remove the sixteen cylinder head nuts together with their flat washers and lift off the cylinder head.

#### Replacing

- (1) Replace the cylinder head joint washer with the side marked "Top" uppermost, it is not necessary to use jointing compound or grease for the gasket.
- (2) Having slipped the gasket over the studs, next lower the cylinder head into position and position the cylinder head stud nut washers. Ensure that a bronze washer is fitted below the steel washer on each stud which passes through the inlet manifold on the left-hand side of the head; also ensure that the suction advance pipe clip is replaced in its original position on the cylinder head.
- (3) Fit the studs finger tight and then tighten them a turn at a time, in the order given in fig. A.12, to the recommended torque spanner readings.
- (4) Insert the push rods, ensuring that the ball ends are correctly located in the tappets.

- (7) Replace the exhaust manifold and carburettors and connect up the petrol pipe, throttle and choke controls and heater outlet pipe. Tighten the manifold nuts evenly ensuring that a good joint is made.
- (8) Reconnect heater inlet pipe, water hose from the thermostat housing to the radiator, and breather pipes.
- (9) Refill the cooling system, replace the sparking plugs and their washers, and the high tension wires to their respective plugs.
- (10) Check the valve clearance again after the vehicle has run about 100 miles (160 km.) as the valves have a tendency to bed down. At the same time it is advisable to test the cylinder head nuts for tightness. Tightening the cylinder head nuts may affect valve clearances, although not usually enough to justify resetting.

## Section A.19

### REMOVING AND REFITTING VALVES

With the cylinder head removed, a valve lifting tool can be used to compress the springs (Service Tool No. 18G 106). Take away the circlip, split cotters, and valve stem cap, so releasing the springs and allowing the valve to be removed.

- (1) When removing the valves, place them in a rack, thus enabling them to be paired up with their correct cylinders. The valve springs should be tested and their free length checked, the correct length being approx. 1.969 in. (50.03 mm.) for the inner spring and 2.047 in. (52 mm.) for the outer spring.
- (2) Clean the carbon from the top and bottom of the valve heads, as well as any deposit that may have accumulated on the stems. The valve heads should, if necessary, be refaced at an angle of 45° for the exhaust valve and 30° for the inlet valve. If the valve seats show signs of excessive pitting it is advisable to reface these also.

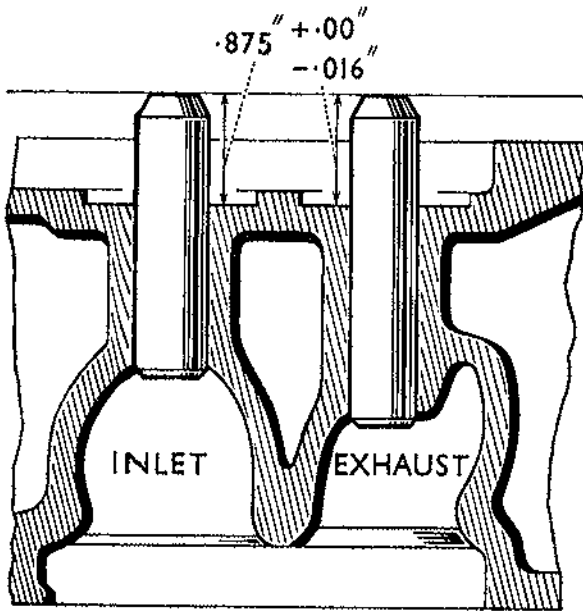

B. 142. A.

Fig. A.13. Showing the position of the valve guides after fitting.

- (3) The valves are made without any indentures or slots in the head, this necessitates the use of a rubber suction valve grinding tool.
- (4) Reassembly is a reversal of the operations for removal.

## Section A.20

### VALVE GRINDING

- (1) For valve grinding a little grinding paste should be smeared evenly on the valve face, and the valve rotated backwards and forwards against its seat (using Service Tool No. 18G 29), advancing it a step at short intervals until a clean and unpitted seating is obtained. The cutting action is facilitated by allowing a light spring situated under the valve head, to periodically lift the valve from its seat. This allows the grinding compound to re-penetrate between the two faces after being squeezed out.
- (2) On completion, all traces of compound must be removed from the valve and seating. It is essential that each valve is ground-in and refitted to its own seating.
- (3) It is also desirable to clean the valve guides; this can be done by dipping the valve stem in petrol or paraffin, and moving it up and down in the guide until it is free.

## Section A.21

### VALVE GUIDES

- (1) The valve guides are of a one-piece design. They

are pressed into the cylinder head to allow .859 to .875 in. (21.8 to 22.23 mm.) of the guide to protrude above the machined face when fitted.

- (2) To position each valve spring on the cylinder head, a stepped pressed steel seating collar is fitted over the part of the guide protruding from the cylinder head.
- (3) Valve guides should be tested for wear whenever valves are removed, and if excessive side play is present, a close check should be made of the valve stem and the guide. In the event of wear being noticeable, the defective components should be renewed. If a valve is at fault the wear will be evident on the stem. It should be borne in mind that the valve stem and guide should be a running fit to avoid the possibility of an air leak.

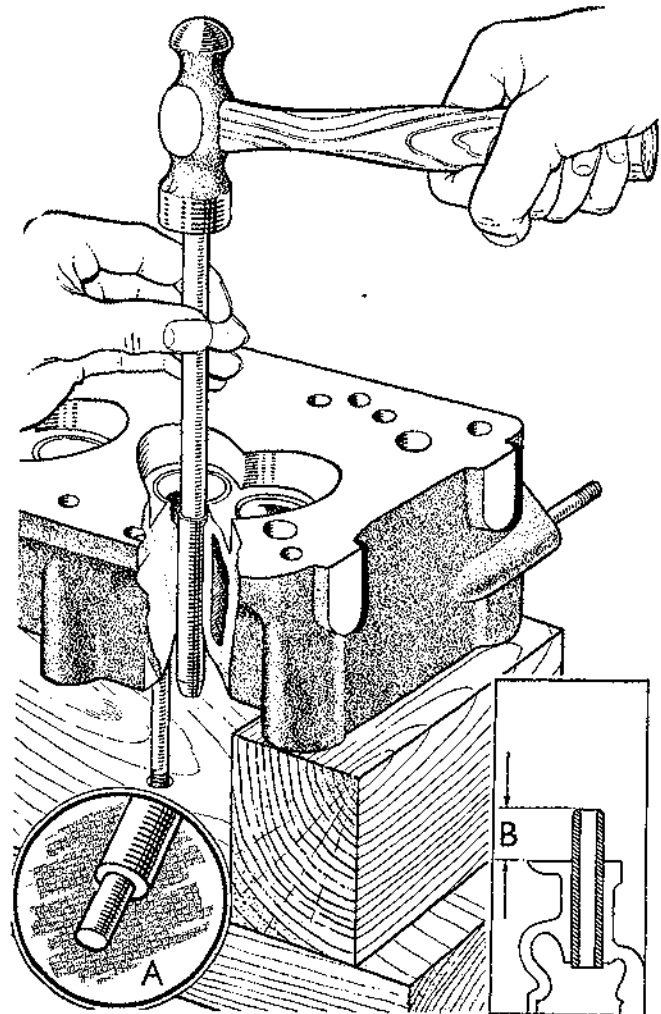

TH. 145. A.

Fig. A.14. Removing a valve guide. A shows the stepped end of the tool. B indicates the portion of the guide which must stand above the surface.



- (4) If renewal is necessary due to wear, the valve guide may be driven out after removal of the valve, as shown in fig. A.14 (using Service Tool No. 18G 228).
- (5) The drift is stepped in order to ensure location and to obviate it slipping off the guide and damaging the port. Knock out the guide in the direction shown.
- (6) A new guide should be driven into position in the same direction, that is, inserting it through the valve seating and driving towards the top of the cylinder head.
- (7) The final position of the guide is shown in fig. A.13.

## Section A.22

### DECARBONISING

- (1) Remove the cylinder head as described in Section A.18.
- (2) Scrape off all carbon deposit from the cylinder head and ports. Clean the carbon from the piston crowns, care being taken not to damage the pistons, and not to allow dirt or carbon deposit to enter the cylinder barrels or push rod compartment.  
When cleaning the top of the pistons do not scrape right to the edge as a little carbon left on the chamfer assists in keeping down oil consumption; with the pistons cleaned right to the edge or new pistons, oil consumption is often slightly though temporarily increased.
- (3) Blow out the oil passages and swill out the water passages using a water hose. The gasket contacting surfaces of the head should be checked for flatness with a straight-edge and the surfaces examined for scores. If the cylinder head is found to be badly out of true it should be renewed.
- (4) Remove all carbon accumulation from the valves and thoroughly clean them. Inspect the valve bases and seats and if they are slightly pitted or rough, grind them in, as described in Section A.20. If the valves and seats show signs of excessive pitting, or the faces are not flat, the valves and seats should be replaced.
- (5) Examine the valve guides, as described in Section A.21.
- (6) Broken or weak valve springs should be renewed. The other valve springs should be tested and the results compared with figures given under "General Data".
- (7) Clean the rocker shaft gear and blow out the oil passages as described in Section A.10.

- (8) Inspect the rocker shaft, rockers and bushes for wear. Renew any worn rocker bushes as described in Section A.14.
- (9) Reassemble and install the cylinder head assembly.

The following operations should be carried out with the engine removed, although in some cases it is possible to perform them with the engine in position.

Before removing or replacing any component it is important to ensure that all surrounding surfaces are perfectly clean, to prevent the entry of foreign matter into the engine. This can best be accomplished by the use of a paraffin bath and brush, and it is also important to note that fluffy rags should never be used, as there is danger of causing obstruction to small oil ways.

## Section A.23

### CONNECTING RODS AND BEARINGS

#### Removal

- (1) Remove the cylinder head assembly as described in Section A.18.
- (2) Drain and remove the sump (see Section A.5).
- (3) Remove the self-locking nuts securing the caps and bearings to the connecting rods. Remove the caps and bearings.
- (4) Withdraw the pistons and connecting rods upwards through the cylinder bores.

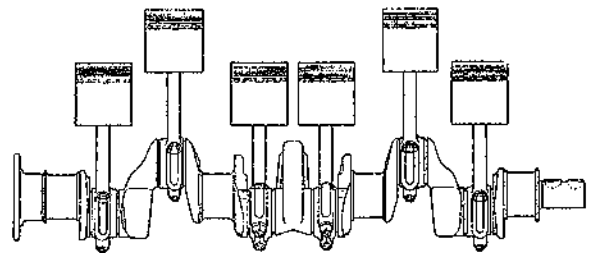

B. 125. A.

*Fig. A.15. Showing the positions of connecting rod off-sets.*

- (5) It may be necessary to remove the carbon or ridge from the top of the bores prior to pushing the pistons upwards, to avoid piston-ring fracture.
- (6) Remove the pistons from the connecting rods by unscrewing the clamp bolt from the small end of the connecting rod and pushing the gudgeon pin out.
- (7) Ensure that each connecting rod, cap and bearing is marked with the cylinder number from which it was removed.
- (8) The big ends are offset, and rods in numbers 1, 3 and 5 cylinders are offset towards the front, with 2, 4 and 6 cylinders offset towards the rear.

- (9) The alignment of the connecting rods should be checked on an alignment fixture. On no account must the rods or caps be filed.
- (10) Examine the bearing shells for wear and pits. Renew the bearing shell if necessary. Bearings are pre-finished with the correct diametrical clearance and do not require bedding in.
- (11) Check the crankpins with a micrometer if they are worn oval or are scored, the crankshaft will have to be removed for regrinding, see Section A.29.

### Replacing

Before installing the connecting rods and bearings it is assumed that the pistons and rings have been serviced, see Section A.24.

The pistons and connecting rods must be fitted in the same cylinder bores and the same way round as when removed.

- (1) Assemble the piston and the connecting rod to the gudgeon pin, so that the split in the piston skirt is adjacent to the split in the top of the connecting rod.

- (2) Refit the piston rings very carefully, make quite sure that the pistons and bores are perfectly clean and smear the bores with clean engine oil.
- (3) Use a piston ring clamp, service tool No. 18G 55, when replacing the pistons from the top of the bore, and make sure that the split in the piston faces away from the camshaft.
- (4) Clean the crankpins and both sides of the shell bearings, locate the feathered ends in the connecting rod and its cap, and smear the crankpins with engine oil.
- (5) Before fitting the cap, check that the number stamped on the rod is the same as that on the cap. Note that the recesses in the cap and rod must be on the same side. Tighten the nuts. Turn the crankshaft after fitting each rod, to ensure that the bearing is not binding on the crankpin. Also check the side clearance of each rod, as given under "General Data".
- (6) Refit the cylinder head assembly, see Section A.18.
- (7) Refit the sump and refill with recommended grade of oil, see Section Q.

## Section A.24

### PISTONS, RINGS AND GUDGEON PINS

#### Removal

The split-skirt pistons are of aluminium alloy material. Four rings are fitted above the gudgeon pin, the bottom ring being of the oil-control type. The pistons are fastened to the connecting rods by gudgeon pins which are clamped rigidly in the small ends of the connecting rods. Bushings are not needed in the gudgeon pin bosses of the pistons because the aluminium alloy material serves as a suitable bearing for the gudgeon pins, the bearing surfaces of which are lubricated by means of splash through the two holes drilled in each boss. To remove the pistons see Section A.23.

#### To view and overhaul

- (1) Remove the rings over the tops of the pistons.
- (2) Scrape all accumulation of carbon off the piston heads and, using a piston ring groove-cleaning tool or an old ring section, carefully scrape all carbon out of the ring grooves of the pistons. Clean the carbon out of the oil holes in the piston ring grooves.
- (3) Thoroughly clean all the dismantled components in paraffin.
- (4) Examine all parts for wear and damage, renew if necessary.
- (5) If cylinder reconditioning is required (see Section A.30), determine the amount of material to be removed (refer to "General Data" concerning oversize pistons available).

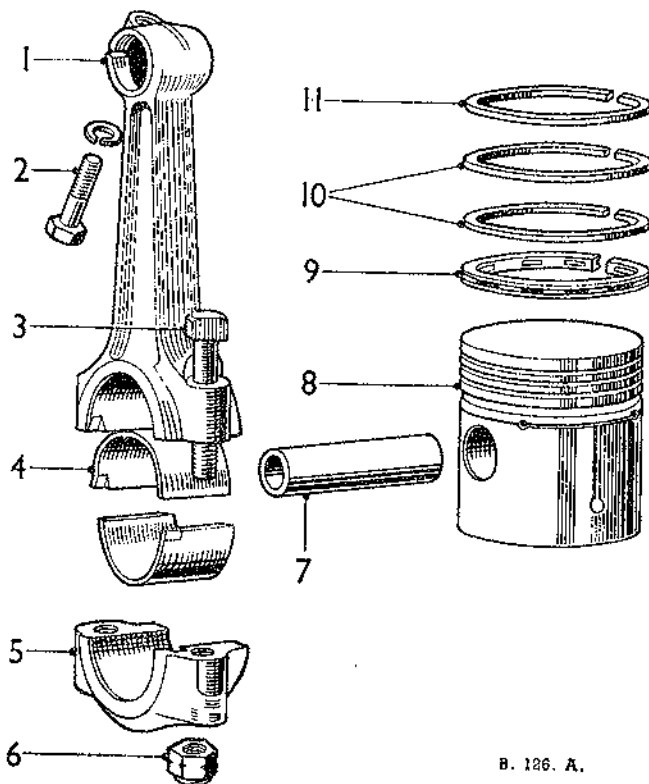
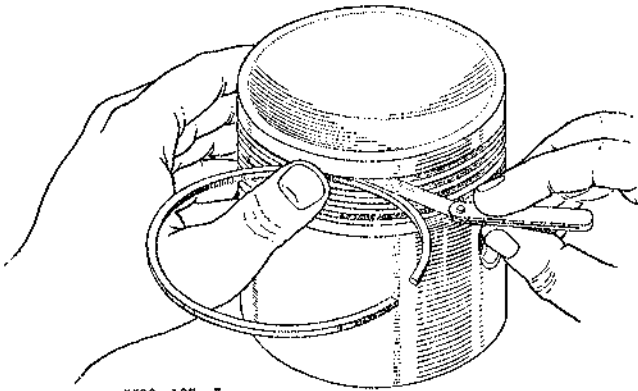

Fig. A.16. Connecting rod and piston assembly.

- |                              |                              |
|------------------------------|------------------------------|
| 1. Connecting rod.           | 7. Gudgeon pin.              |
| 2. Small end clamping screw. | 8. Piston.                   |
| 3. Big end bolt.             | 9. Oil control ring.         |
| 4. Shell bearing.            | 10. Taper compression rings. |
| 5. Big end cap.              | 11. Plain compression ring.  |
| 6. Big end nut.              |                              |



H30. 125. A.  
Fig. A.17. Checking piston ring and groove clearance.

- (6) When fitting new or oversize pistons and rings to reconditioned cylinder bores, the clearances should be controlled within the limits given under "General Data". Selective assembly is necessary, and for this purpose pistons are stamped with distinguishing symbols of grade and oversize.
- (7) Piston rings should have a gap clearance (see "General Data") when installed in the cylinder bores. If new rings are being installed, each

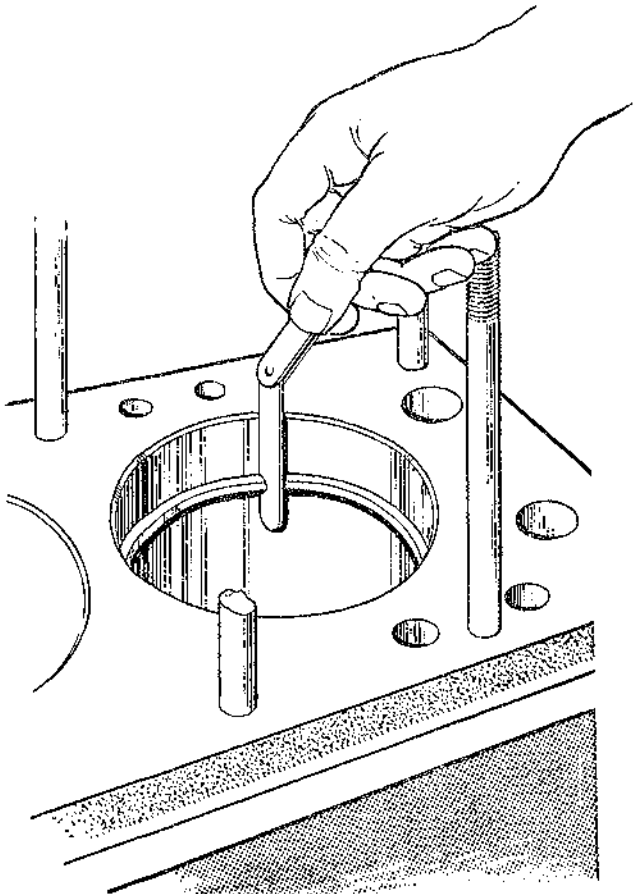

4T. 57. A.  
Fig. A.18. Checking piston ring gap.

ring should be checked in the cylinder bore to determine whether its gap clearance is within the range specified. To do this, use the bottom of a piston to insert the ring part way into the bore. The ring will be squared up in the bore to measure the gap clearance as shown in fig. A.18. To check the ring clearance in the piston grooves, install the rings on the pistons and determine the clearances with a feeler gauge. If the piston ring grooves are worn excessively, as indicated when comparing the actual clearances with those given under "General Data", renew the rings and pistons.

- (8) Gudgeon pins should be a hand-push fit in the piston. The fit can be checked after the rod has

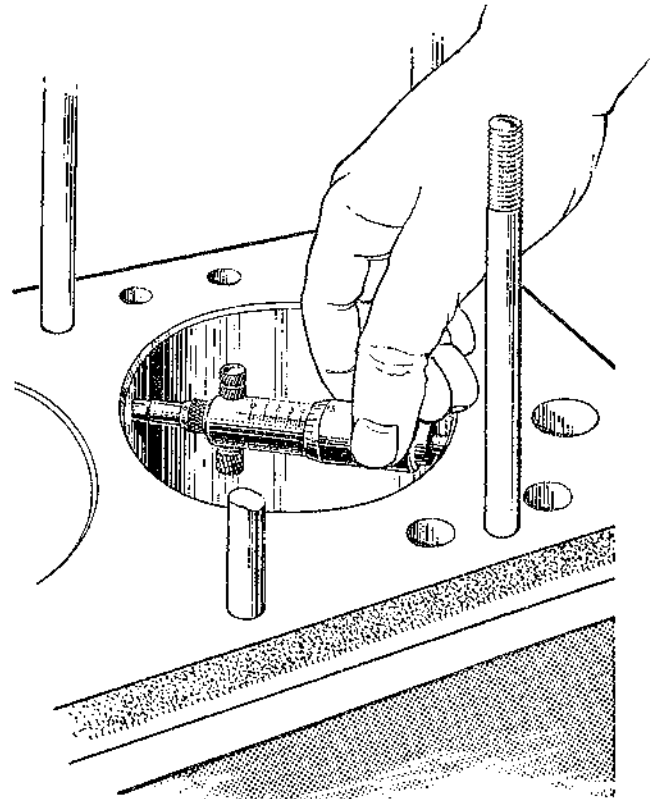

4T. 69. A.  
Fig. A.19. Checking bore wear.

been assembled by holding the piston with the connecting rod in an approximately horizontal position. The weight of the large end of the connecting rod should be just insufficient to turn the gudgeon pin in the piston. On no account must gudgeon pin piston bosses be reamed out as oversize gudgeon pins are not supplied or permitted.

**Replacement**  
See Section A.23.

## Section A.25

## TIMING CHAIN AND WHEELS

## Removal

- (1) Remove the radiator as described in Section C, if the removal is to be done with the engine in position.
- (2) Slacken the generator fixing bolts and take off the fan belt. Unscrew the starter dog nut using Service Tool No. 18G 391. Before doing this the tab washer must be knocked back.
- (3) In some cases it may now be possible to remove the crankshaft damper and pulley complete as one unit. If, however, the pulley is tight on the crankshaft, it will be necessary to undo the six nuts securing the damper, and with this component removed, draw off the pulley with Service Tool No. 18G 2.
- (4) Take out the five  $\frac{1}{4}$  in. and the seven  $\frac{5}{16}$  in. setpins from the timing cover flange, taking care to retrieve the special elongated washers fitted under the heads. The cover can now be removed and the joint washer separated, taking care to remove and retain the oil thrower.
- (5) Remove the automatic chain tensioner, see Section A.26.
- (6) Unlock and remove the camshaft chain wheel nut and remove the nut and lockwasher. Note that the locating tag on the lockwasher fits into the keyway of the camshaft chain wheel.
- (7) The camshaft and crankshaft chain wheels may now be removed, together with the timing chain, by easing each wheel forward a fraction at a time,

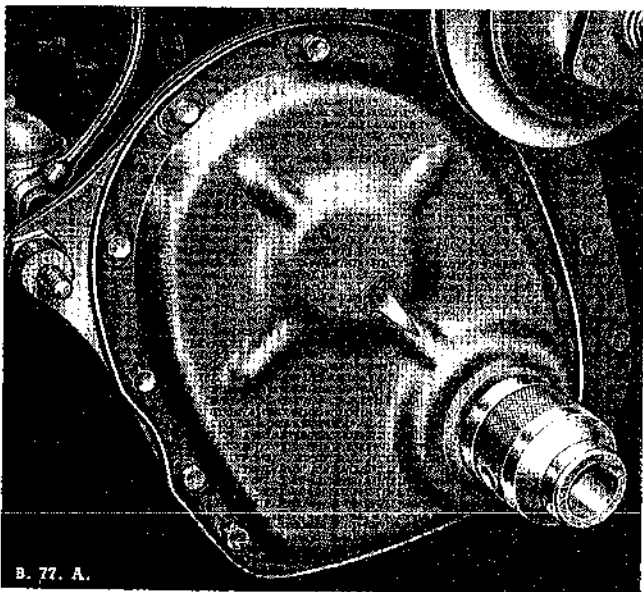

Fig. A.20. Timing cover locating tool.

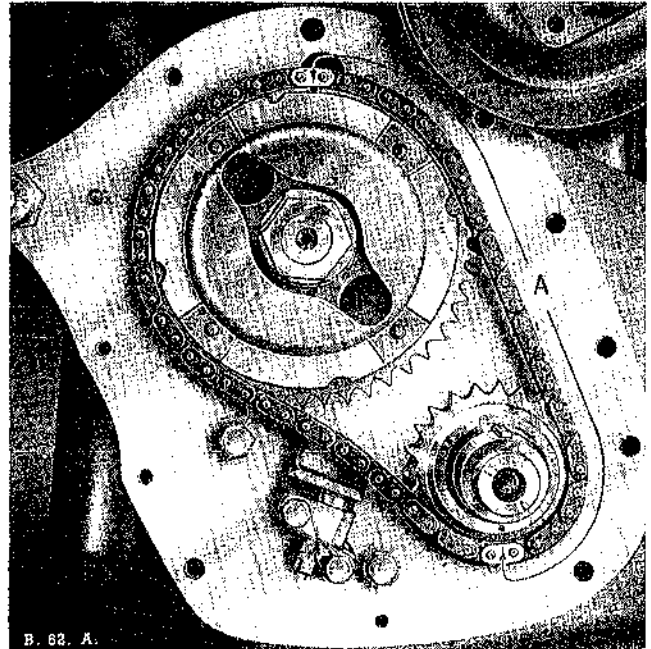

Fig. A.21. The timing chain showing bright links opposite spot marks on gears. 'A' shows the position of the short run of chain between the bright links.

with suitable small levers or Service Tool No. 18G 58. As the crankshaft gear wheel is withdrawn care must be taken not to lose the gear packing washers immediately behind it.

- (8) Clean and examine the joint faces of the timing cover and the front mounting plate.
- (9) Examine the felt oil seal for signs of wear, hardening or damage. If the slightest wear or damage is apparent the timing cover and seal must be renewed as an assembly.
- (10) Inspect chain wheels for worn, broken or chipped teeth.
- (11) Inspect the timing chain for excessive wear or stretch.
- (12) Examine the timing chain tensioner, see Section A.26.

## Reassembling

The installation of the timing chain and wheels is the reversal of the removal procedure but for the following points :---

- (1) Replace the same number of washers as was found when dismantling, unless new camshaft or crankshaft components have been fitted, which will disturb the alignment of the two gear wheels. To determine the thickness of washers required, place a straight-edge across the sides of the camshaft wheel teeth and measure with a feeler gauge the gap between the straight-edge and the crankshaft gear.

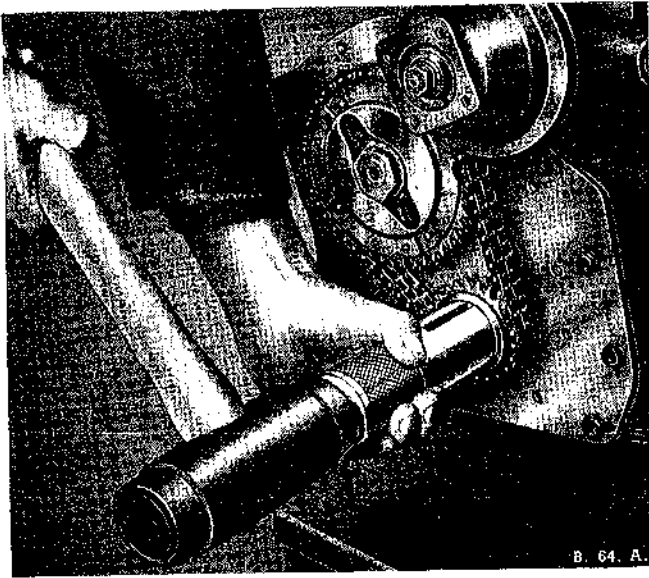

Fig. A.22. Crankshaft gear replacer tool No. 18G 16.

- (2) When replacing the timing chain and gears, set the crankshaft and camshaft with the keyways approximately at T.D.C. when seen from the front. Double the timing chain, bringing both bright links together. This gives a long and short portion of the chain on either side of the bright links. With the shorter part of the chain on the **Right**, (the bright links facing the operator), and the longer on the **Left**, engage the marked camshaft sprocket tooth with the top bright link, and the crankshaft sprocket with the marked tooth coinciding with the other bright link. Place the sprockets in their respective positions on the camshaft and crankshaft, complete with the chain, and push the assembly home. Carefully keep the sprockets in line with each other all the time to avoid straining the chain. When replaced on the engine, the bright links and the marked teeth should take up the position shown in fig. A.21.
- (3) Replace the camshaft chain wheel locking washer and nut.
- (4) Apply engine oil to the timing chain and wheels before installing the cover.
- (5) Replace the oil thrower, concave side towards the front of the engine.
- (6) Use camshaft pulley boss, or Service Tool No. 18G 3 to locate the timing cover felt washer before the timing cover flange bolts are tightened. **Note:** A new joint washer should be fitted between the timing cover and the front mounting plate.

## Section A.26

### AUTOMATIC CHAIN TENSIONER

#### Description

The timing chain tensioner is secured to the engine front mounting plate by two bolts and a locking plate. When the tensioner is in operation and the engine is running, oil from the lubrication system enters the spigot on the back face under pressure and lubricates the bearing surface through a hole in the tensioner slipper pad.

The tensioner consists of a cylinder with a helical slot which moves in a plunger by the action of a compressed spring in the tensioner body. The helical slot has a recessed lower edge. Should the chain wear through use, the spring pushes the plunger and pad outwards against the chain. A limiting peg in the plunger, bearing on the upper edge of the helical slot, rotates the cylinder until the next recess in the lower edge engages it, and the plunger is prevented from returning to its original position and allowing the chain to become slack.

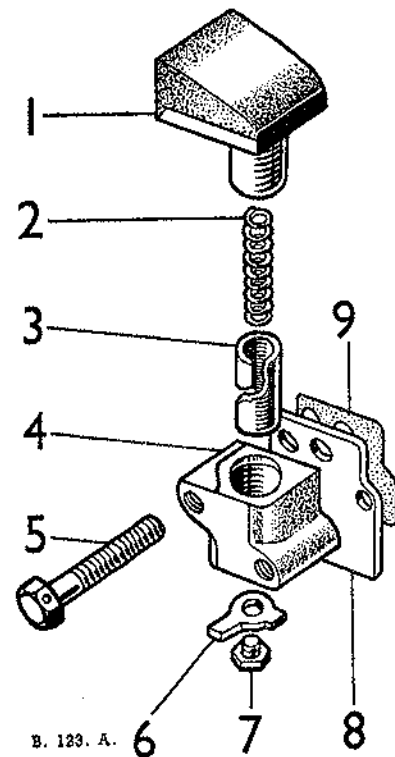

B. 129. A.

- Fig. A.23. Timing chain tensioner.
- |                     |                  |
|---------------------|------------------|
| 1. Slipper head.    | 5. Setpin.       |
| 2. Spring.          | 6. Lockwasher.   |
| 3. Locating sleeve. | 7. Plug.         |
| 4. Body.            | 8. Backplate.    |
|                     | 9. Joint washer. |

## THE ENGINE

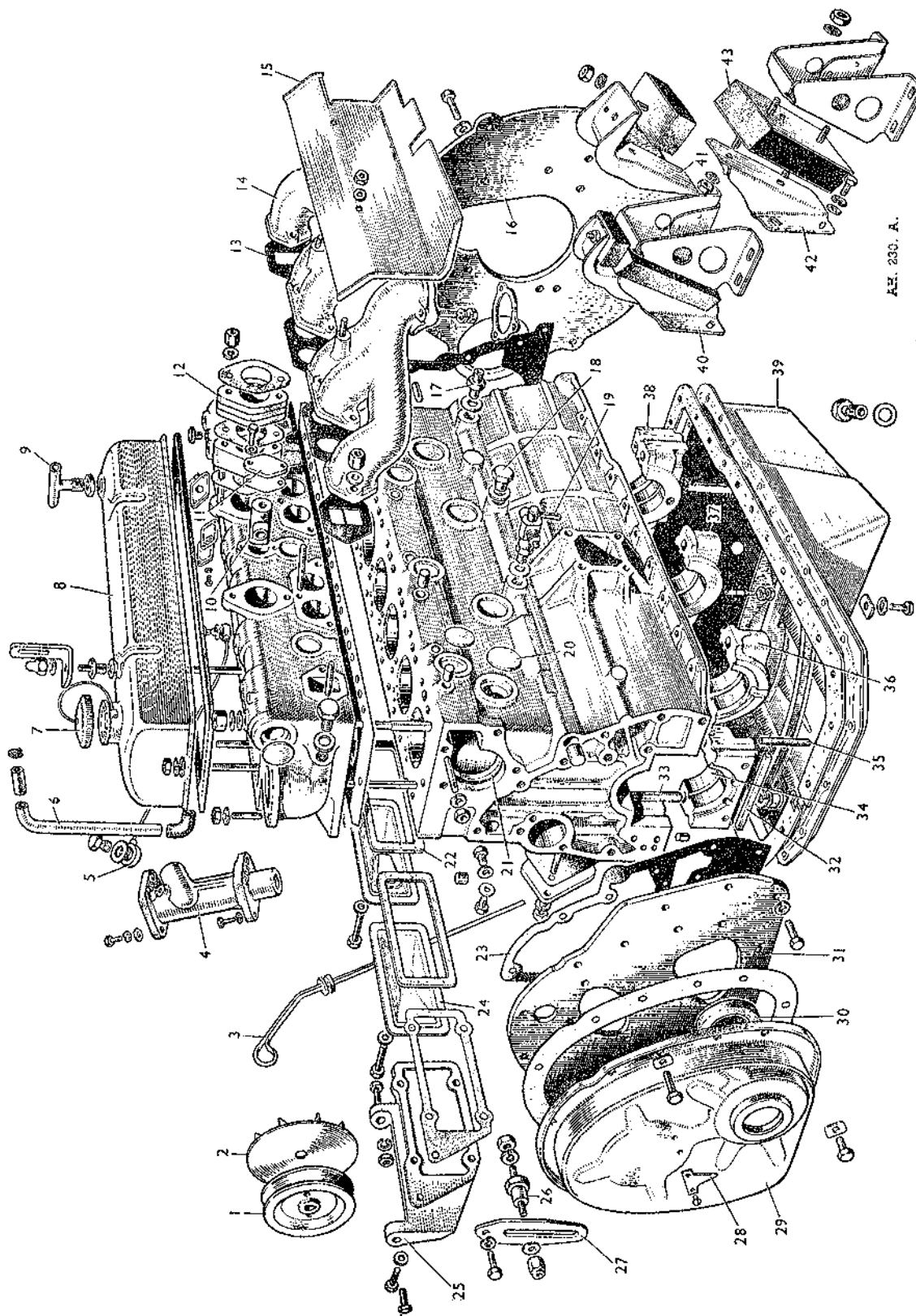

A.E. 230. A.

Fig. A.24. Engine exploded.

Fig. A.24. Engine exploded.

- |                              |                                      |                                       |
|------------------------------|--------------------------------------|---------------------------------------|
| 1. Generator pulley.         | 15. Deflector plate.                 | 30. Felt washer.                      |
| 2. Generator fan.            | 16. Engine back plate.               | 31. Engine front plate.               |
| 3. Dipstick.                 | 17. Oil gauge pipe connection.       | 32. Seal for main bearing.            |
| 4. Tachometer housing.       | 18. Plug, oil filter feed hole.      | 33. Front main bearing stud.          |
| 5. Tachometer oil feed pipe. | 19. Cylinder block drain tap.        | 34. Front main bearing cap.           |
| 6. Heater pipe.              | 20. Welch plug.                      | 35. Sump joint washer.                |
| 7. Oil filler cap.           | 21. Cylinder block.                  | 36. Centre front main bearing cap.    |
| 8. Rocker cover.             | 22. Tappet cover joint.              | 37. Centre rear main bearing cap.     |
| 9. Breather pipe.            | 23. Engine front plate joint washer. | 38. Rear main bearing cap.            |
| 10. Balance plug.            | 24. Tappet cover.                    | 39. Sump.                             |
| 11. Balance plug cover.      | 25. Generator mounting.              | 40. Engine mounting bracket.          |
| 12. Inlet manifold joint.    | 26. Generator mounting stud.         | 41. Bracket carrying mounting rubber. |
| 13. Exhaust manifold joint.  | 27. Generator swinging link.         | 42. Bracket for mounting rubber.      |
| 14. Exhaust manifold.        | 28. Timing pointer.                  | 43. Engine mounting rubber.           |
|                              | 29. Front cover.                     |                                       |

## To Remove

- (1) Unlock the tab washer fitted to the tensioner bottom plug and remove the plug from the body.
- (2) Insert a  $\frac{1}{8}$  in. (3 mm.) Allen key into the plug hole to engage the cylinder, and turn the key in a clockwise direction (viewed from the opposite end to the slipper), until the rubber slipper is completely free of spring pressure. Between a half and one full turn is necessary.
- (3) Unlock and remove the bolts to release the chain tensioner assembly and back plate.

## To Dismantle

- (1) Withdraw the plunger and slipper assembly from the tensioner body and engage the lower end of the cylinder with the Allen key.
- (2) Turn the key in an anti-clockwise direction, gripping the plunger and key securely, until the cylinder and spring are released from inside the plunger.

## To View and Overhaul

- (1) Clean the components thoroughly in petrol.
- (2) The oil hole in the spigot, and outlet oil hole in the slipper should be blown out by compressed air before reassembly.
- (3) Check the tensioner spring and examine the slipper pad for wear. Renew as an assembly if necessary.

## To Reassemble

- (1) Insert the spring in the plunger and place the cylinder on the other end of the spring.
- (2) Compress the spring until the cylinder enters the plunger bore and engages with the peg in the bore.
- (3) Hold the assembly compressed in this position and engage the Allen key. Turn the cylinder in a clockwise direction until the end of the cylinder is below the peg, thus fully compressing the spring and locking cylinder.

- (4) Withdraw the key and insert the plunger assembly into the body.

## To Replace

- (1) Position the back plate and secure the assembly to the cylinder block.
- (2) Move the timing chain into position and release the tensioner for operation by inserting the Allen key and turning it in an anti-clockwise direction as far as possible, assisting the slipper to rise initially with the finger.
- (3) Secure the bolts into their locking plate, replace the bottom plug, and lock it with a tab washer.

## Section A.27

### CAMSHAFT AND BEARINGS

#### Removal

- (1) Drain the sump and release it from the engine. Remove the oil pump, and then take off the rocker assembly, see Sections A.7, A.8 and A.12.
- (2) Remove the push rods and take out the tappets, see Section A.13.
- (3) Remove the timing cover, timing chain tensioner, chain and gears, see Sections A.24 and A.25.
- (4) Remove the distributor and spindle drive, see Section B. Do not slacken the clamping plate bolt or the ignition timing setting will be lost.
- (5) Take out the two setscrews which secure the camshaft locating plate to the cylinder block.
- (6) Withdraw the camshaft forward rotating it slowly to assist the withdrawal.
- (7) Inspect the camshaft bearing journals and cams for signs of scoring. If the journals are not within the required diameter limits (see under "General Data"), the camshaft should be renewed.
- (8) Examine the camshaft bearings for scores, pits or evidence of failure. If the bearings have to be renewed it will necessitate the removal of the

engine back plate as described in Section A.29. The old bearings can then be withdrawn and new ones installed, using Service Tools 18G 124A, 18G 124C, 18G 124E, 18G 124F, 18G 124H, 18G 124L.

Oil holes must be lined up carefully and all bearings reamed in line to give  $\cdot001$  to  $\cdot002$  in. ( $\cdot025$  to  $\cdot051$  mm.) clearance in each, using Service Tools 18G 123A, 18G 123C, 18G 123D, 18G 123E, 18G 123F, 18G 123AB, 18G 123R, 18G 123T, 18G 123AA, 18G 123L.

- (9) Inspect the tappet cam contacting surfaces for wear. New tappets should be installed wherever evidence of unusual wear is found.
- (10) The installation of the camshaft and tappets is a reversal of the procedure "Removal". Lubricate the camshaft journals with engine oil.

## Section A.28

### FLYWHEEL AND ENGINE REAR PLATE

#### To Remove

The flywheel complete with starter ring is secured to the flange on the rear of the crankshaft by four set bolts, which are locked in position by three lockplates. The engine rear plate is secured to the crankcase by set bolts and lockwashers. To remove the flywheel and rear plate, after the engine is removed from the vehicle, proceed as follows :—

- (1) Remove the gearbox from the engine (see Section F).
- (2) Remove the clutch (see Section E).
- (3) Knock back the tabs of the lockplates, unscrew the bolts and withdraw the flywheel.
- (4) Unscrew the set bolts and withdraw the engine rear plate. Note the cork sealing strip behind the engine rear plate under the crankshaft flange.
- (5) Examine the flywheel teeth and friction face for excessive wear. If the teeth on the starter ring are damaged or badly worn, a replacement flywheel and ring should be fitted.

**Note.**—The fitting of a new starter ring only, required special workshop equipment for heating the ring evenly to shrink it onto the flywheel. If these facilities are available, heat the ring to a temperature of  $1616^{\circ}$  to  $1652^{\circ}$  F. ( $880^{\circ}$  to  $900^{\circ}$  C.) before fitting.

- (6) Examine the engine rear plate for distortion and damage and clean the joint faces of the plate and crankcase and check for scores.

#### To Install

- (1) Refit the engine rear plate to the crankcase, using a new joint washer. Tighten the securing bolts evenly and firmly.

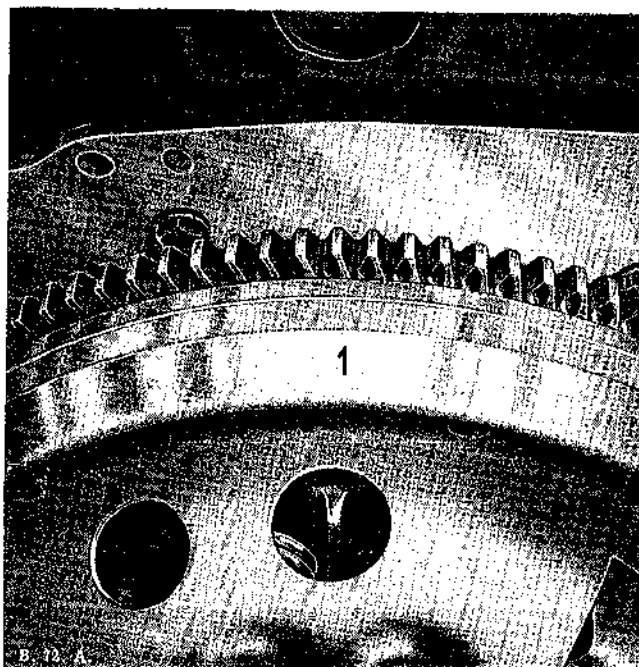

Fig. A.25. Flywheel T.D.C. mark.

- (2) Place the flywheel over the flange and flange bolts of the crankshaft so that the timing mark "1" is at T.D.C. when the first throw of the crankshaft is at T.D.C. The joint faces should be perfectly clean. Fit the lockplates and nuts on the bolts and tighten them in diagonal sequence.

## Section A.29

### CRANKSHAFT AND MAIN BEARINGS

#### To Remove

The forged-steel crankshaft is statically and dynamically balanced and is supported in the crankcase by three renewable main bearings of the sintered copper and lead steel-backed type. Crankshaft end float is controlled by thrust washers fitted on both sides of the centre main bearing.

- (1) Remove the engine from the vehicle (see Section A.4) and place it upside-down in a dismantling fixture.
- (2) Remove the sump and oil strainer (see Section A.7).
- (3) Remove the timing chain (see Section A.25).
- (4) Remove the flywheel and engine rear plate (see Section A.28).
- (5) Check the crankshaft end float to determine whether the renewal of the thrust washers is necessary.
- (6) Remove the connecting rod bearing caps and shells, keeping the shells with their respective caps for correct replacement, and release the connecting rods from the crankshaft. Remove



the sparking plugs from the cylinder head to facilitate the turning of the crankshaft.

- (7) Withdraw the main bearing caps complete with bearing bottom shells. Caps and both bearing half-shells should be kept together. The use of Service Tool 18G 42 will assist in the removal of the bearing caps. Remove the screwed plug from the rear bearing cap oil return pipe and withdraw the pipe in order to use the extractor. Note that each main bearing is stamped with a common number, which is also stamped on the centre web of the crankcase near the main bearing. The bottom halves of the two thrust washers will be removed with the centre main bearing cap. Safeguard the cork sealing strips.
- (8) Remove the crankshaft, the two remaining halves of the thrust washers and the top half-shells of the main bearings from the crankcase.
- (9) Inspect the crankshaft main journals and crankpins for wear, scores, scratches and ovality. If necessary the crankshaft may be re-ground to the minimum limits shown under "General Data". Main bearings for re-ground crankshafts are available in sizes shown under "General Data".
- (10) Clean the crankshaft thoroughly, ensuring that the connecting oilways between the journals and crankpins are perfectly clear. They can be cleaned out by applying a pressure gun containing petrol or paraffin. When clean, inject a thin oil in the same manner.
- (11) Thoroughly clean the bearing shells, caps and housings above the crankshaft.
- (12) Examine the bearing shells for wear and pitting, and look for evidence of breaking away or picking-up. Renew the shells if necessary.
- (13) Bearings are pre-finished with the correct diametrical clearance, and do not require bedding in. New bearings should be marked to match up with the marking on the cap, and **on no account should they be filed to take up wear or to reduce running clearance.**
- (14) Check the thrust washers for wear on their bearing surfaces, and renew if necessary to obtain the correct end float.

### To Install

The installation of the crankshaft and main bearings is a reversal of the procedure "To Remove", noting the following points:—

- (1) Ensure that the thrust washers are replaced the correct way round and locate the bottom half tab in the slot in the bearing cap.
- (2) The bearing shells are notched to fit the recesses machined in the housing and cap.

- (3) In the case of the front and rear main bearing caps, install new cork sealing strips.
- (4) Lubricate the bearings freely with engine oil.
- (5) Tighten the main bearing nuts, see "General Data" for torque spanner settings.

## Section A.30

### CYLINDER BLOCK

#### To Remove and Dismantle

- (1) Remove and dismantle the engine (see Section A.4).
- (2) Remove all studs, unions and screwed plugs, etc., if necessary.
- (3) If an expansion plug has blown, or leaks, remove the plug by drilling a hole in its centre and lever it out with a screwdriver or other suitable tool.

#### To View and Overhaul

- (1) Scrape as much sediment as possible from the water passages and thoroughly swill out with a water hose.
- (2) Clean all gasket surfaces.
- (3) Inspect for cracks and scores on gasket surfaces.
- (4) It may be advisable to remove the ridge above the ring travel at the top of the cylinder bores before checking the fit of the pistons.
- (5) Wipe the cylinder bores clean and examine them for scores, out-of-round and taper. If the cylinders are found to be out-of-round or excessively tapered when measured with a dial test indicator, they should be reconditioned.
- (6) If cylinder reconditioning is required, determine accurately the amount of material to be removed (refer to "General Data" concerning oversize pistons available).
- (7) Make sure that all traces of abrasives are cleaned from all parts of the cylinder block after the cylinder reconditioning operation is completed.
- (8) Check the camshaft bearings (see Section A.27).

#### To Reassemble and Install

- (1) Install all studs, unions and screwed plugs, etc.
- (2) When installing new expansion plugs, coat the edge of the plug with a sealing compound and insert the plug with the "bulge" on the outside. A carefully aimed blow at the centre of the plug with a small hammer direct or with a blunt punch will expand the plug sufficiently to make a water-tight joint. If too heavy a blow is used, the plug will be useless and must be replaced by another new one.
- (3) Reassemble, install and test the engine (see Section A.4).

# A

## THE ENGINE

### Section A.31

### FAULT DIAGNOSIS

Symptom	No.	Possible Fault
(a) Will Not Start	1 2 3 4 5 6 7 8 9 10 11 12 13 14 15 16 17	Defective coil Faulty condenser Dirty, pitted, or incorrectly set contact breaker points Ignition wires loose or leaking Water on sparking plugs leads Corrosion of terminals or discharged battery Faulty starter Wrongly connected plug leads Vapour lock in fuel line Defective fuel pump Over-choking Under-choking Choked petrol filter or jets Valves leaking Sticking valves Valve timing incorrect Ignition timing incorrect
(b) Engine Stalls	1 2 3 4 5 6	In (a), check 1, 2, 3, 4, 10, 11, 12, 13, 14 and 15 Plugs defective or incorrect gap Retarded ignition Mixture too weak Water in fuel system Petrol tank breather choked Incorrect valve clearance
(c) Poor Idling	1 2 3 4 5 6 7 8	In (b), check 1 and 6 Air leak at manifold joints Incorrect slow running adjustment Air leak in carburettor(s) Slow running jet choked Over-rich mixture Worn piston rings Worn valve stems or guides Weak exhaust valve springs
(d) Misfiring	1	In (a), check 1, 2, 3, 4, 5, 8, 10, 13, 14, 15, 16 and 17 In (b), check 1, 2, 3 and 6 Weak or broken valve springs
(e) Overheating		See Section C
(f) Low Compression	1 2	In (a), check 14 and 15 In (c), check 6 and 7 In (d), check 1 Worn piston ring grooves Scored or worn cylinder bores

# THE ENGINE

**A**

## FAULT DIAGNOSIS

Symptom	No.	Possible Fault
(g) Lack of Power	1	In (a), check 3, 10, 11, 13, 14, 15 and 16
	2	In (b), check 1, 2, 3 and 6
	3	In (c), check 6 and 7 In (d), check 1 Check (e) and (f) Leaking joint washers Fouled sparking plugs Automatic advance not functioning
(h) Burnt Valves or Seats	1	In (a), check 14 and 15 In (b), check 6 In (d), check 1 Check (e) Excessive carbon around valve seat and head
(j) Sticking Valves	1	In (d), check 1
	2	Bent valve stem
	3	Scored valve stem or guide Incorrect valve clearance
(k) Excessive Cylinder Wear	1	Check 11 in (a)
	2	Check (e)
	3	Lack of oil
	4	Dirty oil
	5	Dirty air cleaner
	6	Gummed up or broken piston rings Badly fitting piston rings Misalignment of conrods
(l) Excessive Oil Consumption	1	In (c), check 6 and 7
	2	Check (k)
	3	Ring gap too wide
	4	Oil return holes in piston choked with carbon
	5	Scored cylinders
	6	Oil level too high External oil leaks Ineffective valve oil seal
(m) Crankshaft and Connecting Rod Bearing Failure	1	In (k), check 1
	2	Restricted oilways
	3	Worn journals on crankpins
	4	Loose bearing caps
	5	Extremely low oil pressure Bent connecting rod
(n) Internal Water Leakage		See Section C.

# A

## THE ENGINE

### FAULT DIAGNOSIS

Symptom	No.	Possible Fault
(o) Poor Circulation		See Section C
(p) Corrosion		See Section C
(q) High Fuel Consumption		See Section D
(r) Engine Vibration	1	Loose generator bolts
	2	Fan blades out of balance
	3	Incorrect clearance for engine front mounting rubbers
	4	Gearbox tensioner rubber or stabiliser bar incorrectly adjusted
	5	Exhaust pipe mountings too tight

### MODIFICATION REFERENCES

<i>Service Reference Number</i>	<i>Date</i>	<i>Subject</i>	<i>Details of Changes</i>

# **SECTION B**

## **IGNITION**

Section No. B.1	Description
Section No. B.2	Adjustments in the vehicle
Section No. B.3	To test in the vehicle
Section No. B.4	Ignition coil
Section No. B.5	Distributor
Section No. B.6	Distributor driving spindle
Section No. B.7	High-tension cables
Section No. B.8	Sparking plugs
Section No. B.9	Fault diagnosis

---



## Section B.1

### DESCRIPTION

The ignition system consists of two circuits—primary and secondary. The primary circuit includes the battery, ignition switch, the primary or low-tension circuit of the coil and the distributor contact breaker and capacitor. The secondary circuit includes the secondary or high-tension circuit of the coil, the distributor rotor and cover segments, the high-tension cables and the sparking plugs.

The ignition coil, which is mounted on the right-hand side of the engine, consists of a soft iron core around which is wound the primary and secondary windings. The coil carries at one end a centre high-tension terminal and two low-tension terminals marked (SW) (switch) and (CB) (contact breaker) respectively.

The ends of the primary winding are connected to the (SW) and (CB) terminals and the secondary winding to the (CB) terminal and the high-tension terminal.

The distributor is mounted on the right-hand side of the engine and is driven by a shaft and helical gear from the camshaft. Automatic timing control of the distributor is controlled by a centrifugal mechanism and a vacuum-operated unit each operating entirely independently of each other. The centrifugal mechanism regulates the ignition advance according to engine speed, while the vacuum control varies the timing according to engine load. The combined effect of the two mechanisms gives added efficiency over the full operating range of the engine. A micrometer adjuster is provided to give a fine timing adjustment to allow for the engine condition and the grade of fuel used.

A keyed moulded rotor with a metal electrode is mounted on top of the cam. Attached to the distributor body above the centrifugal advance mechanism is a contact breaker plate carrying the contact breaker points and a capacitor connected in parallel. A cover is fitted over the distributor body and retained by two spring clips attached to the body.

Inside the cover is a centre electrode and spring-loaded carbon brush which makes contact with the rotor. The brush is of composite construction, the top portion being made of a resistive compound, while the lower portion is made of softer carbon to prevent wear of the rotor electrode. Under no circumstances must a short non-resistive brush be used to replace this long resistive type. A measure of radio interference suppression is given by this brush.

Spaced circumferentially around the centre electrode are the sparking plug high-tension cable segments. The distributor is secured in position on the cylinder block by a clamp plate.

The sparking plugs are located on the right-hand side

of the engine and have a 14 mm. thread with a  $\frac{1}{4}$  in. reach.

When the ignition is switched on, the current from the battery flows through the primary circuit, and a magnetic field is built up around the core of the coil. When the contact breaker points are opened by rotation of the distributor cam, the current flow is interrupted, causing a high voltage to be induced in the secondary winding of the coil by sudden collapse and consequent change in the magnetic field. The high-tension current thus generated in the secondary winding of the coil is conveyed by the coil high-tension cable to the centre terminal of the distributor cover. From here the current passes through the carbon brush to the rotor, where the high-tension current passes along the rotor electrode and is distributed to the segments and thence to the sparking plugs via the high-tension cables.

## Section B.2

### ADJUSTMENTS IN THE VEHICLE

The purpose of the following adjustments is to maintain efficient engine performance and economical running.

- (1) Adjust the sparking plugs at the recommended intervals as follows:—

The gap of the plug points should be within the limits of .024 to .026 in. (.61 to .66 mm.).

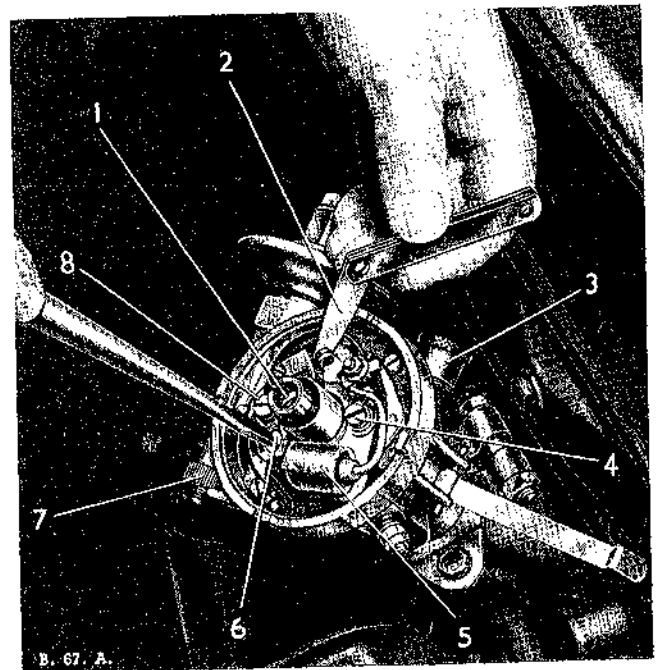

*Fig. B.1. Contact breaker adjustment.*

- |                            |                             |
|----------------------------|-----------------------------|
| 1. Oiling point.           | 5. Condenser.               |
| 2. Feeler gauge.           | 6. Contact adjusting screw. |
| 3. Shaft lubricator.       | 7. Micrometer adjuster.     |
| 4. Contact locking screws. | 8. Contact locking screws.  |

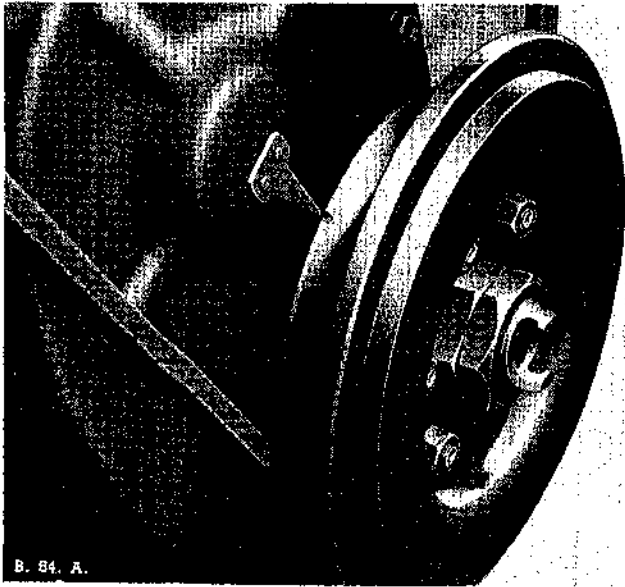

B. 24. A.

Fig. B.2. Showing the timing pointer set opposite to the notch in the crankshaft pulley. (Number 1 piston at T.D.C.)

Gap adjustment should be made by bending the side electrode only. Never bend the central electrode. If the plugs are dirty, damaged or excessively burned, see Section B.1.

- (2) Adjust the contact breaker points at the recommended intervals as follows :—

Remove the distributor cover and rotor. Rotate the engine with the starting handle until the fibre heel of the rocker is on the peak of one of the cam lobes. The gap of the contact breaker points should be within .014 to .016 in. (.36 to .40 mm.).

Gap adjustment should be made by slackening the fixed contact plate securing screws and moving the plate until the gap gauge is a sliding fit between the two contacts. Tighten the securing screws and recheck the gap. Replace the rotor and cover. If the points are dirty or pitted see Section B.5.

- (3) Adjust the ignition timing, if the distributor has been disturbed, as follows :—

Remove the cylinder head cover so that the valve action can be observed. Rotate the engine with the starting handle until No. 1 piston is at the top of its compression stroke (*i.e.* the exhaust valve of No. 6 cylinder is just closing and the inlet valve just opening). Turn the crankshaft until the recess in the crankshaft pulley flange is in line with the pointer on the timing chain cover (see Fig. B.2). If the timing chain cover has been removed, align the bright links on the timing chain with the marked teeth on the camshaft and crankshaft sprockets (see Section A.25) when

No. 6 and No. 1 pistons will be at T.D.C. Set the micrometer adjustment on the distributor to its central position. The crankshaft should now be rotated backwards  $6^\circ$  to obtain its correct position before setting the distributor points, this setting is correct for premium grade fuels only. With the cover removed the distributor body must be rotated until the rotor arm is pointing to the position of No. 1 electrode in the cover. With the contact points just opening, tighten the clamp plate bolt.

Finer adjustment can be obtained under road conditions, by means of the micrometer adjustment. Note this adjustment should not be used for initial setting of the ignition; it is only altered if the main setting requires adjustment to meet the characteristics of the grades of petrol being used. There is a considerable amount of latitude for adjustment, but only extremely small movement of the adjustment knob should be made at one time.

Replace the distributor cover and cylinder head cover.

## Section B.3

### TO TEST IN THE VEHICLE

If the ignition system fails, or misfiring occurs, first make sure that the trouble is not due to defects in the engine, carburetter or fuel supply. Faults should be diagnosed by applying the following tests :—

- (1) Examine the high-tension cables, *i.e.* the cables from the coil to the distributor, and from the distributor to the plugs. If the rubber insulation shows signs of deterioration or cracking, the cable should be renewed.
- (2) Test the plugs and high-tension cables by removing the plugs in turn and allowing them to rest on the cylinder head or other convenient earthing point, and observing whether a spark occurs at the points when the engine is turned by hand. It should, however, be noted that this is only a rough test, since it is possible that a spark may not take place when the plug is under compression. If necessary, clean and test the plugs, using a plug cleaning and testing machine.
- (3) To trace a fault in the low-tension circuit, release the instrument panel from the dash, switch on the ignition, and turn the engine until the distributor contacts are opened. Refer to the wiring diagram, Fig. N.25, and, with the aid of a voltmeter (0 to 20), check the circuit as follows :—

#### (a) Cable—Battery to starter switch

Connect the voltmeter between the supply terminal of the starter switch and an earthing



## IGNITION SYSTEM

point. No reading indicates a faulty cable or loose connection.

- (b) **Cable (brown)—Starter switch to two-way fuse unit A.1 terminal**

Connect the voltmeter between the fuse unit A.1 terminal and earth. No reading indicates a faulty cable or loose connection.

- (c) **Control box**

Connect the voltmeter between the control box terminal (A.1) and earth. No reading indicates a faulty control box.

- (d) **Cable (brown and blue)—Control box to lighting and ignition switch**

Connect the voltmeter between the lighting switch terminal (A) and earth. No reading indicates a faulty cable or loose connection.

- (e) **Ignition switch**

Connect the voltmeter between the ignition switch (white cable terminal) and earth. No reading indicates a faulty ignition switch.

- (f) **Cable (white)—Ignition switch to fuse unit A.3 terminal**

Connect the voltmeter between the fuse unit A.3 terminal and earth. No reading indicates a faulty cable or loose connection.

- (g) **Cable (white)—Fuse unit A.3 terminal to ignition coil**

Connect the voltmeter between the ignition coil terminal (SW) and earth. No reading indicates a faulty cable or loose connection.

- (h) **Ignition coil**

Connect the voltmeter between the ignition coil terminal (CB) and earth. No reading indicates a faulty ignition coil.

- (i) **Cable (white and black)—Ignition coil to distributor**

Connect the voltmeter between the distributor terminal and earth. No reading indicates a faulty cable or loose connection.

- (j) **Distributor**

Connect the voltmeter across the distributor contacts. If no reading is given, remove the capacitor and test again. If a reading is given, the capacitor is faulty.

- (5) If, after carrying out the foregoing tests, the fault has not been located, remove the high-tension cable from the centre terminal of the distributor. Switch on the ignition and crank the engine until the contacts close. Flick the contact breaker lever open while the high-tension cable from the ignition coil is held about  $\frac{3}{16}$  in. (5 mm.) away from the cylinder block. If the ignition equipment is in order a strong spark should be obtained. If no spark is given, it indicates a faulty ignition coil.

### Section B.4

#### IGNITION COIL.

##### To remove

- (1) Disconnect the high-tension cable from the coil centre terminal.
- (2) Disconnect the low-tension cables from the (SW) and (CB) terminals of the coil.
- (3) Unscrew the bolts fastening the coil to the generator strap, and remove the coil.

##### To install

The installation of the ignition coil is a reversal of the procedure "To remove".

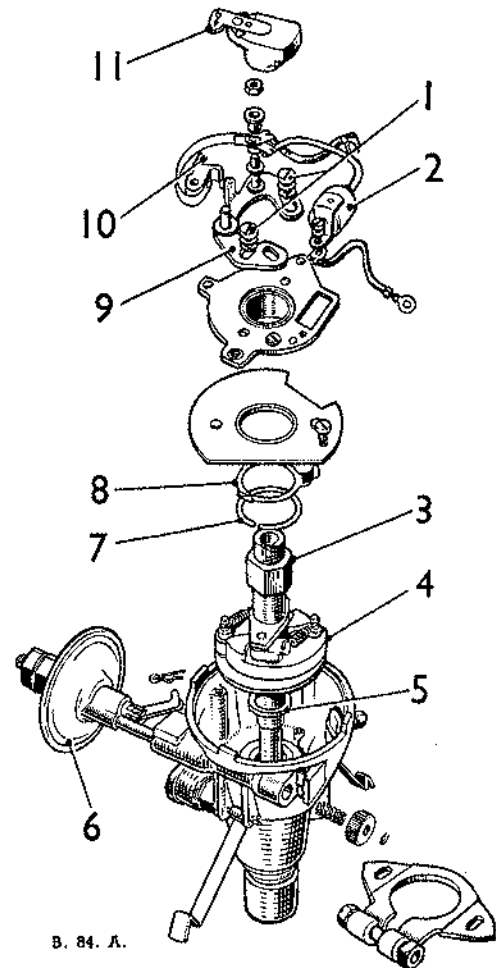

B. 84. A.

Fig. B.3. Distributor exploded.

- |                              |                         |
|------------------------------|-------------------------|
| 1. Screws for contact plate. | 6. Vacuum control.      |
| 2. Condenser.                | 7. Felt ring.           |
| 3. Cam.                      | 8. Spring.              |
| 4. Automatic timing contact. | 9. Fixed contact plate. |
| 5. Distance collar.          | 10. Moving contact.     |
|                              | 11. Rotor.              |

# B

## IGNITION SYSTEM

### Section B.5

#### DISTRIBUTOR

##### To remove

- (1) Disconnect the high-tension cables from the sparking plugs.
- (2) Disconnect the high-tension cable from the centre terminal of the ignition coil.
- (3) Disconnect the low-tension cable from the terminal on the side of the distributor.
- (4) Disconnect the vacuum control pipe at the union.
- (5) Unscrew and remove the tachometer drive and tachometer drive oil feed pipe.
- (6) Remove the two set bolts attaching the clamp plate to the tachometer drive housing and withdraw the distributor from the tachometer housing.  
**Do not loosen the clamp plate.**

##### To dismantle

- (1) Spring back the two securing clips and remove the distributor cover.
- (2) Unscrew the terminal screws from the distributor cover and withdraw the high-tension cables.
- (3) Remove the rotor.
- (4) Take out the split pin securing the vacuum link to the sliding contact breaker plate and remove the two screws at the edge of the contact breaker base.
- (5) Slacken the two nuts on the low tension terminal and pull the connection on the contact breaker away from the terminal block. Lift out the contact breaker assembly.
- (6) Remove the nut, insulating piece and connections from the pillar on which the contact breaker spring is anchored, and lift off the contact breaker lever and the insulating washers beneath it.
- (7) Remove the two screws securing the fixed contact plate, together with their spring and plain washers and take off the plate.
- (8) Withdraw the single screw securing the capacitor and contact breaker earthing lead. The contact breaker base assembly can be dismantled by removing the circlip and star washer located under the lower plate.
- (9) Remove the circlip on the end of the micrometer timing screw and turn the micrometer nut until the screw and vacuum assembly are freed, take care not to loosen the ratchet and coil springs located under the micrometer nut.
- (10) Tap out the parallel pin securing the driving dog and tachometer gear to the lower end of the spindle. The driving dog and tachometer gear can then be removed.
- (11) Unscrew and remove the lubricator from the

distributor body together with its spring and felt washer.

- (12) The distributor shaft, cam and centrifugal timing control can be pressed upwards through the distributor body.
- (13) Remove the cam fixing screw from the top of the driving shaft and withdraw the cam and centrifugal timing control.  
**Note:** A distance collar is fitted on the shaft underneath the action plate.
- (14) Clean the distributor cover and examine it for signs of cracks and evidence of "tracking", *i.e.* a conducting path may have formed between adjacent segments. This is indicated by a thin black line between the segments; when this has occurred the cover should be renewed.
- (15) Ensure that the carbon brush moves freely in the distributor cover.
- (16) Examine the attachment of the metal electrode to the rotor moulding. If slack or abnormally burned, renew the rotor.
- (17) The contact face of the contact breaker points should present a clean, greyish, frosted appearance. If burned or blackened, renew the contact set or polish the contact face of each point with a fine oil-stone, working with a rotary motion. Care should be taken to maintain the faces of the points flat and square, so that when reassembled full contact is obtained. Clean the points thoroughly in petrol.
- (18) Check that the movable contact arm is free on its pivot without slackness.

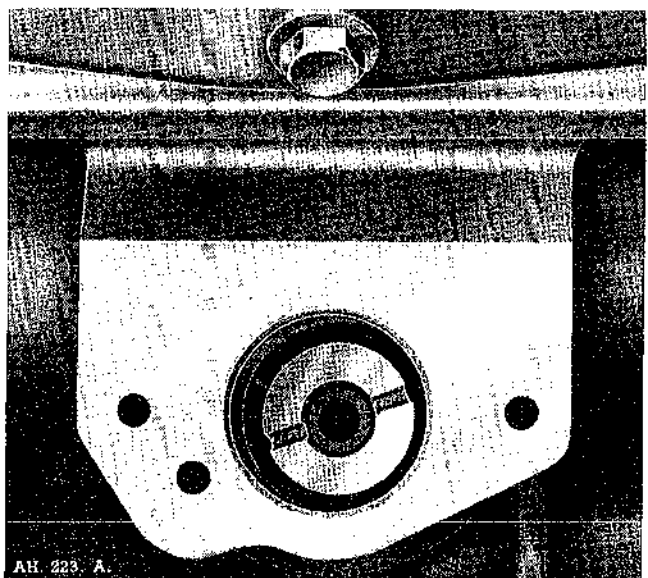

Fig. B.4. Distributor drive, showing the slot in the "Twenty-to-two" position.

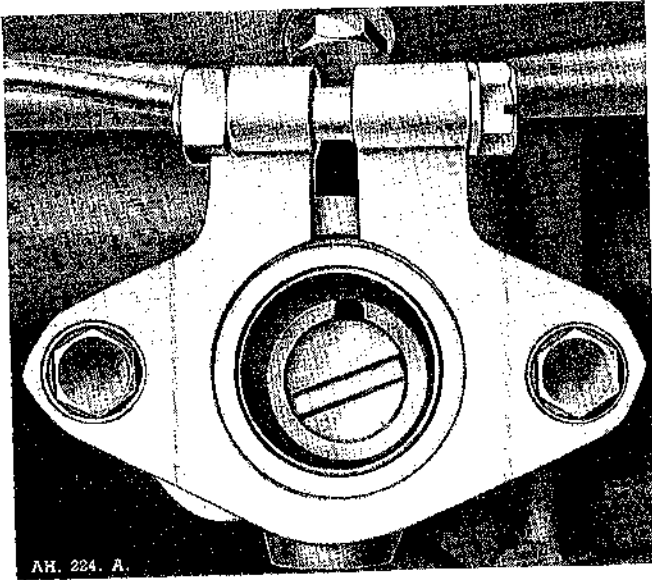

Fig. B.5. Tachometer spindle, showing the smaller segment of the offset dog in the downward position.

- (19) Check the centrifugal timing control balance weights and pivot pins for wear and renew the cam assembly or weights if necessary.
- (20) The cam assembly should be a free sliding fit on the driving shaft. If the clearance is excessive, or the cam face is worn, renew the cam assembly or shaft as necessary.
- (21) Check the fit of the shaft in the body bearing bushes. If slack, renew the bushes and shaft, as necessary.

Press out the old bushes. The new bushes should be allowed to stand completely immersed in thin engine oil for twenty-four hours, or alternatively for two hours in oil which has been heated to 212° F. (100° C.), before pressing them into the distributor body.

### To reassemble

Reassembly of the distributor is a reversal of the procedure "To dismantle", noting the following points:—

- (1) Apply a few drops of engine oil to the centrifugal timing control mechanism and cam bearing.
- (2) Lightly smear the cam surface with engine oil.
- (3) Apply a drop of engine oil to the top of the pivot on which the moving contact fibre rocker arm works.
- (4) Secure the distributor driving dog to the driving spindle with a new peg, ensuring that the small offset of the driving tongue is on the right when the rotor arm driving slot is downwards.
- (5) Connect the internal cables as follows:—
  - (a) Red cable, capacitor to contact breaker spring anchor post.

- (b) Cable, low-tension terminal to contact spring anchor post.
  - (c) Cable, base plate locating screw to capacitor locating screw.
- (6) Adjust the contact breaker points to the instructions given in Section B.2.
  - (7) Reassemble the high-tension cables to the distributor to the instructions given in Section B.7.
  - (8) Turn the vacuum control adjusting nut to the half-way position when refitting the unit.

### To Install

Replacing the distributor to the reverse of the procedure "To Remove", noting the following points:—

- (1) Insert the assembled distributor, with its cap removed, into the tachometer housing and turn the rotor arm until the driving slot on the distributor engages with the dog in the housing.
- (2) Turn the distributor body to align the clamping plate holes with their respective holes on the tachometer housing and not the set bolts.
- (3) Check the contact breaker gap and ignition timing as described in Section B.2.

## Section B.6

### DISTRIBUTOR DRIVING SPINDLE

#### Removal

- (1) Remove the distributor as described in Section B.5.
- (2) Release the three setscrews which secure the tachometer housing to the cylinder block and withdraw the housing.
- (3) By using a  $\frac{5}{16}$  in. U.N.F. bolt approximately 3½ in. long, screwed into the tapped end of the drive spindle, the spindle can be withdrawn.
- (4) Examine the drive gear for worn teeth.

#### To Replace

- (1) Remove the valve gear cover (see Section A).
- (2) Crank the engine until No. 1 piston is at the top of its compression stroke (*i.e.* the exhaust valve of No. 6 cylinder is just closing and the inlet valve just opening).
- (3) Turn the crankshaft until the recess in the crankshaft pulley flange is in line with the (T.D.C.) indicating pointer on the timing chain cover (see Fig. B.2).
- (4) Screw the  $\frac{5}{16}$  in. U.N.F. bolt into the threaded end of the distributor drive and replace the drive in the block so that the centrally cut slot takes up the position shown in Fig. B.4 (*i.e.* "twenty-to-two" position).
- (5) Replace the tachometer housing, rotating the external drive dog until it mates up with the slot

# B

## IGNITION SYSTEM

in the distributor driving spindle. Ascertain that the smaller segment of the offset dog, situated within the tachometer housing is in the downward position.

**Note:** The internal dog should now be in the "twenty-to-two" position, see Fig. B.5. Secure the tachometer housing to the block with its three setpins.

- (6) Replace the distributor following the instructions given in Section B.5.

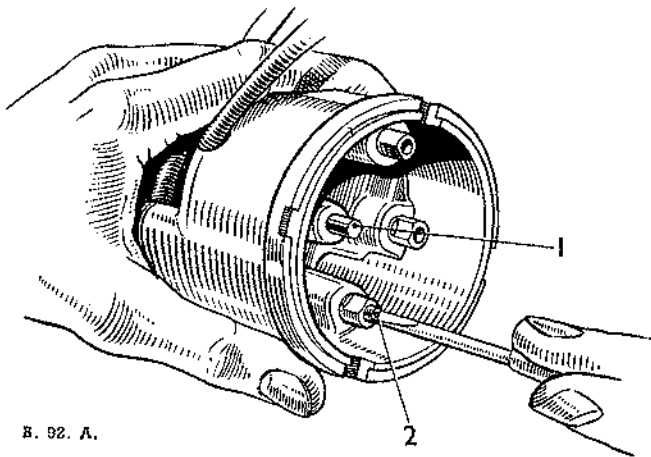

Fig. B.6. Distributor cap.

1. Carbon brush. 2. Screw securing cable.

### Section B.7

#### HIGH-TENSION CABLES

##### To remove

- (1) Obtain access to the high-tension cables by removing the engine top cowl.
- (2) Pull the high-tension cable off the sparking plug.
- (3) Unscrew the moulded terminal to release the cable from the coil.
- (4) Straighten out the bare strands of cable, remove the brass washer and withdraw the cable from the moulded terminal.
- (5) Release the screw securing the cable in the distributor cover and withdraw the cable.

##### To Replace

- (1) Thread the cable through the moulded terminal and brass washer and bend back the bare strands of the cable against the brass washer.
- (2) Push the cable into the distributor cover and secure it with the pointed screw.
- (3) Install the cables in the coil and distributor cover and onto the sparking plugs in the correct order. The firing order is 1, 5, 3, 6, 2, 4, following round in an anti-clockwise direction.

### Section B.8

#### SPARKING PLUGS

The sparking plugs are of the long reach 14 mm. type, Champion N.A.8.

The gaps of these plugs should be maintained at .024 to .026 in. (.6096 to .660 mm.). If the gap is allowed to become too wide, misfiring at high speeds is liable to occur; and if too small, bad slow running and idling will be the result.

Sparking plugs should be regularly inspected, cleaned and tested. This is of vital importance to ensure good engine performance, coupled with fuel economy.

When removing the plugs from the engine, use a box spanner, this will avoid possible damage to the insulators. Always remove the copper washers. The plugs should then be placed in a suitable holder which has holes drilled to admit the upper end of the plugs and marked to identify each one with the cylinder from which it was removed.

The plugs should now be carefully examined.

Oil fouling will be indicated by a wet shiny black deposit on the insulator. This condition is usually caused by worn cylinders, pistons or gummed rings. Oil vapour is forced from the crankcase, during the suction stroke of the piston which fouls the plugs.

Petrol fouling will cause a dry, fluffy, black deposit to be apparent on the plugs. This is usually caused by faulty carburation, but a faulty coil or leaking and worn out ignition leads, may have the same effect.

Under the above conditions, if the plugs otherwise appear to be sound, they should be cleaned thoroughly, adjusted, and tested.

When preparing for cleaning, the plug washers should be removed and examined. The condition of these washers is important in that a large proportion of the heat from the plug insulator is dissipated to the cylinder head by them. The washer should therefore be reasonably compressed. A loose plug can be easily overheated, thus shortening plug life. On the other hand, do not over-tighten. All that is needed is a good seal between the cylinder head and the plug. Tightening too much will cause distortion of the washer with the possibility of blow-by which will again lead to overheating and resulting danger. If there is any question of defect, replace with new washers.

The plugs should now be thoroughly cleaned of all carbon deposit, resorting to scraping if necessary, removing as much as possible from the space between the insulator and shell. An oily plug should be washed out with petrol. If a plug cleaning machine is available, 5 to 10 seconds in this will remove all remaining signs of carbon. Remember to thoroughly "blow-out" the

**IGNITION SYSTEM**

plug after treatment under these conditions, in order to remove all traces of abrasive.

After cleaning, thoroughly examine the plug for cracked insulator or worn away insulator nose. Should either of these conditions be apparent a new plug should be installed.

Carbon deposit on the threads of the plugs, should be carefully removed by using a wire brush, or if available a wire buffing wheel. Take care not to damage the electrodes or insulator tip. This often neglected cleaning operation will lead to tight threads and resultant loss of heat dissipation due to the carbon deposit, thereby causing overheating.

The condition of the electrodes should now be noted and any signs of corrosion removed, if it is felt that the plugs are worthy of further use. This can be carried out with the use of a small file to carefully dress the gap area. The gap should then be reset, to a clearance of .024 to .026 in. (.6096 to .660 mm.). When resetting bend the side electrode only.

It is advisable whilst the plugs are under pressure in the testing machine, to apply a spot of oil to the terminal end, to check for air leakage. Excessive leakage here will tend to cause compression loss, rapid deterioration of the electrode and overheating of the electrode tip. The top half of the insulator should also be carefully examined for any paint splashes or accumulation of grime and dust, which should be removed. Should there be any signs of cracks due to faulty use of the

spanner, the plug should be renewed. When replacing the plug lead, make sure that it is securely attached.

Make plug inspection, cleaning and testing a routine job and carry this out at least every 6,000 miles. Remember, plugs in good condition will ensure better fuel consumption and good engine performance.

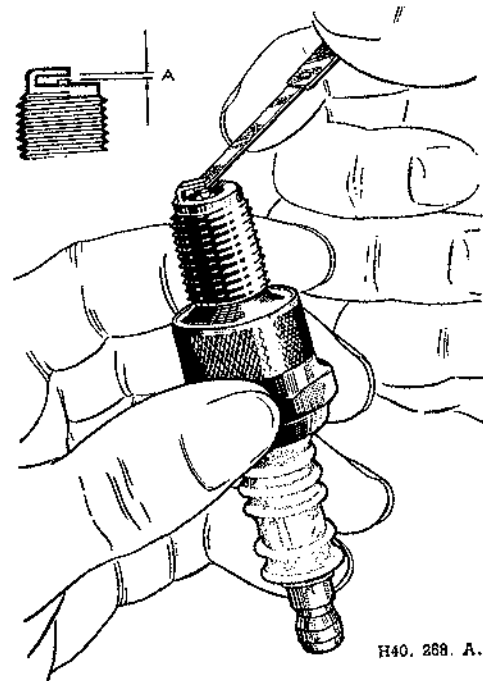

Fig. B.7. Checking sparking plug gap.

**Section B.9**

**FAULT DIAGNOSIS**

Symptom	No.	Possible Fault
(a) Engine will not fire	1	Battery discharged
	2	Distributor contact points dirty, pitted or out of adjustment
	3	Distributor cover "tracked" or cracked
	4	Distributor carbon brush not in contact with cover
	5	Loose connection in low-tension circuit
	6	Distributor rotor arm cracked
	7	Coil faulty

# B

## IGNITION SYSTEM

Symptom	No.	Possible Fault
(b) Engine misfires	1	Distributor contact points dirty, pitted or out of adjustment
	2	Contact breaker spring weak
	3	Distributor cover "tracked" or cracked
	4	Coil faulty
	5	Loose connection in low-tension circuit
	6	High-tension cables cracked or perished
	7	Sparking plug loose
	8	Sparking plug insulation cracked
	9	Sparking plug gap incorrect
	10	Ignition timing too far advanced

### MODIFICATION REFERENCES

<i>Service Reference Number</i>	<i>Date</i>	<i>Subject</i>	<i>Details of Changes</i>

# **SECTION C**

## **COOLING SYSTEM**

Section No. C.1	Description
Section No. C.2	Adjustments in vehicle
Section No. C.3	Radiator
Section No. C.4	Thermostat
Section No. C.5	Temperature gauge
Section No. C.6	Fan and pump assembly
Section No. C.7	Draining and flushing the system
Section No. C.8	Frost precautions
Section No. C.9	Fault diagnosis

---





## Section C.1

### DESCRIPTION

The circulation of the cooling water is effected by a centrifugal pump mounted in front of the cylinder block and driven by a belt from the crankshaft pulley. A thermostat is fitted in the water outlet pipe at the front end of the engine.

When filling or topping-up the radiator, do so when the engine is cold, and if possible use rain water or clean soft water. Fill up to the filler plug orifice.

The capacity of the system is 20 pints (24 U.S. pints; 10.8 litres).

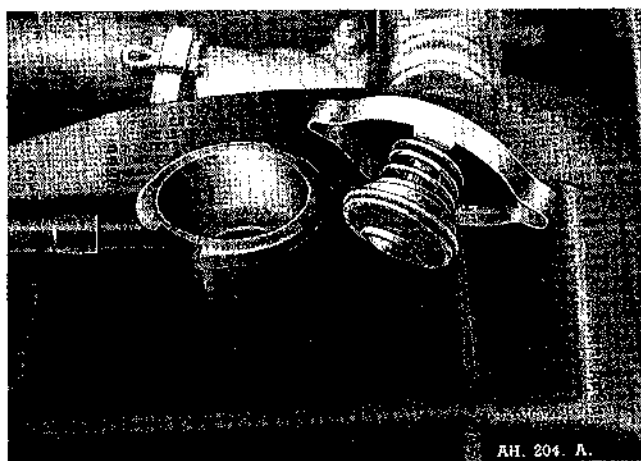

Fig. C.1. Showing the radiator filler with its cap removed.

## Section C.2

### ADJUSTMENTS IN VEHICLE

Overheating may be caused by a slack fan belt, excessive carbon deposit in the cylinders, running with the ignition too far retarded, improper carburetter adjustment, a partially choked radiator causing failure of the water to circulate, or loss of water due to leakage or evaporation.

The belt should be just sufficiently tight to prevent slip, yet it should be possible to move it laterally about 1 in. (2.54 cm.). To make an adjustment, slacken the bolts 1 and 4, fig. C.2, which hold the generator in position, then raise or lower the generator until the desired tension of the belt is obtained. Securely lock the generator in position again at securing points 1 and 4, fig. C.2, when the adjustment has been made. It must be understood that there is a correct and incorrect method of fitting fan blades. The blades are not flat, but shaped, and the concave or hollow side should be the leading one, thus, when fitting to an engine the convex or arched side must always face the radiator. This convex side is further easily identified as stiffeners are pressed into the blades; they project on this convex face.

In cases of overheating, the position of the fan blades should at once be examined; make sure, after dismantling, that the fan is fitted the right way round.

## Section C.3

### RADIATOR

#### To Remove

- (1) Drain the cooling system.
- (2) Slacken the hose clip, on the upper water hose, at the thermostat housing and with the aid of a screwdriver ease the pipe off the housing extension.
- (3) Take off the radiator bottom hose by releasing the clips on the water pump and the heater outlet pipe.
- (4) Disconnect the thermometer element from the radiator header tank.
- (5) Take off the six nuts (three on each side) which secure the radiator to the mounting flanges and remove the radiator.
- (6) Inspect the radiator core for damage and test it for water leaks. Solder at the points where leakage occurs or renew the core if necessary.
- (7) Inspect the flexible mountings for wear.
- (8) Inspect the drain tap for leaks and renew it if necessary.
- (9) Test the filler cap.
- (10) Inspect the hose connections for deterioration and renew them if necessary.

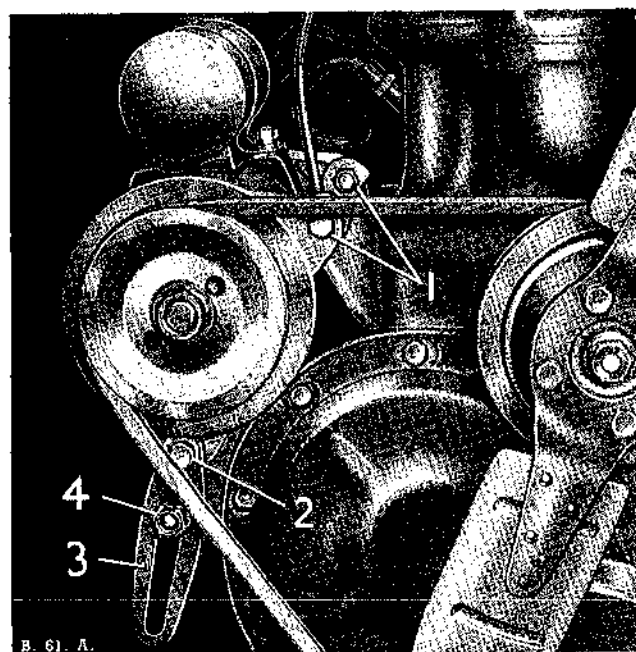

Fig. C.2. Fan belt adjustment.  
1 and 2. Generator securing bolts.  
3. Swinging link. 4. Locknut.

# C

## COOLING SYSTEM

### To Replace

Installation is a reversal of the procedure "To remove".

### Section C.4

#### THERMOSTAT

#### To Remove

- (1) Drain the cooling system (see Section C.7).
- (2) Disconnect the water outlet hose from the outlet elbow.
- (3) Remove the two nuts securing the outlet elbow to the cylinder head and lift off the outlet elbow.
- (4) Remove the outlet elbow to cylinder head joint.
- (5) Lift out the thermostat, fig. C.3.
- (6) Test the thermostat opening temperature by immersing it in water at a temperature between 158° and 167° F. (70° and 75° C.). If the thermostat valve does not start to open, or the valve sticks in the fully open position, the thermostat should be renewed. No attempt should be made to repair the thermostat.
- (7) Clean the joint faces at the outlet elbow and at the housing in the cylinder head.

#### To Replace

The installation of the thermostat is a reversal of the procedure "To remove". Fit a new joint gasket between the outlet elbow and the cylinder head. In an emergency the engine can be run with the thermostat removed.

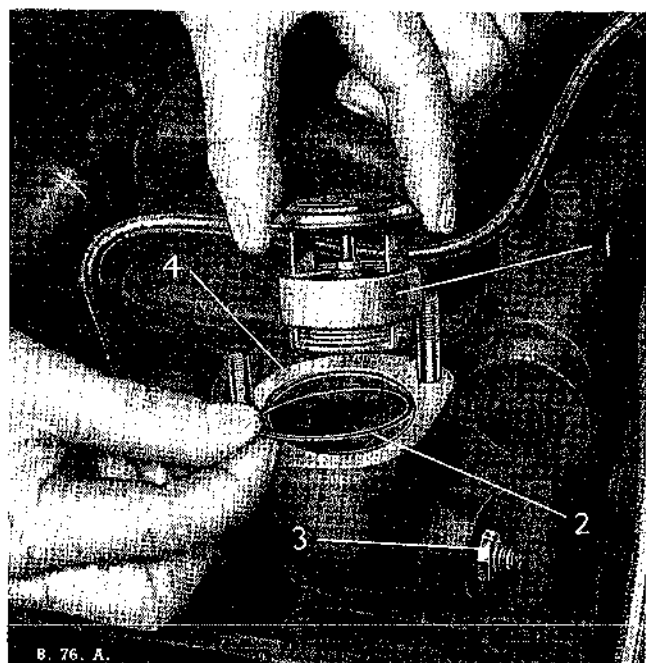

Fig. C.3. Illustrating the removal of the thermostat from its housing.  
1. Thermostat. 2. Joint washer.  
3. Temperature gauge connection. 4. Thermostat housing.  
(Not applicable to this installation).

### Section C.5

#### TEMPERATURE GAUGE

A temperature gauge unit, consisting of a thermal element and dial indicator is fitted to the vehicle. The thermal element is held in the radiator header tank by a gland nut. The dial indicator is situated in the instrument panel and is connected to the element by a capillary tube filled with mercury.

Damage to any of the above mentioned parts will necessitate the renewal of the complete temperature gauge unit.

### Section C.6

#### FAN AND PUMP ASSEMBLY

#### To Remove

- (1) Remove the radiator (see Section C.3).
- (2) Remove the generator (see Section N).
- (3) Unscrew the four set bolts securing the water pump to the crankcase. Withdraw the fan and pump assembly and remove the fan belt.

#### To Dismantle

- (1) Remove the four set bolts and withdraw the fan blades from the pulley.
- (2) Remove the nut and washers from the pump spindle and withdraw the pulley and hub which is keyed to the spindle.
- (3) Remove the key and tap the spindle rearwards, complete with the impeller.
- (4) Remove the front bearing circlip and withdraw the dished grease retainer.
- (5) Remove the rubber water seal assembly and its distance-piece from the rear of the housing.
- (6) Drift out the front bearing using Tool No. 18G-61; the bearing distance-piece will follow.
- (7) To remove the rear bearing, place the dummy bearing of Tool No. 18G-61 in the pump body, and the drift, which is piloted in the rear bearing, is screwed into it. Tap the complete assembly out through the housing of the front bearing.
- (8) Withdraw the felt grease seal and retainer.
- (9) Clean all the dismantled pump parts.
- (10) Inspect the spindle for wear.
- (11) Inspect the seals for damage and wear. It is advisable to install new seals whenever the pump has been dismantled.
- (12) Inspect the bearings for pits and scores. They should be renewed if evidence of excessive wear is detected. Coat the bearings with engine oil and wrap them in a clean cloth or paper until required for reassembly.

## COOLING SYSTEM

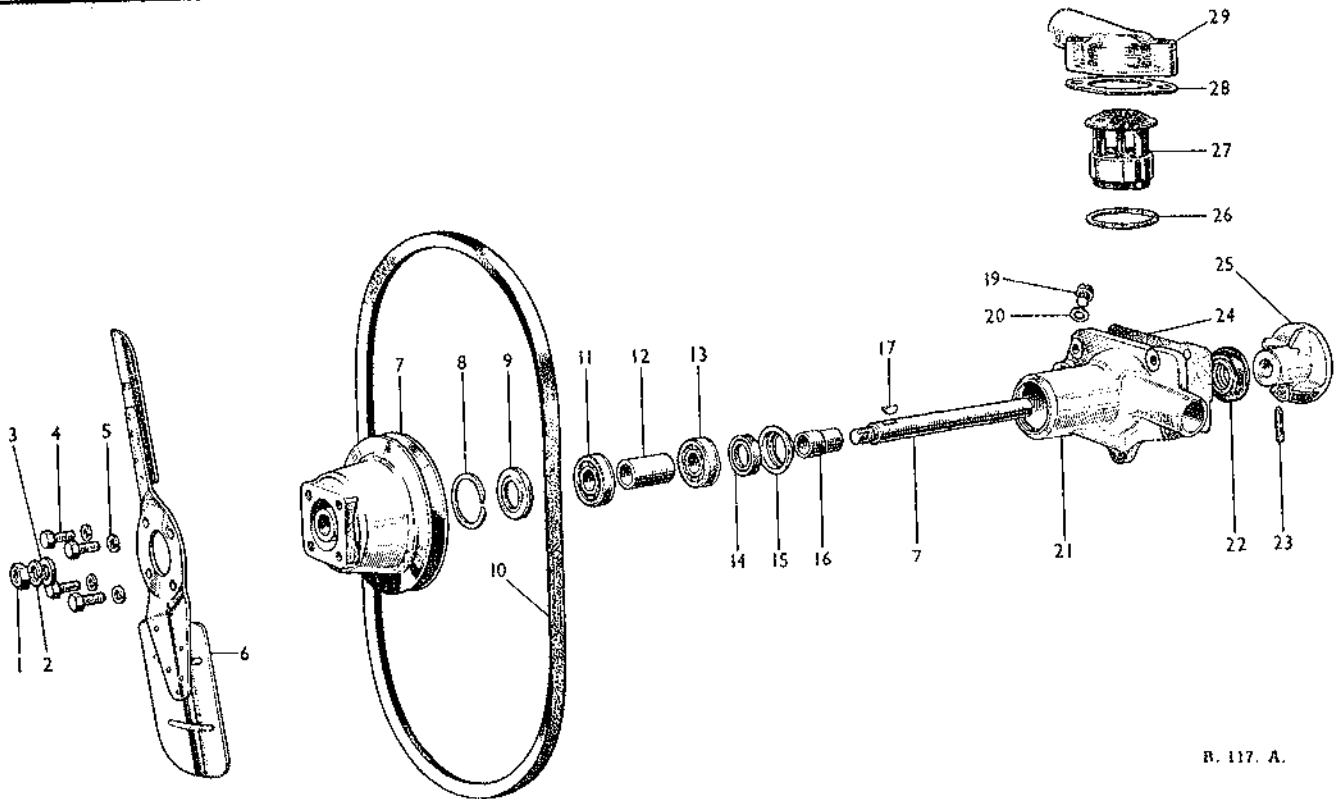

R. 117. A.

Fig. C.4. The water pump exploded.

- |                       |                     |                       |
|-----------------------|---------------------|-----------------------|
| 1. Spindle nut.       | 11. Ball race.      | 20. Fibre washer.     |
| 2. Spring washer.     | 12. Distance piece. | 21. Pump body.        |
| 3. Plain washer.      | 13. Ball race.      | 22. Water seal.       |
| 4. Fan blade setpins. | 14. Rubber seal.    | 23. Locking pin.      |
| 5. Spring washer.     | 15. Seal housing.   | 24. Joint washer.     |
| 6. Fan.               | 16. Distance piece. | 25. Impeller.         |
| 7. Fan pulley.        | 17. Key.            | 26. Joint washer.     |
| 8. Split ring.        | 18. Spindle.        | 27. Thermostat.       |
| 9. Grease retainer.   | 19. Oiling plug.    | 28. Joint washer.     |
| 10. Fan belt.         |                     | 29. Thermostat cover. |

- (13) If the bearings do not fit properly on the pump spindle or in the body, renew the parts as required.
- (14) Inspect the fan belt for uneven wear or frayed fabric, and renew the belt if required.

**To Reassemble**

Reassembly of the fan and pump is a reversal of the procedure "To dismantle". Particular note should be made of the following :—

- (1) Pack the bearings with the recommended grade of grease during assembly.
- (2) To install the bearings, assemble Tool No. 18G-61, and drive the rear bearing into its housing. The front bearing and distance piece are fitted in a similar manner.
- (3) Refit the fan blades to the pulley with the radiused tips of the blades leading.
- (4) Check to see that the bearings run freely without excessive end play, by spinning the fan.

**To Replace**

The installation of the fan and pump assembly is a reversal of the procedure "To remove". Particular note should be made of the following :—

- (1) Install a new joint gasket between the pump body and the cylinder block.
- (2) Adjust the fan belt (see Section C.2).
- (3) Apply the grease gun.

**Section C.7****DRAINING AND FLUSHING THE SYSTEM****To Drain the System**

When the vehicle is to be stored, the entire cooling system should be drained to protect against corrosion and, in certain instances, freezing. To drain the system proceed as follows :—

- (1) With the vehicle standing on level ground, remove the radiator filler cap.

# C

## COOLING SYSTEM

**Caution.**—As the system is pressurised, do not remove the radiator filler cap while the engine is running and always wait until the water has cooled.

If it is necessary to remove the filler cap while the engine is hot it is essential to remove it gradually, and the filler neck is provided with a shaped cam to enable this to be done.

Unscrew the cap slowly until the retaining tongues are felt to engage the small lobes at the end of the filler neck cam, and wait until the pressure in the radiator is fully released before finally removing the cap.

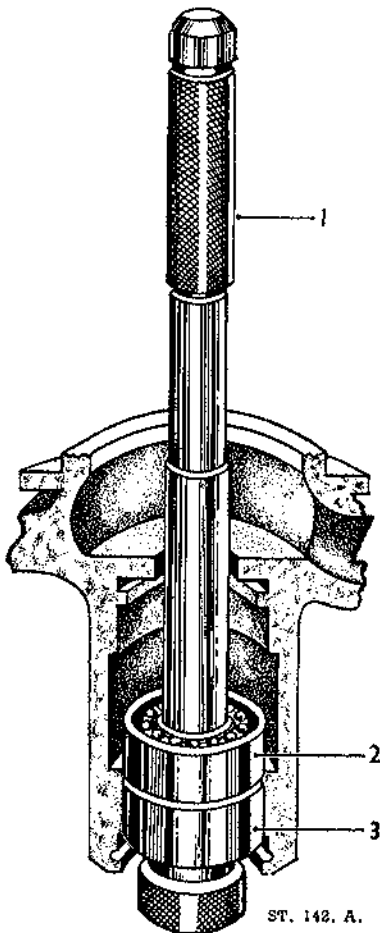

ST. 142. A.

Fig. C.5. Removing rear bearing with service tool 18G 61.

1. Drift. 2. Rear bearing. 3. Dummy bearing.

- (2) Open the cylinder block and radiator drain taps. If the system contains anti-freeze mixture it should be drained into clean containers, strained and preserved for re-use.
- (3) Insert a length of wire into the open taps to disturb any sediment, etc., that may block the flow.

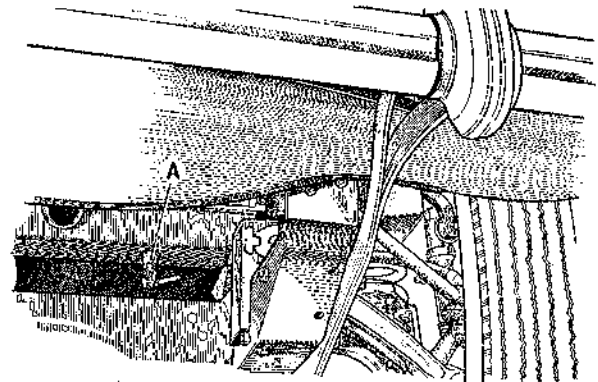

AH. 24. A.

Fig. C.6. Showing the radiator drain tap A in the open position. Turn the tap lever down to close.

- (4) To prevent the possibility of operating the vehicle with the system drained, make sure that a suitable notice is placed on the vehicle, or other suitable precautions taken.

### To Flush the System

If an inhibitor is not used, the cooling system should be drained, cleaned and flushed at intervals depending upon the type of vehicle operation and the local water conditions. Do not use strong caustic or acid solutions for cleaning purposes because they have a detrimental effect on various parts of the system. To clean and flush the system, proceed as follows :—

- (1) Drain the system completely as described above.
- (2) With a hose pipe, or fresh quantities of clean water, flush the system through until water issuing from the drain taps appears to be clean.

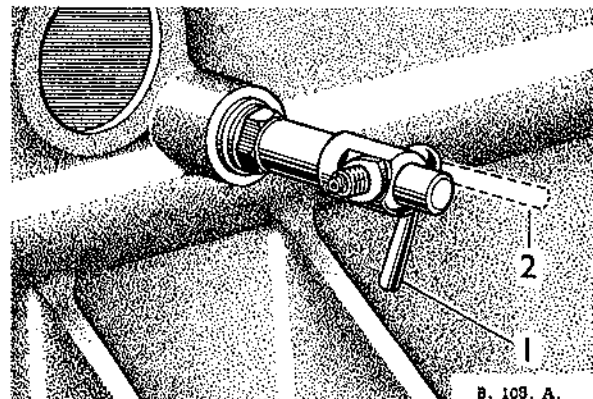

B. 109. A.

Fig. C.7. Showing the cylinder block drain tap in:—  
1. Closed position. 2. Open position.

- (3) Allow the system to drain completely, then close the drain taps.
- (4) Fill the system with clean water (or anti-freeze solution), slowly, to allow air to escape past the thermostat valve, up to the bottom of the filler neck.
- (5) Replace the filler cap by turning it approximately 90° in a clockwise direction.

## Section C.8

### FROST PRECAUTIONS

Care should be taken to see that the water is drained off completely, for in case of freezing it will do harm by expansion taking place, and fracture of the cylinder block may result. There are two drain taps, one of them on the right-hand side of the cylinder block, and the other at the base of the radiator. Both taps must be opened to drain the system and the vehicle must be on level ground while draining.

Freezing may occur first at the bottom of the radiator or in the lower hose connection. Ice in the hose will stop water circulation, and may cause boiling.

A muff can be used to advantage, but care must be taken not to run with the muff fully closed, or boiling will result.

#### Protection by Use of Anti-Freeze Mixture

When frost is expected or when the vehicle is to be used in very low temperatures, make sure that the strength of the solution is, in fact, up to the strength recommended by the manufacturers, for the conditions likely to be encountered.

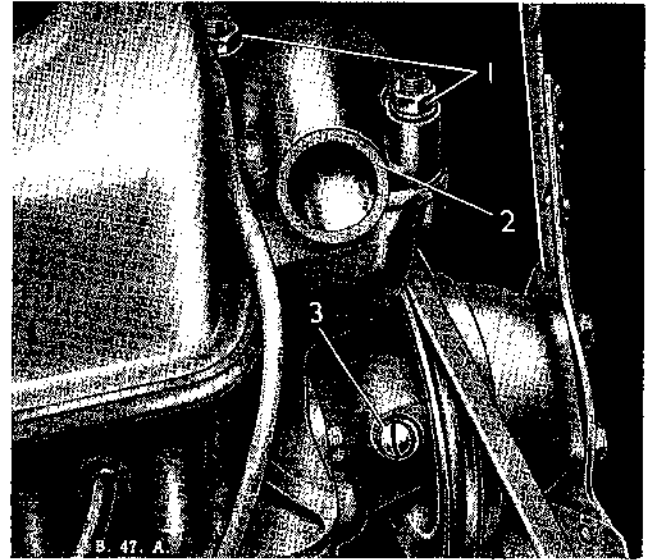

*Fig. C.8. Showing location of the oiling plug on the water pump body.*  
 1. Thermostat cover bolts.      2. Thermostat outlet.  
 3. Water pump oiling plug.

The strength of the solution must be maintained by topping-up with anti-freeze solution as necessary. Excessive topping-up with water will reduce the degree of protection afforded.

The following brands of Anti-freeze are officially recommended :

- (1) Smith's "Bluecol."
- (2) Shell "Snowflake".
- (3) Esso Anti-freeze.

If the cooling system has to be emptied, run the mixture into a clean container and use it again.

## Section C.9

### FAULT DIAGNOSIS

Symptom	No.	Possible Fault
(a) Internal Water Leakage	1	Cracked cylinder wall
	2	Loose cylinder head nuts
	3	Cracked cylinder head
	4	Faulty gasket
	5	Cracked tappet chest wall

# C

## COOLING SYSTEM

Symptom	No.	Possible Fault
<b>(b) Poor Circulation</b>	1	Radiator core blockage
	2	Water jacket restriction
	3	Low water level
	4	Loose fan belt
	5	Defective thermostat
	6	Perished or collapsed radiator bottom hose
<b>(c) Corrosion</b>	1	Impurities in water
	2	Infrequent draining and flushing
<b>(d) Overheating</b>		In (b) check 1, 2, 3, 4, 5 and 6
	1	Sludge in crankcase
	2	Faulty ignition timing
	3	Low oil level in sump
	4	Tight engine
	5	Choked exhaust system
	6	Binding brakes
	7	Slipping clutch
	8	Valve timing incorrect
	9	Retarded ignition
10	Mixture too weak	







# **SECTION D**

## **FUEL SYSTEM**

Section No. D.1	The fuel tank
Section No. D.2	Fuel pump
Section No. D.3	Servicing the pump
Section No. D.4	Fuel pump adjustment
Section No. D.5	Tracing pump troubles
Section No. D.6	Fuel pump maintenance
Section No. D.7	The carburetters
Section No. D.8	Carburetter adjustment
Section No. D.9	Sources of carburetter trouble
Section No. D.10	The air cleaners
Section No. D.11	Fault diagnosis

---



## Section D.1

### THE FUEL TANK

- (1) Remove the drain plug from the tank and drain the petrol into a suitable receptacle.
- (2) Within the luggage compartment release and remove the spare wheel by disconnecting its securing strap.
- (3) Remove the carpet which covers the floor of the luggage compartment.
- (4) Remove the petrol tank feed pipe cover, situated in the top right-hand corner of the boot, by unscrewing the six securing Phillip screws. Disconnect the feed pipe from the tank.
- (5) Disconnect the petrol tank filler pipe at its union with the tank. The union is made by a rubber joint hose and two securing clips.
- (6) Detach the insulated lead from the petrol gauge unit terminal.
- (7) Release the tank securing straps by unscrewing the nut and locknut of each tank strap stud. These nuts are visible on the underside of the luggage compartment floor just in front of the rear body panel. Pull the straps through the compartment floor and hinge them back on their clevis pin anchorages.
- (8) Lift out the tank.

1. Outlet union.
2. Fibre washer (thick, orange).
3. Spring clip.
4. Delivery valve disc.
5. Valve cage.
6. Fibre washer.
7. Suction valve disc.
8. Pump body.
9. Diaphragm assembly.
10. Armature guide rollers.

11. Retaining plate.
12. Filter.
13. Fibre washer (thick, orange)
14. Filter plug.
15. Steel armature.
16. Push rod.
17. Magnet iron core.
18. Magnet coil.
19. Rocker hinge pin.
20. Terminal screw.

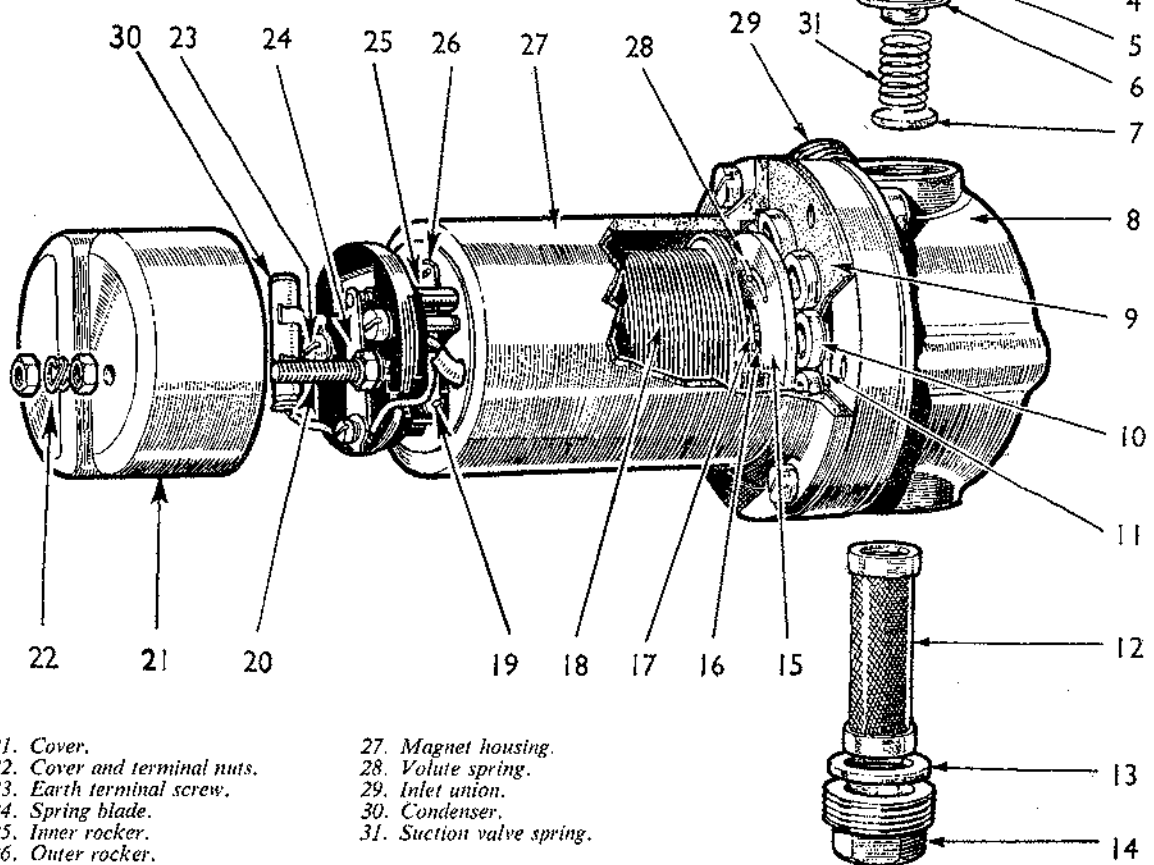

21. Cover.
22. Cover and terminal nuts.
23. Earth terminal screw.
24. Spring blade.
25. Inner rocker.
26. Outer rocker.

27. Magnet housing.
28. Volute spring.
29. Inlet union.
30. Condenser.
31. Suction valve spring.

Fig. D.1. Lift pump--components.

# D

## FUEL SYSTEM

### Section D.2

#### FUEL PUMP

##### Description

The fuel pump is an S.U. type H.P., 12-volt electric pump. (See Fig. D.1).

The pump consists of three main assemblies, the body, the magnet assembly and the contact breaker.

The body is composed of a hollow alloy die-casting (8) in two parts, into the bottom of which the filter (12) is screwed. The pump inlet union (29) is screwed in at an angle on one side. The outlet union (1) is screwed into the top and tightens down on the delivery valve cage (5) which is clamped between the two fibre washers (2) and (6). In the top of the delivery cage is the delivery valve, a thin brass disc (4) held in position by a spring clip (3). Inserted in the bottom of the cage is the suction valve (7), being a similar disc to (4) and held lightly on a seating machined in the body by a spring. Holes connect the space between the valves and the pumping chamber, a shallow depression on the forward face of the body. This space is closed by a diaphragm assembly (9) clamped at its outside edge between the magnet housing (27) and body (8) and at its centre between the retaining plate and the steel armature (15). A bronze rod to which the diaphragm is attached (16) is screwed through the centre of the armature, passes through the magnet core to the contact breaker, located at the other end. A volute spring (28) is interposed between the armature and the end plate of the coil to return the armature and diaphragm.

The magnet housing consists of a cast-iron pot containing an iron core (17), wound with a coil of copper wire to energise the magnet. Between the magnet housing and the armature are fitted eleven spherical-edged brass rollers (10). These locate the armature centrally within the magnet at all times, and allow absolute freedom of movement in a longitudinal direction. The contact breaker consists of a small bakelite moulding carrying two rockers (25) and (26), which are both hinged to the moulding at one end and are connected together at the top end by two small springs, arranged to give a "throw over" action. A trunnion is fitted into the centre of the inner rocker, and the bronze push-rod (16) connected to the armature is screwed into this. The outer rocker (26) is fitted with a tungsten point, which makes contact with a further tungsten point on a spring blade (24). This spring blade is connected to one end of the coil, and the other end of the coil is connected to the terminal (20).

A short length of flexible wire is connected to the outer rocker and to the other terminal (23) which also serves to hold the bakelite moulding on the magnet housing.

The rocker mechanism is insulated by fibre bushes. Two fibre bushes are fitted to one of the spindles of the "throw over" mechanism in order to silence the operation of the contact breaker.

##### Action of the Fuel Pump

When the pump is at rest, the outer rocker lies in the outer position and the tungsten points are in contact. The current passes from the terminal through the coil back to the blade, through the points and to the earth return, thus energising the magnet and attracting the armature. This comes forward, bringing the diaphragm with it and sucking petrol (gasoline) through the suction valve into the pumping chamber. When the armature has advanced nearly to the end of its stroke the "throw over" mechanism operates, and the outer rocker flies back, separating the points and breaking the circuit. The spring (28) then pushes the armature and diaphragm back, forcing petrol (gasoline) through the delivery valve at a rate determined by the requirements of the engine. As soon as the armature gets near the end of this stroke the "throw over" mechanism again operates, the points again make contact, and the cycle of operations is repeated.

### Section D.3

#### SERVICING THE PUMP

When a pump comes in for reconditioning, the first thing to do is to determine, by the sense of smell, whether the parts in contact with the fuel have become coated with gum. The gum is a substance similar to varnish and can cause the eventual destruction of the diaphragm. Its presence can be detected by smelling the outlet union: if an unpleasant stale smell is noticed, gum is present. The ordinary smell of petrol (gasoline) denotes that no gum has been formed.

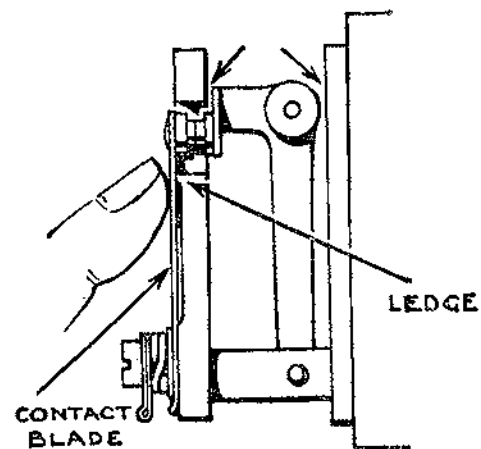

Fig. D.2.  
The correct armature setting.

## To Dismantle the Pump

- (1) Unscrew the filter plug and remove the plug, washer and filter. The latter may be found clogged with gum.
- (2) Remove the inlet union and washer.
- (3) Remove the outlet union and its washer.
- (4) Extract the valve cage, valve cage washer, suction valve and spring. Remove the circlip retaining the delivery valve and withdraw the valve disc.
- (5) Unscrew the six screws holding the two main components of the pump together. If the presence of gum has been detected, all parts (NOT ALUMINIUM) must be boiled in 20 per cent. caustic soda solution, dipped in nitric acid and then washed in boiling water. Aluminium parts must be cleaned by thoroughly soaking in methylated spirits.
- (6) If no evidence of gum formation has been found, separate the two parts of the pump and check the action of the valves. It should be possible to blow freely but not to suck air back through the inlet union, and to suck, but not blow, air through the delivery valve. If valve action is satisfactory there is no need to disturb their assembly.
- (7) Clean the filter with a brush and swill out the body of the pump.
- (8) Unscrew the diaphragm assembly from its trunnion in the contact breaker by rotating the whole assembly in an anti-clockwise direction. Take care not to lose the rollers fitted behind the diaphragm.
- (9) Remove the contact breaker cover and the nut on the terminal acting as a seating for the cover. Cut away the lead washer squeezed on the terminal threads below the nut, and push the terminal down a short way so that the tag on the coil end is free on the terminal.
- (10) Unscrew the contact blade retaining screw and the two long pedestal screws; remove the blade and the pedestal. Do not damage the coil end in disengaging the tag from the terminal.
- (11) Push out the rocker hinge pin.  
Do not disturb the core of the magnet: special press tools are required for its correct location.

## To Reassemble the Pump

- (1) Make sure that all parts are clean.
- (2) Fit each valve with its smooth side downwards and ensure the correct location of the circlip in its groove.
- (3) Fit the red fibre washers as follows: the thin one below the valve cage, the next thickest above the cage, and the thickest on the inlet union. The washer on the filter plug is also a thick red fibre one.

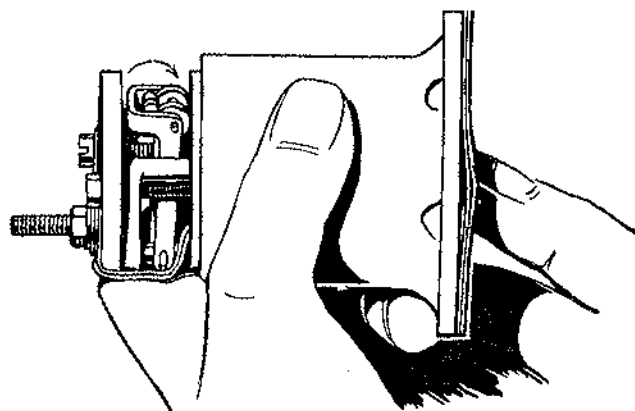

Fig. D.3. Checking the armature setting.

- (4) Assemble the contact breaker on its pedestal so that the rockers are free in their mountings without appreciable sideplay. Any excessive sideplay on the outer rocker allows the points to be out of line, while excessive tightness interferes with the action of the pump through sluggish contact breaker operation.
- (5) In cases of tightness it may be necessary to square up the outer rocker with a pair of thin-nosed pliers.
- (6) The hinge pin is case hardened and ordinary wire must never be used as a replacement.
- (7) If the contact blade has been removed, replace it underneath the tag, bearing directly against the pedestal. When the points are separated, the blade should rest against the ledge of the pedestal and must not be so stiff as to prevent the outer rocker from coming right forward when the points are in contact. The points must make contact when the rocker is in the midway position. To check, hold the blade in contact with the pedestal without pressing on the overhanging portion, and test the gap between the white rollers and the body of the pump with a .030 in. (.76 mm.). If necessary, set the tip of the blade to give the correct clearance.

**Note.**—Fit the spring washer on the earth connection screw between the tag and the pedestal as the spring washer is not a reliable conductor and the tag must bear directly against the head of the screw.

Solder the coil ends to their tags and the two terminals to the earthing wire.

The assembly of components on the terminal screw holding the cover in position is as follows: spring washer, wiring tag, lead washer and recessed nut. In no circumstances omit the spring washer or shorten the assembly in any way or the pedestal may be broken when the cover retaining nut is tightened.

Fit the armature return spring with its larger diameter towards the coil and the smaller to the armature. Do not stretch the spring.

# D

## FUEL SYSTEM

### Section D.4

#### FUEL PUMP ADJUSTMENT

If the armature has been removed, reassemble and adjust as follows :—

- (1) Swing the contact blade on the pedestal to one side.
- (2) Fit the impact washer to the armature recess.
- (3) Screw the armature into position.
- (4) Place the eleven guide rollers in position around the armature. Use no jointing compound on the diaphragm.
- (5) Hold the magnet assembly in an approximately horizontal position and push in the armature firmly and steadily. If the contact breaker throws over, screw the armature farther in until it ceases to do so; unscrew the armature one-sixth of a turn at a time until a position is found where the rocker just throws over. It is important to press steadily and not to jerk the armature. When the correct position is found unscrew the armature a further two-thirds of a turn; this is important.

When a new diaphragm is fitted it is probable that considerable pressure will be needed to push the armature right home. If there is any doubt

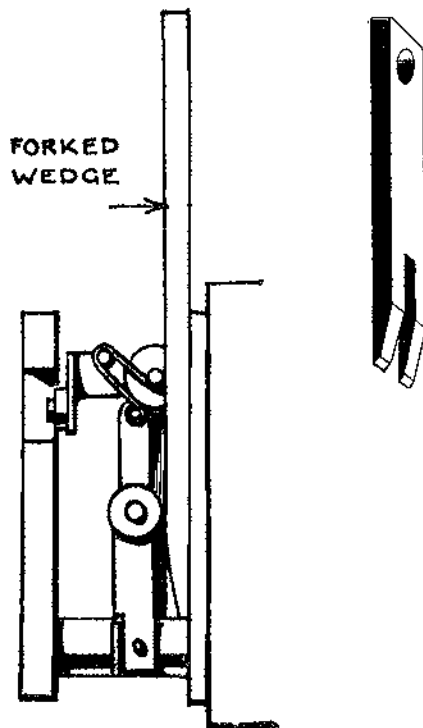

Fig. D.4. The use of a forked wedge is necessary to stretch the pump diaphragm to its outermost position.

concerning the point at which the contact breaker throws over, turn it back one-sixth of a turn.

- (6) Place the magnet housing in position on the main body with the drain hole at the bottom; make sure that the rollers are still in their correct positions. If a roller drops it may get trapped between the two ports and cut a hole in the diaphragm.

Insert the coupling screws and the earth terminal screw. Do not screw up tightly before stretching the diaphragm to its outermost position. This is best accomplished by the use of a wedge as shown in Fig. D.4. Insert the wedge between the white rollers of the outer rocker and pressed under the tips of the inner rocker until it lifts the trunnion in the centre of the inner rocker as far as it will go.

If no wedge is available, insert a matchstick under one of the white rollers and pass a current through the pump. This will excite the magnet, actuate the armature and stretch the diaphragm: the screws may then be tightened down fully while the diaphragm is held in this position. The spring blade rests against a small projection on the bakelite moulding, and it must be set so that when the points are in contact it is deflected back from the moulding. The width of the gap at the points is approximately .030 in. (.76 mm.).

- (7) Now place the pump on test, using a cut-away cover to allow observation of the contact breaker and prevent the hinge pin from falling out.

A test rig of the type illustrated in Fig. D.5 is advised and either petrol (gasoline) or paraffin (kerosene) may be used for testing.

When the pump is switched on it should prime itself promptly and if there is any air leak in the pump or in its connections, bubbles will be seen coming out of the pipe projecting into the flow-meter. Bubbles normally appear when the pump is first started up but should cease to appear when the pump has been running for a minute or two.

Turn off the tap fully; the pump should stand without repeating its action for at least 15 seconds, if not, the suction valve is not seating correctly.

Next, turn the tap off slowly and note whether the pump idles satisfactorily, and that the outer rocker comes fully forward and contacts the pedestal. While in this position, press the tip of the blade inwards to reduce the stroke of the pump gradually. However much the stroke is reduced the pump should continue to pump normally until it fails, when there is no gap left. If it buzzes instead of pumping, the cause is usually excessive flexibility in the diaphragm, and is unlikely to occur on a new one.

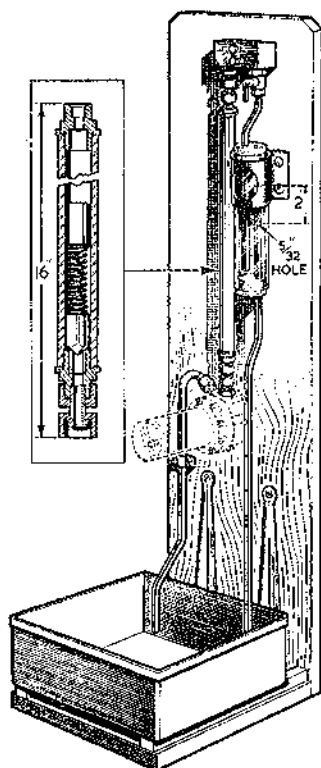

Fig. D.5.  
A test rig for the fuel pump.

Finally test the pump on 9 volts, when it should work satisfactorily though probably with a somewhat reduced output.

**Note.**—Three important points, which will seriously affect the working of the pump if overlooked, are the following :—

- (1) Keep the contact breaker blade out of contact while setting the diaphragm.
- (2) Press firmly without jerking on the diaphragm.
- (3) Stretch the diaphragm to its limit while tightening up the body screws.

## Section D.5

### TRACING PUMP TROUBLES

Should the pump cease to function, first disconnect the fuel delivery pipe from the pump. If the pump then works the most likely cause of the trouble is sticking needles in the float-chambers of the carburetters. Should the pump not work, disconnect the lead from the terminal and strike it against the body of the pump after switching on the ignition. If a spark occurs it indicates that the necessary current is available at the terminals, and that the trouble arises with the pump mechanism. If no spark can be detected, then it is an indication that the current supply has failed and that attention should be

given to the wiring and battery. If current is present further investigation should be carried out by removing the bakelite cover which is retained by the terminal nut. Touch the terminal with the lead. If the pump does not operate and the contact points are in contact yet no spark can be struck off the terminal, it is very probable that the contact points are dirty and require cleaning. These may be cleaned by inserting a piece of card between them, pinching them together and sliding the card backwards and forwards.

If, when the wire is connected to the terminal and the tickler of the carburetter is depressed, the points fail to break, it is possible that there is either an obstruction in the suction pipe, which should be cleared by blowing it through with air, or some irregularity in the pump itself is preventing the correct movement. This may be due either to the diaphragm having stiffened, or to foreign matter in the roller assembly which supports the diaphragm, in which case the diaphragm should be removed and the whole assembly cleaned and reassembled in accordance with the instructions on page D.3.

On the other hand, if the points are not making contact, see that the tips of the inner rocker (25) (Fig. B.1) are in contact with the magnet housing. If they are not, it is an indication that the armature has failed to return to the end of its normal travel.

To cure this, loosen the six screws which attach the magnet housing to the pump body, and make sure that the diaphragm is not sticking to the face of the magnet housing by carefully passing a penknife between the two. The hinge pin (19) should then be removed and the six retaining screws tightened up again. The tips of the inner rockers will probably now be found to be making contact with the face of the magnet housing, but if they are not, it will be necessary to remove and dismantle the whole magnet assembly in order to ascertain if an accumulation of foreign matter has caused a jam. Remember that whenever the magnet housing is removed, care should be taken to see that the guide rollers (10) do not drop out.

### Pump Noisy

If the pump becomes noisy and works rapidly, it is usually an indication that there is an air leak on the suction side of the pump. Check the level of the fuel in the tank and see that it is not too low.

The simplest way to test for air leakage is to disconnect the fuel pipe from the carburetter and place its end in a glass jar (approximately 1 pint or half a litre) and allow the pump to deliver fuel into it. If air bubbles appear when the end of the pipe has become submerged in the fuel, it is a clear indication of an air leak on the suction side of the pump in the fuel feed pipe between the tank and the pump, which should be found and

# D

## FUEL SYSTEM

cured. Check all the unions and joints, making sure that the filter union and inlet unions are all quite airtight.

### Failure to Deliver Fuel

Should the pump continue beating without delivering fuel, it is probable that some dirt has become lodged under one of the valves, in which case they should be dismantled by unscrewing the top or delivery union and lifting out the valve cage, when they can be cleaned and reassembled. When replacing it, see that the thin hard red fibre washer is *below* the valve cage and the thick orange one above.

If the pump struggles to pump and becomes very hot, it is probable that the filter has become clogged or there is an obstruction on the suction side. The filter is readily removed for cleaning by unscrewing its retaining plug at the bottom of the pump.

## Section D.6

### FUEL PUMP MAINTENANCE

Apart from keeping the contacts clean and removing the filter at regular intervals for cleaning, there is no maintenance required on the fuel pump.

The filter can be removed by unscrewing the hexagon plug at the bottom of the pump, when it can be cleaned in petrol with a stiff brush. Never use rag to clean a filter.

Many of the troubles encountered with the pump are a result of the terminals not being tight, resulting in poor connections. Make sure that the earth wire terminal, in particular, is quite tight.

## Section D.7

### THE CARBURETTERS

The two S.U. carburetters are of the fixed-jet type, fitted with air cleaners.

A damper is provided in each carburetter, consisting of a plunger and non-return valve attached to the oil cap nut, and operates in the hollow piston rod which is partly filled with oil. Its function is to give a slightly enriched mixture on acceleration by controlling the rise of the piston and to prevent piston flutter.

## Section D.8

### CARBURETTER ADJUSTMENT

It is first essential to run the engine until it has attained its normal running temperature before commencing any mixture or slow-running adjustments.

The slow-running is governed by the setting of the jet adjusting screws and the throttle stop screws, all of which must be correctly set and synchronised if satisfactory results are to be obtained.

D.6

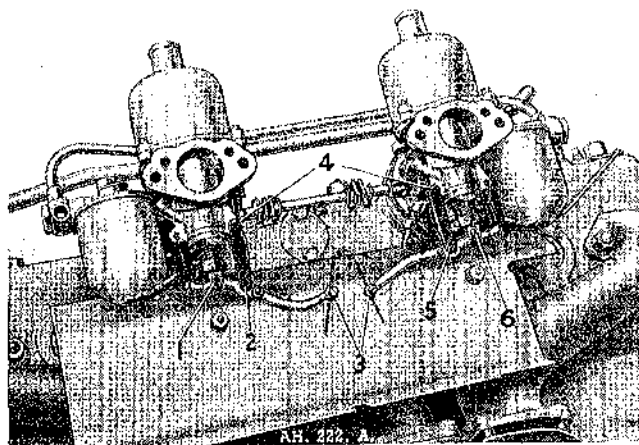

Fig. D.6. Throttle linkage oiling points. With an oil can lubricate the points indicated.

The two carburetter throttles are interconnected by a coupling shaft and spring coupling clips which enable them to be correctly synchronised when adjustments take place.

Before blaming the carburetter settings for bad slow-running, make quite sure that it is not due to badly set contact points, faulty plugs, bad valve clearance setting or faulty valves and valve springs.

Good slow-running cannot be obtained if the setting for the jets is incorrect. It is therefore advisable to commence any adjustments at this point.

In order to adjust the carburetters successfully it is necessary to remove the air cleaners and intake pipe assembly from the carburetters and engine valve cover and make sure the pistons work freely and the jets are properly centred (see below).

### Adjusting the Jets

- (1) Slacken off the pinch-bolt of one of the spring coupling clips locating the carburetter interconnecting shaft to the carburetter throttle spindles and also release the two screws securing the choke spring to the jet levers, so that each carburetter can be operated independently.
- (2) Release the throttle lever adjusting screws until both throttles are completely closed.
- (3) Turn the throttle lever adjusting screw for the rear carburetter clockwise until it is just touching the web on the carburetter body and then give it one full turn. This will set the rear carburetter for fast idling and leave the front one out of action. This can be ensured further by lifting the front carburetter piston a matter of  $\frac{1}{2}$  in. (13 mm.).



# FUEL SYSTEM

# D

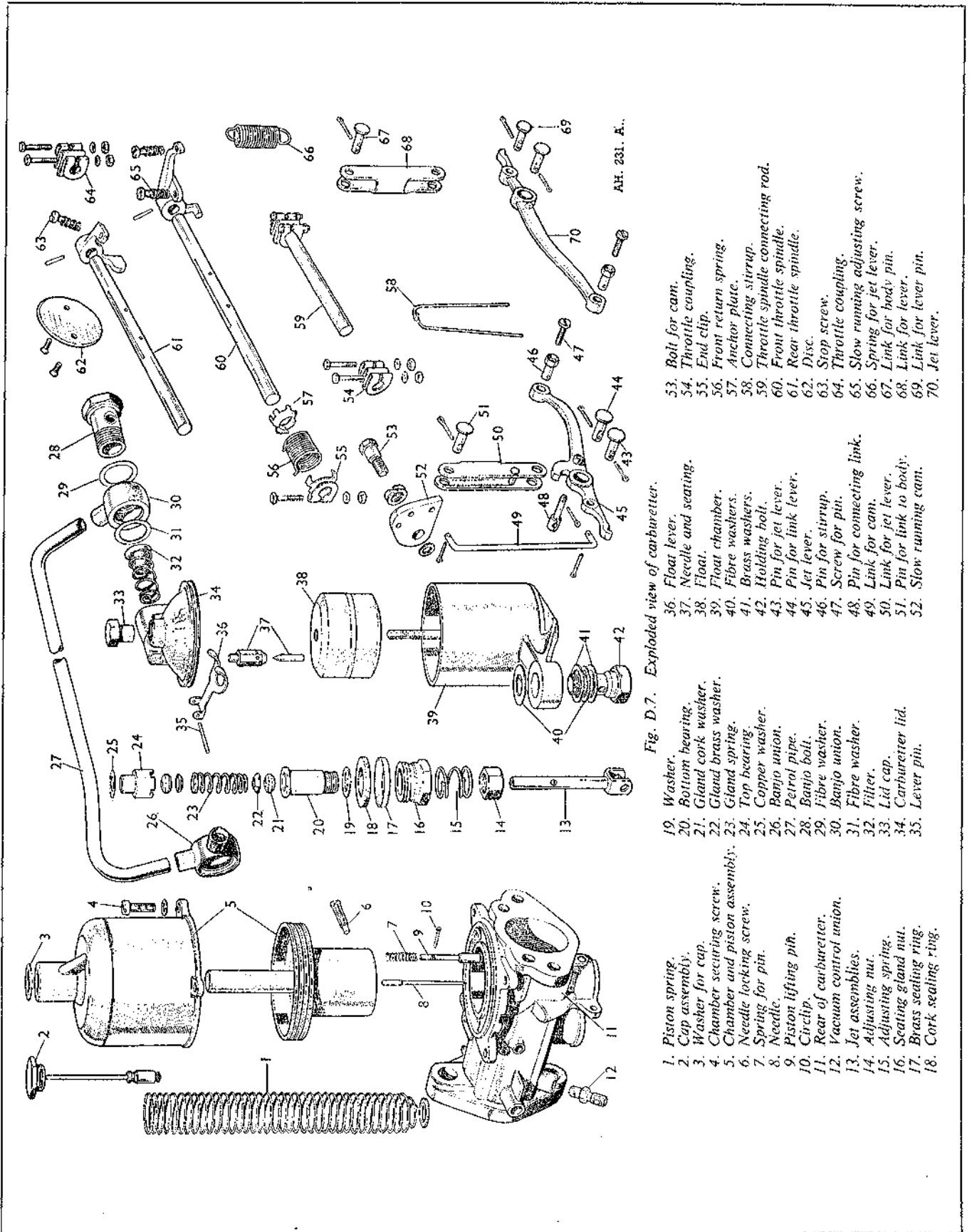

Fig. D.7. Exploded view of carburettor.

- 1. Piston spring.
- 2. Cap assembly.
- 3. Washer for cap.
- 4. Chamber securing screw.
- 5. Chamber and piston assembly.
- 6. Needle locking screw.
- 7. Spring for pin.
- 8. Needle.
- 9. Piston lifting pin.
- 10. Circlip.
- 11. Rear of carburettor.
- 12. Vacuum control union.
- 13. Jet assemblies.
- 14. Adjusting nut.
- 15. Seating gland nut.
- 16. Brass sealing ring.
- 17. Cork sealing ring.
- 18. Cork sealing ring.
- 19. Washer.
- 20. Bottom bearing.
- 21. Gland cork washer.
- 22. Gland brass washer.
- 23. Gland spring.
- 24. Top bearing.
- 25. Copper washer.
- 26. Petrol union.
- 27. Banjo union.
- 28. Banjo ball.
- 29. Fibre washer.
- 30. Banjo union.
- 31. Fibre washer.
- 32. Filter.
- 33. Lid cap.
- 34. Carburettor lid.
- 35. Lever pin.
- 36. Float lever.
- 37. Needle and seating.
- 38. Float.
- 39. Float chamber.
- 40. Fibre washers.
- 41. Brass washers.
- 42. Holding bolt.
- 43. Pin for jet lever.
- 44. Pin for link lever.
- 45. Jet lever.
- 46. Pin for stirrup.
- 47. Screw for pin.
- 48. Pin for connecting link.
- 49. Link for cam.
- 50. Link for jet lever.
- 51. Pin for link to body.
- 52. Slow running cam.
- 53. Bolt for cam.
- 54. Throttle coupling.
- 55. End clip.
- 56. Front return spring.
- 57. Anchor plate.
- 58. Connecting stirrup.
- 59. Throttle spindle connecting rod.
- 60. Front throttle spindle.
- 61. Rear throttle spindle.
- 62. Disc.
- 63. Stop screw.
- 64. Throttle coupling.
- 65. Slow running adjusting screw.
- 66. Spring for jet lever.
- 67. Link for body pin.
- 68. Link for lever.
- 69. Link for lever pin.
- 70. Jet lever.

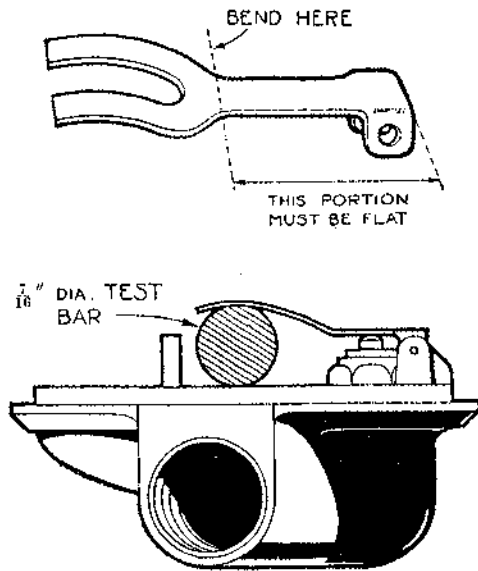

Fig. D.8. The correct setting of the float lever.

- (4) With the engine running, set the jet adjusting screw for the rear carburetter so that a mixture strength is obtained which will give the best running speed for this throttle opening, taking care to see that the jet head is kept in firm contact with the adjusting nut the whole time.
- (5) The correctness or otherwise of this setting can be checked by raising the suction piston with a small screwdriver, or similar instrument, to the extent of  $\frac{1}{32}$  in. (1 mm.). This should cause a very slight momentary increase in the engine speed without impairing the evenness of the running in any way.  
If this operation has the effect of stopping the engine it is an indication that the mixture setting is too weak.  
If an appreciable speed increase occurs and continues to occur when the piston is raised as much as  $\frac{1}{4}$  in. (6 mm.) it is an indication that the mixture is too rich.
- (6) When the rear carburetter mixture setting has been carried out correctly release its throttle adjusting screw so that it is clear of the stop and the throttle completely closed, and lift the piston  $\frac{1}{2}$  in. (13 mm.) to render it inoperative. Then repeat the jet-adjusting operations on the front carburetter.
- (7) When both carburetters are correctly adjusted individually for mixture strength the throttles of each should be set so as to give the required slow-running and synchronisation.

#### Slow-running and Synchronisation

Screw each throttle lever adjusting screw so that

its end is only just making contact with the web on the carburetter body, then give each screw one full turn exactly.

Start the engine, which will now idle on the fast side.

Unscrew each throttle lever adjusting screw an equal amount, a fraction of a turn at a time, until the desired slow-running speed is achieved.

Correct synchronisation can be checked by listening at each carburetter air intake in turn through a length of rubber tube and noticing if the noise produced by the incoming air is the same at both. Any variation in the intensity of the sound indicates that one throttle is set more widely open than the other—the louder sound indicating the throttle with the greater opening.

When the same intensity of sound is given by both carburetters the intercoupling shaft clip should be tightened up firmly to ensure that the throttles work in unison.

Since the delivery characteristics, when both carburetters are operating together, vary somewhat from those existing when each is working separately, it will be found necessary to check them again for correctness of mixture strength by lifting the pistons in turn as described in "Adjusting the jets", making such adjustments of the jet adjusting screws as are required to balance the mixture strength and to ensure that it is not too rich.

#### Fitting New Needles

If the road performance is not satisfactory after the above adjustments have been made, larger or smaller needles may be necessary.

To change the needles, remove the screws and lift off the suction chambers, having marked them to ensure

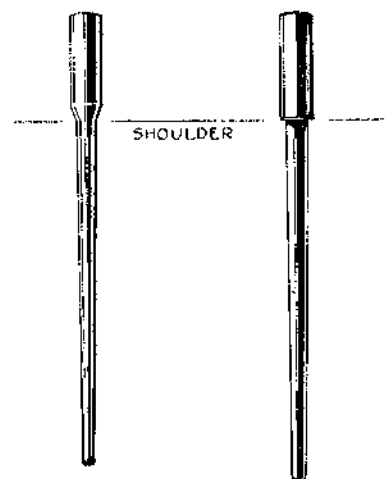

Fig. D.9. The shoulder of the needle should be flush with the under face of the piston. Two types of shoulder are in use and the correct datum point for each is shown.

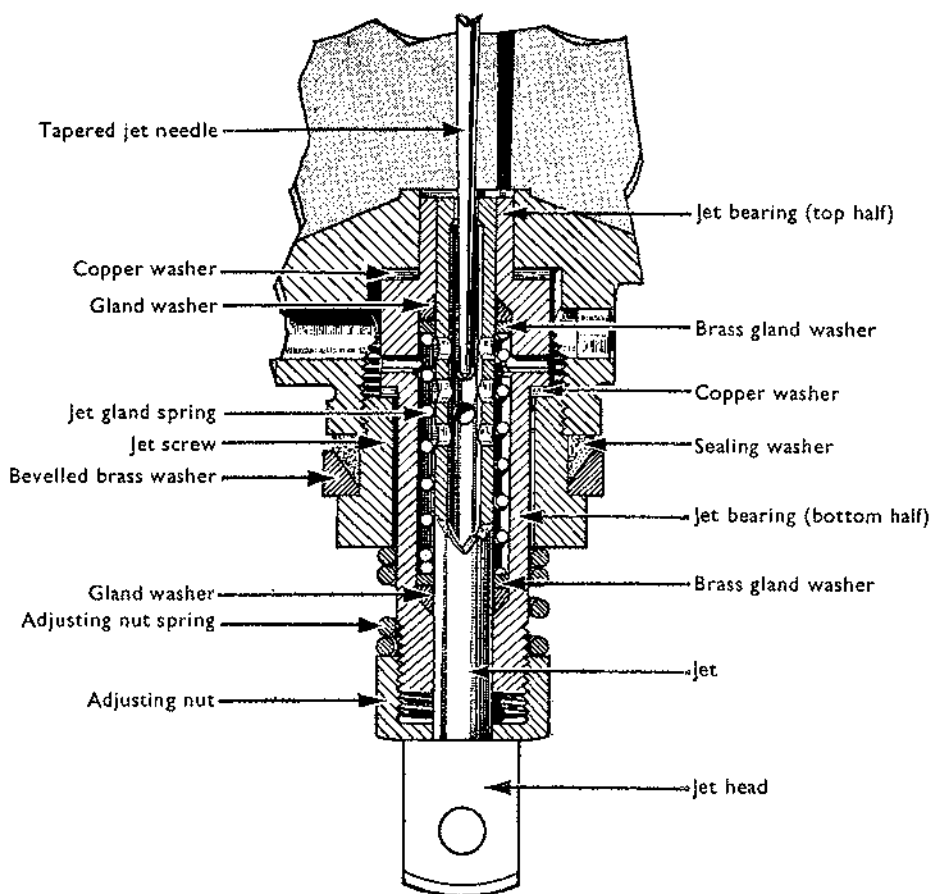

Fig. D.10. The jet assembly.

their refitting to their respective carburetters. Remove the pistons and return springs.

Unscrew the screw at the side of each piston tube and withdraw the needles.

Fit the new needles: a needle should be fitted with its shoulder flush with the face of the piston as shown in Fig. D.9.

### The Float-chamber

The position of the forked lever in the float-chamber must be such that the level of the float (and therefore the height of the fuel at the jet) is correct.

This is checked by inserting a  $\frac{1}{16}$  in. (11.11 mm.) round bar between the forked lever and the machined lip of the float-chamber lid. The prongs of the lever should just rest on the bar (see Fig. D.8) when the needle is on its seating. If this is not so, the lever should be reset at the point where the prongs meet the shank. Care must be taken not to bend the shank, which must be perfectly flat and at right angles to the needle when it is on its seating.

### Centering a Jet

First remove the clevis pin at the base of the jet which attaches the jet head to the jet operating lever; withdraw the jet completely, and remove the adjusting nut and the adjusting nut spring. Replace the adjusting nut without its spring and screw it up to the highest position. Slide the jet into position until the jet head is against the base of the adjusting nut. When this has been done, feel if the piston is perfectly free by lifting it up with the finger with the dashpot piston removed. If it is not, slacken the jet holding screw and manipulate the lower part of the assembly, including the projecting part of the bottom half jet bearing, adjusting nut and jet head. Make sure that this assembly is now slightly loose. The piston should then rise and fall quite freely as the needle is now able to move the jet into the required central position. The jet holding screw should now be tightened and a check made to determine that the piston is still quite free. If it is not found to be so, the jet holding screw should be slackened again and the operation repeated. When complete freedom of the

# D

## FUEL SYSTEM

piston is achieved the jet adjusting nut should be removed, together with the jet, and the spring replaced. The adjusting nut should now be screwed back to its original position.

Experience shows that a large percentage of carburettors returned for correction have had jets removed and incorrectly centred on replacement.

### Section D.9

#### SOURCES OF CARBURETTER TROUBLE

##### Piston Sticking

The piston assembly comprises the suction disc and the piston forming the choke, into which is inserted the hardened and ground piston rod which engages in a bearing in the centre of the suction chamber and in which is, in turn, inserted the jet needle. The piston rod running in the bearing is the only part which is in actual contact with any other part, the suction disc, piston, and needle all having suitable clearances to prevent sticking. If sticking does occur the whole assembly should be cleaned carefully and the piston rod lubricated with a spot of thin oil. No oil must be applied to any other part except the piston rod. A sticking piston can be ascertained by removing the dashpot piston damper, inserting a finger in the air intake and lifting the piston, which should come up quite freely and fall back smartly onto its seating when released.

##### Water or dirt in the Carburetter

When this is suspected, lift the piston: the jet can then be seen. Flood the carburetter and watch the jet; if the fuel does not flow through freely there is a blockage. To remedy this, start the engine, open the throttle, and block up the air inlet momentarily without shutting the throttle, keeping the throttle open until the engine starts to race. This trouble seldom arises with the S.U. carburetter owing to the size of the jet and fuel ways. When it does happen the above method will nearly

always clear it. Should it not do so, the only alternative is to remove the jet.

##### Float-chamber Flooding

This can be seen by the fuel flowing over the float-chamber and dripping from the air inlet, and is generally caused by grit between the float-chamber needle and its guide. This can usually be cured by depressing the float depressing plunger to allow the incoming flow of fuel to wash the grit through the guide and into the float-chamber.

##### Float Needle Sticking

If the engine stops, apparently through lack of fuel, when there is plenty in the tank and the pump is working properly, the probable cause is a sticking float needle. An easy test for this is to disconnect the pipe from the electric pump to the carburetter, switch on the ignition to check if fuel is delivered; if it is, starvation has almost certainly been caused by the float needle sticking to its seating, and the float-chamber lid should therefore be removed, the needle and seating cleaned, and refitted. At the same time it will be advisable to clean out the entire fuel feed system, as this trouble is caused by foreign matter in the fuel, and unless this is removed it is likely to recur. It is of no use whatever renewing any of the component parts of the carburetter, and the only cure is to make sure that the fuel tank and pipe lines are entirely free from any kind of foreign matter or sticky substance capable of causing this trouble.

### Section D.10

#### THE AIR CLEANERS

Remove the units and wash the gauze in petrol (gasoline) every 6,000 miles (10,000 km.) or every 3,000 miles (5,000 km.) in exceptionally dusty conditions.

When the gauze is clean and dry, re-oil it with engine oil and allow it to drain before refitting to the engine (see "Regular Attention").

### Section D.11

#### FAULT DIAGNOSIS

Symptom	No.	Possible Fault
(a) Leakage or insufficient fuel delivery	1	Air vent restricted.
	2	Pipes restricted or partially clogged.
	3	Air leakage at pipe connections
	4	Lift pump or carburetter filter gauze clogged.
	5	Lift pump gasket damaged
	6	Lift pump diaphragm damaged
	7	Lift pump valves sticking or seating improperly
	8	Fuel vaporising in pipe

# FUEL SYSTEM

**D**

Symptom	No.	Possible Fault
(b) Excessive fuel consumption	1	Carburettors out of adjustment
	2	Fuel leakage
	3	Controls sticking
	4	Air cleaners dirty
	5	Excessive engine temperature
	6	Brakes dragging
	7	Under-inflated tyres
	8	Excessive idling
	9	Vehicle overloaded
(c) Fast idling	1	Rich fuel mixture
	2	Carburettor controls sticking
	3	Slow-running screw incorrectly adjusted
(d) Lift pump inoperative	1	Feed cable loose or broken
	2	Poor earth return
	3	Excessive tension of lift pump diaphragm
	4	Blackened or pitted contact points
(e) Lift pump noise	1	Pump mountings loose
	2	Air leak on suction side
	3	Obstruction in pipe
	4	Filter obstructed
(f) Air leak on suction side of pump	1	Suction pipes, pump inlet or pump filter unions loose
	2	Insufficient fuel in the tank
	3	Faulty pipe

### MODIFICATION REFERENCES

<i>Service Reference Number</i>	<i>Date</i>	<i>Subject</i>	<i>Details of Changes</i>



# SECTION E

## CLUTCH

Section No. E.1	Description
Section No. E.2	Adjustment in vehicle
Section No. E.3	Clutch assembly
Section No. E.4	Clutch pedal
Section No. E.5	Master cylinder
Section No. E.6	Slave cylinder
Section No. E.7	Bleeding the clutch system
Section No. E.8	Fault diagnosis

---





## Section E.1

## DESCRIPTION

The clutch is a Borg & Beck single dry-plate-type operated hydraulically. A steel cover bolted to the flywheel encloses the driven plate, the pressure plate, the pressure springs, and the release levers. The driven plate, to which the friction linings are riveted, incorporates springs assembled around the hub to absorb power shocks and torsional vibration. The pressure springs force the pressure plate against the friction linings, gripping the driven plate between the pressure plate and the engine flywheel. When the clutch pedal is depressed, the release bearing is moved forward against the release plate which bears against the three levers. Each release lever is pivoted on a floating pin, which remains stationary in the lever and rolls across a short, flat portion of the enlarged hole in the eyebolt. The outer ends of the eyebolts extend through holes in the clutch cover and are fitted with adjusting nuts, by means of which each lever is located and locked in position. The outer or shorter ends of the release levers engage the pressure plate lugs by means of struts which provide knife-edge contact between the outer ends of the levers and the pressure plate lugs, so eliminating friction at this point. Pressure applied by the release bearing causes the pressure plate to be pulled away from the driven plate, compressing the pressure springs which are assembled between the pressure plate and the clutch cover. As the friction linings wear, the pressure plate moves closer to the flywheel face and the outer or shorter ends of the release levers follow. This causes the inner or longer ends of the levers to travel farther towards the gearbox and decreases the clearance between the release lever plate and the release bearing. This is automatically compensated unless the master cylinder has been disturbed.

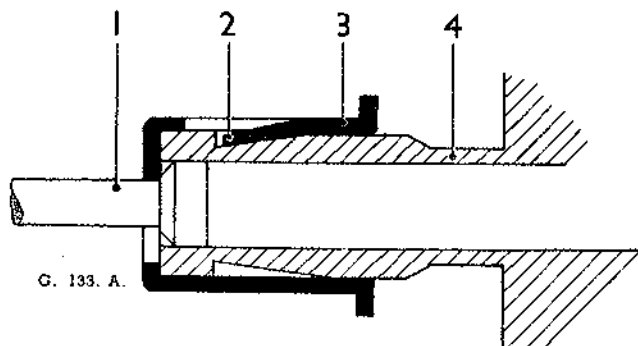

Fig. E.1. Diagrammatic section of master cylinder.

- |                  |             |
|------------------|-------------|
| 1. Valve stem.   | 3. Thimble. |
| 2. Thimble leaf. | 4. Plunger. |

When the clutch pedal is depressed, fluid pressure is transmitted through the master cylinder to the slave cylinder, which is mounted on the clutch housing, moving the slave cylinder piston, and push rod. As the push-rod is connected to the lower arm of the clutch withdrawal lever, thereby the clutch is released. The push rod is non-adjustable.

## Section E.2

## ADJUSTMENT IN VEHICLE

Owing to the hydraulic design of the clutch controls no adjustment is necessary to the clutch pedal.

## Section E.3

## CLUTCH ASSEMBLY

## To Remove

- (1) Remove the gearbox as described in Section F.
- (2) Slacken the clutch cover screws a turn at a time by diagonal selection until the spring pressure is relieved, when the screws can be taken out and the clutch removed.

## To Dismantle

When dismantling the clutch cover assembly the following parts should be suitably marked so that they can be reassembled in exactly the same relative positions to each other to preserve the balance and adjustment—the cover, the lugs on the pressure plate, and the release levers.

The clutch Tool No. 18G 99A provides an efficient and speedy means of dismantling, reassembling and adjusting the clutch with a high degree of accuracy. The tool is universal, and a chart detailing the sizes of spacing washers and distance-pieces for particular types of clutch is provided on the inside of the metal container lid. Proceed as follows :—

- (1) Detach the retaining springs from the release lever plate and remove the springs and plate.
- (2) Rest the tool base plate on a flat surface, ensure that it is clean, and place upon it spacing washers as directed by the chart. For this 9 in. (22.9 cm.) clutch select three washers and place them in position "D" on the base plate.
- (3) Position the clutch on the three spacing washers so that the hole in the clutch cover align with the tapped holes in the base plate, with the release levers as close to the spring washers as possible.
- (4) Insert the tool setscrews, tightening them a little at a time in a diagonal pattern, until the cover is firmly and evenly secured to the base plate. This is most important if the best results are to be achieved.

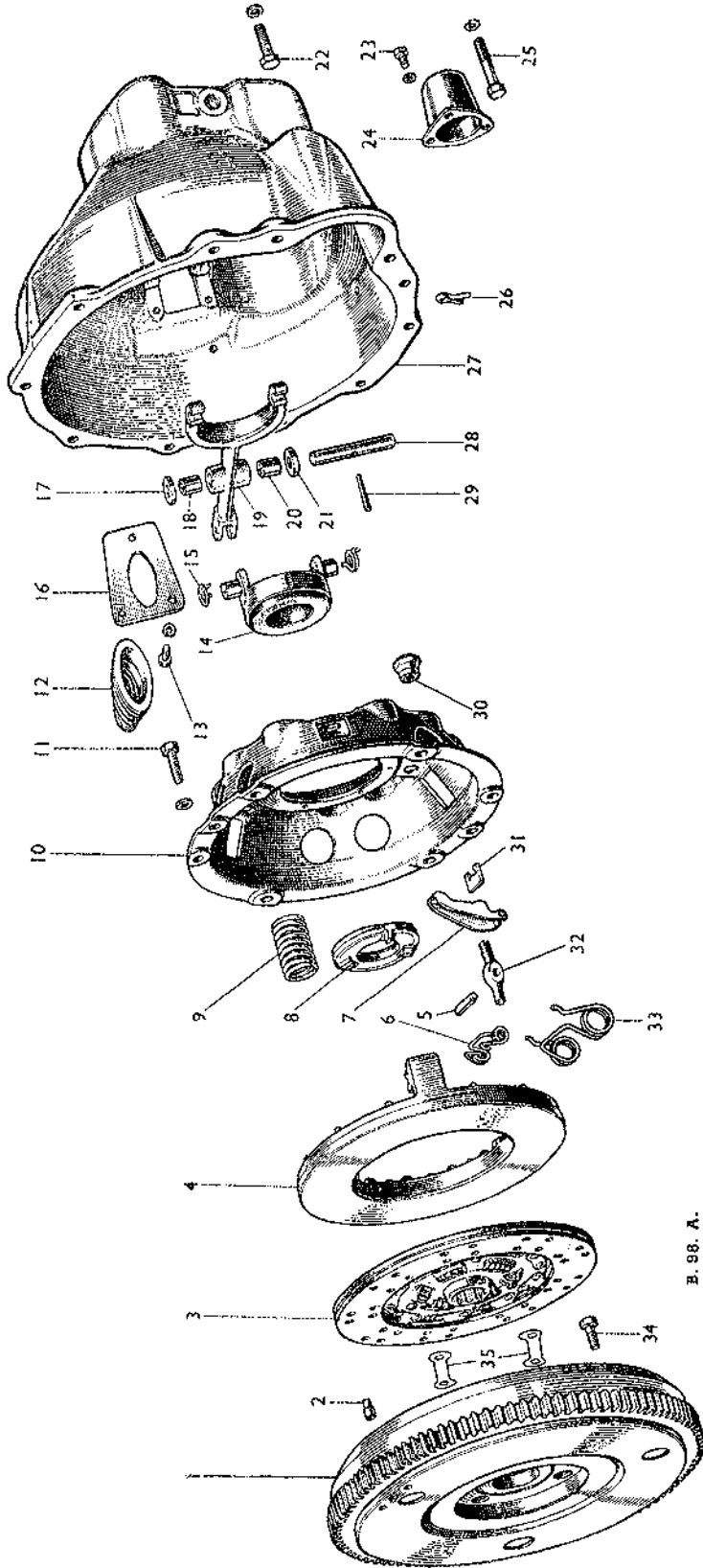

B. 98. A.

Fig. E.2. The clutch exploded.

- |                              |                                      |                                  |
|------------------------------|--------------------------------------|----------------------------------|
| 1. Flywheel.                 | 13. Retaining plate screw.           | 24. Cover.                       |
| 2. Locating peg.             | 14. Release bearing.                 | 25. Clutch to gearbox setpin.    |
| 3. Clutch plate with lining. | 15. Release bearing retainer spring. | 26. Split pin for drain hole.    |
| 4. Pressure plate.           | 16. Seal retaining plate.            | 27. Clutch housing.              |
| 5. Release lever retainer.   | 17. Fork and lever thrust washer.    | 28. Fork and lever shaft.        |
| 6. Release lever.            | 18. Fork and lever shaft bush.       | 29. Taper pin.                   |
| 7. Release lever plate.      | 19. Clutch fork and lever.           | 30. Eye bolt nut.                |
| 8. Pressure plate spring.    | 20. Fork and lever shaft bush.       | 31. Release lever strut.         |
| 9. Clutch cover.             | 21. Fork and lever thrust washer.    | 32. Eye bolt.                    |
| 10. Cover setpin.            | 22. Clutch to gearbox setpin.        | 33. Anti-rattle spring.          |
| 11. Cover setpin.            | 23. Starter cover screw.             | 34. Flywheel to crankshaft bolt. |
| 12. Fork and lever seal.     |                                      | 35. Lockwashers.                 |

## Section G.1

### LUBRICATION

The lubricating oil in the overdrive unit is common with that in the gearbox and the level should be checked with the gearbox dipstick.

It is essential that an approved lubricant be used when refilling. Trouble may be experienced if some types of extreme pressure lubricants are used because the planet gears act as a centrifuge to separate the additives from the oil.

Recommended lubricants are given in section Q. It should be emphasised that any hydraulically controlled transmission must have clean oil at all times and great care must be taken to avoid the entry of dirt whenever any part of the casing is opened.

Every 1,000 miles (1600 kilometres) check the oil level of the gearbox and overdrive and top up if necessary through the dipstick hole.

Every 6,000 miles (9600 kilometres) drain and refill the gearbox and overdrive unit. In addition to the normal drain plug fitted to the gearbox the overdrive unit incorporates a plug at its base which gives access to a filter. This plug should also be withdrawn to ensure that all used oil is drained away from the system.

Every 6,000 miles (9600 kilometres) after draining the oil, remove the overdrive oil pump filter and clean the filter gauze by washing in petrol. The filter is accessible through the drain plug hole and is secured by a central set bolt.

Refilling of the complete system (gearbox and overdrive) is accomplished through the gearbox filler plug. The capacity of the combined gearbox and overdrive unit is 5½ pints (6.3 U.S. pints; 2.98 litres).

After draining, ¼ pint of oil will remain in the overdrive hydraulic system, so that only 5 pints will be needed for refilling. If the overdrive has been dismantled the total of 5½ pints will be required.

After refilling the gearbox and overdrive with oil, recheck the level after the car has been run, as a certain

amount of oil will be retained in the hydraulic system of the overdrive unit.

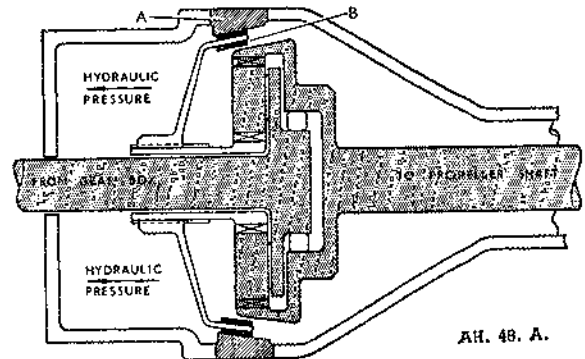

*Fig. G.2. Overdrive engaged.*

## Section G.2

### WORKING DESCRIPTION

The overdrive unit comprises a hydraulically controlled epicyclic gear housed in a casing which is directly attached to an extension at the rear of the gearbox.

The synchromesh gearbox third motion shaft is extended and carries at its end the inner member of a uni-directional clutch (see Fig. G.1). The outer member of this clutch is carried in the combined annulus and output shaft.

Also mounted on the third motion shaft are the planet carrier G and a freely rotatable sun wheel. Splined to a forward extension E of the sun wheel and sliding thereon is a cone clutch member D, the inner lining of which engages the outside of the annulus F while the outer lining engages a cast-iron brake ring sandwiched between the front and rear parts of the unit housing.

A number of compression springs is used to hold the cone clutch in contact with the annulus, locking the sun wheel to the latter so that the entire gear train rotates as a solid unit, giving direct drive. In this condition the drive is taken through the uni-directional clutch, the cone clutch taking over-run and reverse torque, as without it there would be a free-wheel condition.

The spring pressure can be overcome through the medium of two pistons, working in cylinders formed in the unit housing, supplied with oil under pressure from a hydraulic accumulator. This hydraulic pressure causes the cone clutch to engage the stationary brake ring (A Fig. G.2) and bring the sun wheel to rest, allowing the annulus to over-run the uni-directional clutch and give an increased speed to the output shaft, i.e. "overdrive".

When changing from overdrive to direct gear, if the accelerator pedal is released (as in a change down for engine braking) the cone clutch, being oil immersed, takes up smoothly. If the accelerator pedal is not

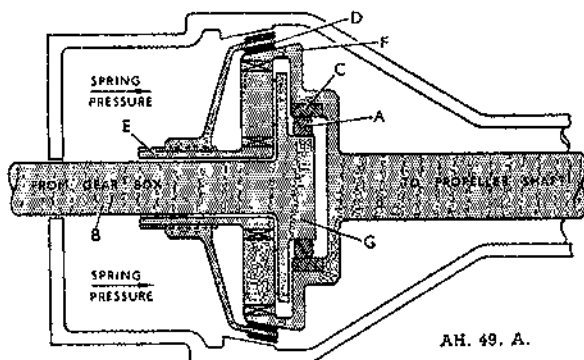

*Fig. G.1. Overdrive disengaged.*

OVERDRIVE

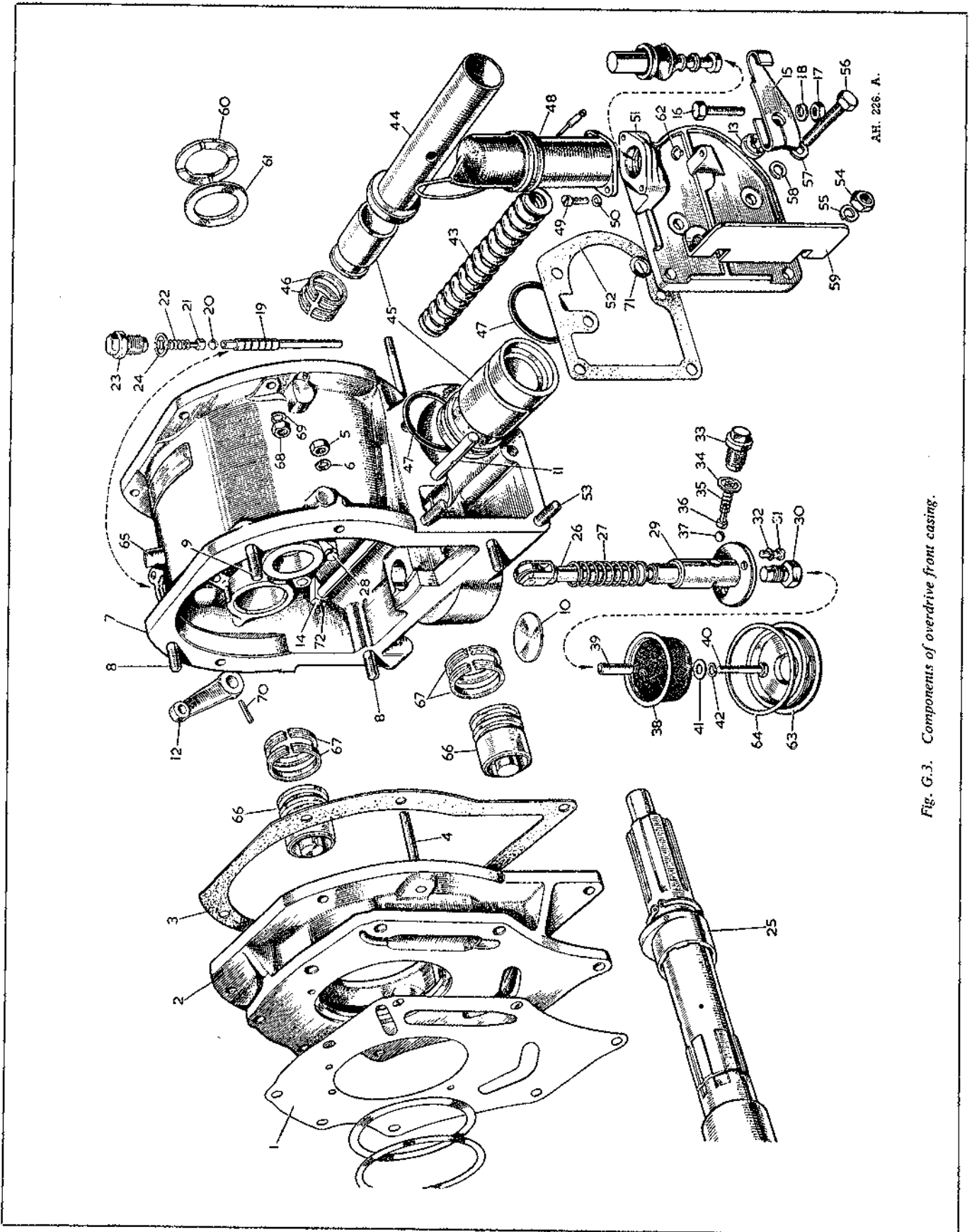

AH. 226. A.

Fig. G.3. Components of overdrive front casing.

## OVERDRIVE

Fig. G.3. Components of overdrive front casing.

1. Joint washer.	19. Valve push rod.	37. Ball valve.	55. Spring washer.
2. Adaptor plate.	20. Ball valve.	38. Pump filter.	56. Setpin.
3. Joint washer.	21. Ball valve plunger.	39. Distance piece.	57. Plain washer.
4. Locating stud.	22. Valve spring.	40. Filter bolt.	58. Spring washer.
5. Nut.	23. Valve plug.	41. Plain washer.	59. Solenoid shield.
6. Spring washer.	24. Copper washer.	42. Spring washer.	60. Thrust washer.
7. Main casing.	25. Third motion shaft.	43. Accumulator spring.	61. Spacing washer.
8. Stud.	26. Pump plunger.	44. Distance tube.	62. Rubber stop.
9. Stud.	27. Plunger spring.	45. Piston assembly.	63. Drain plug.
10. Welch plug.	28. Guide peg.	46. Piston rings.	64. Drain plug washer.
11. Valve operating shaft.	29. Pump body.	47. Rubber rings.	65. Breather.
12. Setting lever.	30. Pump body plug.	48. Solenoid unit.	66. Piston.
13. Collar.	31. Body screw.	49. Unit screw.	67. Piston rings.
14. Shaft cam.	32. Spring washer.	50. Spring washer.	68. Nut.
15. Solenoid lever.	33. Valve plug.	51. Solenoid lever housing.	69. Spring washer.
16. Adjusting screw.	34. Plug washer.	52. Joint washer.	70. Cotter pin.
17. Nut.	35. Valve spring.	53. Stud.	71. Oil seal.
18. Washer.	36. Ball valve plunger.	54. Nut.	72. Peg.

released, when contact between the cone clutch and brake ring is broken, the unit still operates momentarily in its overdrive ratio as engine speed and road speed remain unchanged. But the load on the engine is released and it begins to accelerate, speeding up the sun wheel from rest until, just at the instant when its speed synchronises with the speed of the annulus, the whole unit revolves solidly and the uni-directional clutch takes up the drive once more. The movement of the cone clutch is deliberately slowed down so that the uni-directional clutch is driving before the cone clutch contacts, ensuring a perfectly self-synchronised change.

## Section G.3

### CONSTRUCTION

The third motion shaft of the synchromesh gearbox is extended to carry first a cam operating the oil pump and then a steady bearing with two opposed plain bushes carried in the front housing. Next is the sun wheel of the epicyclic gear carried on a Clevite bush, and beyond this the shaft is splined to take the planet carrier and uni-directional clutch. The end of the shaft is reduced and carried in a plain bush in the output shaft. The latter is supported in the rear housing by two ball bearings. The clutch member slides on the splines of the sun wheel extension to contact either the annulus or a cast iron brake ring forming part of the unit housing.

To the hub of the cone clutch member is secured a ball bearing housed in a flanged ring. This ring carries on its forward face a number of pegs acting as guides to compression springs by which the ring, and with it the clutch member, is held against the annulus. The springs prevent free-wheeling on over-run and are of sufficient strength to handle reverse torque. Also secured to the ring are four studs picking up two bridge pieces against which bear two pistons operating in cylinders formed in the unit housing. The cylinders are connected through a

valve to an accumulator in which pressure is maintained by the oil pump. The operating pistons are fitted with special three-piece cast-iron rings, as also is the accumulator piston.

When the valve is open, oil under pressure is admitted to the cylinders and pushes the pistons forward to engage the overdrive clutch. Closing the valve cuts off the supply of oil to the cylinders and allows it to escape. Under the influence of the springs the clutch member moves back to engage direct drive position. The escape of oil from the cylinders is deliberately restricted so that the clutch takes about half a second to move over.

The sun wheel and pinions are cyanide case-hardened and the annulus heat-treated. Gear teeth are helical. The pinions have Clevite bushes and run on case-hardened pins.

The outer ring of the uni-directional clutch is pressed and riveted into the annulus member. The clutch itself is of the caged roller type, loaded by a lock-type spring made of round wire.

The hydraulic system is supplied with oil by a plunger type pump operated by a cam on the gearbox third motion shaft. The pump body is pressed into the front housing and delivers oil through a non-return valve to the accumulator cylinder, in which a piston moves back against a compression spring until the required pressure is reached when relief holes are uncovered. From the relief holes the oil is led through drilled passages to an annular groove between the two steady bushes on the gearbox third motion shaft.

Radial holes in the shaft collect the oil and deliver it along an axial drilling to other radial holes in the shaft from which it is fed to the sun wheel bush, thrust washers, planet carrier and planet pins.

From the accumulator, oil under pressure is supplied to the operating valve chamber. This forms an enlargement at the top of a vertical bore and contains a ball

# G

## OVERDRIVE

valve, the ball seating downwards thus preventing oil from circulating to the operating cylinders. The valve is a hollow spindle sliding in the bore, its top end reduced and carrying a seating for the ball, which is then lifted, admitting oil to the operating cylinders and moving the pistons forward to engage the overdrive clutch.

When the valve is lowered the ball is allowed to come on to its seating in the housing, cutting off pressure to the cylinders.

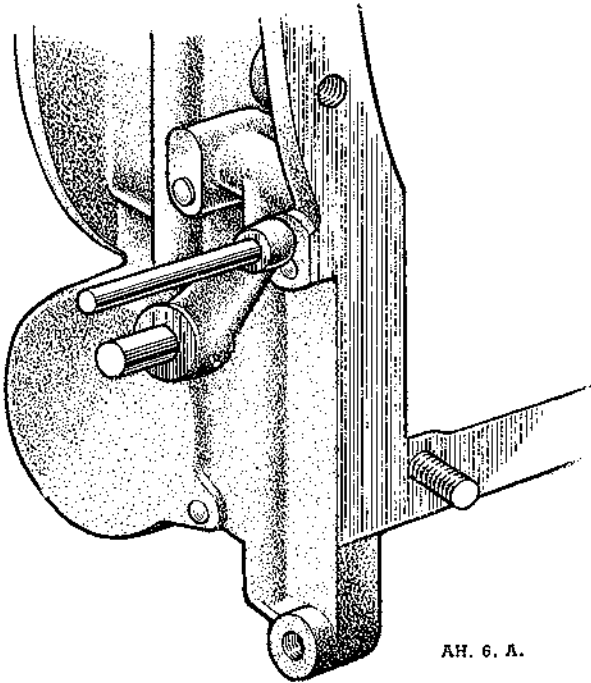

Fig. G.4. Valve setting lever.

Further movement of the valve brings it out of contact with the ball, allowing the oil from the cylinders to escape down the inside of the valve to discharge into the sump. The cone member then moves back under the influence of the clutch springs.

### Section G.4

#### SERVICING IN POSITION

When the overdrive does not operate properly it is advisable first to check the level of oil and, if below the requisite level, top up with fresh oil and test the unit again before making any further investigations.

**Before commencing any dismantling operations it is important that the hydraulic pressure is released from the system. Do this by operating the overdrive 10 to 12 times.**

As the unit is fitted with a speed responsive control it will be found more convenient to carry out this operation by moving the valve setting lever manually.

G.4

### Section G.5

#### GUIDE TO SERVICE DIAGNOSIS

##### Overdrive Does Not Engage

- (1) Insufficient oil in box.
- (2) Electric control not operating.
- (3) Leaking operating valve due to foreign matter on ball seat or broken valve spring.
- (4) Pump not working due to choked filter.
- (5) Pump not working due to broken pump spring.
- (6) Leaking pump non-return valve due to foreign matter on ball seat or broken valve spring.
- (7) Insufficient hydraulic pressure due to leaks or broken accumulator spring.
- (8) Damaged gears, bearings or moving parts within the unit requiring removal and inspection of the assembly.

##### Overdrive Does Not Release

- (1) Electric control not operating.
- (2) Blocked restrictor jet in valve.
- (3) Sticking clutch.
- (4) Damaged parts within the unit necessitating removal and inspection of the assembly.

##### Clutch Slip In Overdrive

- (1) Insufficient oil in gearbox.
- (2) Worn clutch lining.
- (3) Insufficient hydraulic pressure due to leaks.

##### Clutch Slip in Reverse or Free-Wheel Condition on Over-run

- (1) Worn clutch lining.
- (2) Blocked restrictor jet in valve.
- (3) Insufficient pressure on clutch due to broken clutch springs.

### Section G.6

#### OPERATING VALVE

Having gained access to the unit through the floor, unscrew the valve plug and remove the spring and plunger. The ball valve will then be seen inside the valve chamber. The ball should be lifted  $\frac{1}{2}$  in. (12.7 mm.) off its seat when the overdrive control is operated.

As the unit is fitted with a speed responsive control the appropriate parts of the electrical circuit must be shorted out in order to operate the control.

If the ball does not lift by this amount the fault lies in the control mechanism. Located on the right-hand side of the unit and pivoting on the valve operating cross shaft, which passes right through the housing, is a valve setting lever. In its outer end is a  $\frac{3}{16}$  in. (4.763 mm.) diameter hole which corresponds with a similar

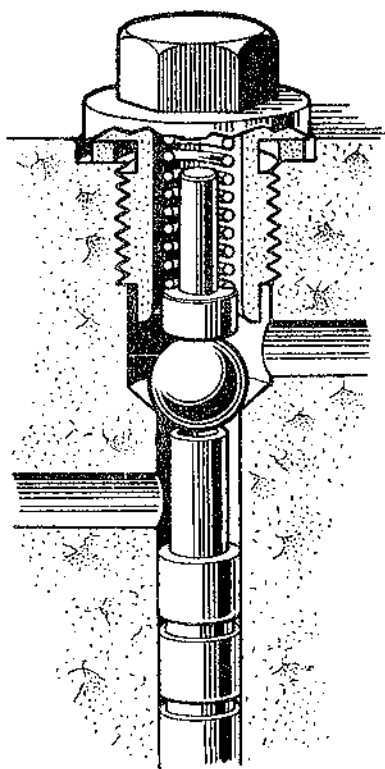

AH. 5. A.

Fig. G.5. The operating valve.

hole in the housing when the unit is in "overdrive" (i.e. when the ball is lifted  $\frac{1}{32}$  in. off the valve seat).

If the two holes do not line up, adjust the control mechanism until a  $\frac{3}{16}$  in. diameter rod can be inserted through the setting lever into the hole in the housing. Check lift of ball after completing the adjustment.

A small magnet will be found useful for removing the ball from the valve chamber. The valve can be withdrawn by inserting the tang of a file into the top, but care must be taken not to damage the ball seating at the end of the valve. Near the bottom of the valve will be seen a small hole breaking through to the centre drilling. This is the jet for restricting the exhaust of oil from the operating cylinders. Ensure that this jet is not choked.

## Section G.7

### HYDRAULIC SYSTEM

If the unit fails to operate and the ball valve is found to be seating and lifting correctly check that the pump is functioning.

Jack up the rear wheels of the car, then with the engine ticking over and the valve plug removed, engage top gear. Watch for oil being pumped into the valve chamber. If none appears then the pump is not functioning.

The pump (Fig. G.6) described above, is of the plunger type and delivers oil via a non-return valve to the accumulator. Possible sources of trouble are (1) failure of the non-return valve due to foreign matter on the seat or to a broken valve spring and (2) breakage of the spring holding the pump plunger in contact with the cam.

The pump is self priming, but failure to deliver oil after the system has been drained and refilled indicates that the air bleed is choked causing air to be trapped inside the pump.

In the unlikely event of this happening it will be necessary to remove the pump and clean the flat on the pump body and the bore of the casting into which it fits.

## Section G.8

### PUMP VALVE

Access to the pump valve is gained through a cover on the left-hand side of the unit. Proceed as follows:—

#### Solenoid Operated Units

- (1) Remove drain plug and drain off oil.
- (2) Remove solenoid.
- (3) Slacken off clamping bolt in operating lever and remove lever, complete with solenoid plunger.
- (4) Remove distance collar from valve operating shaft.
- (5) The solenoid bracket is secured by two  $\frac{5}{16}$  in. (7.938 mm.) studs and two  $\frac{1}{8}$  in. diameter bolts,

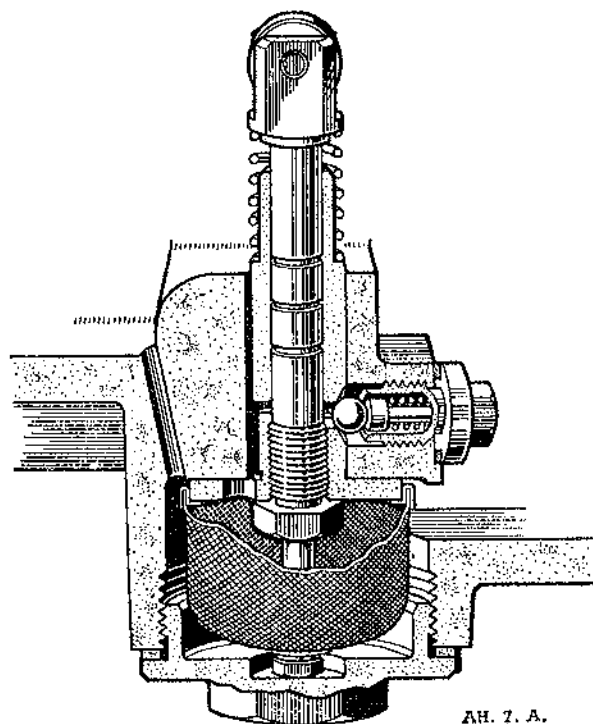

AH. 7. A.

Fig. G.6. The pump in cut-away form.

OVERDRIVE

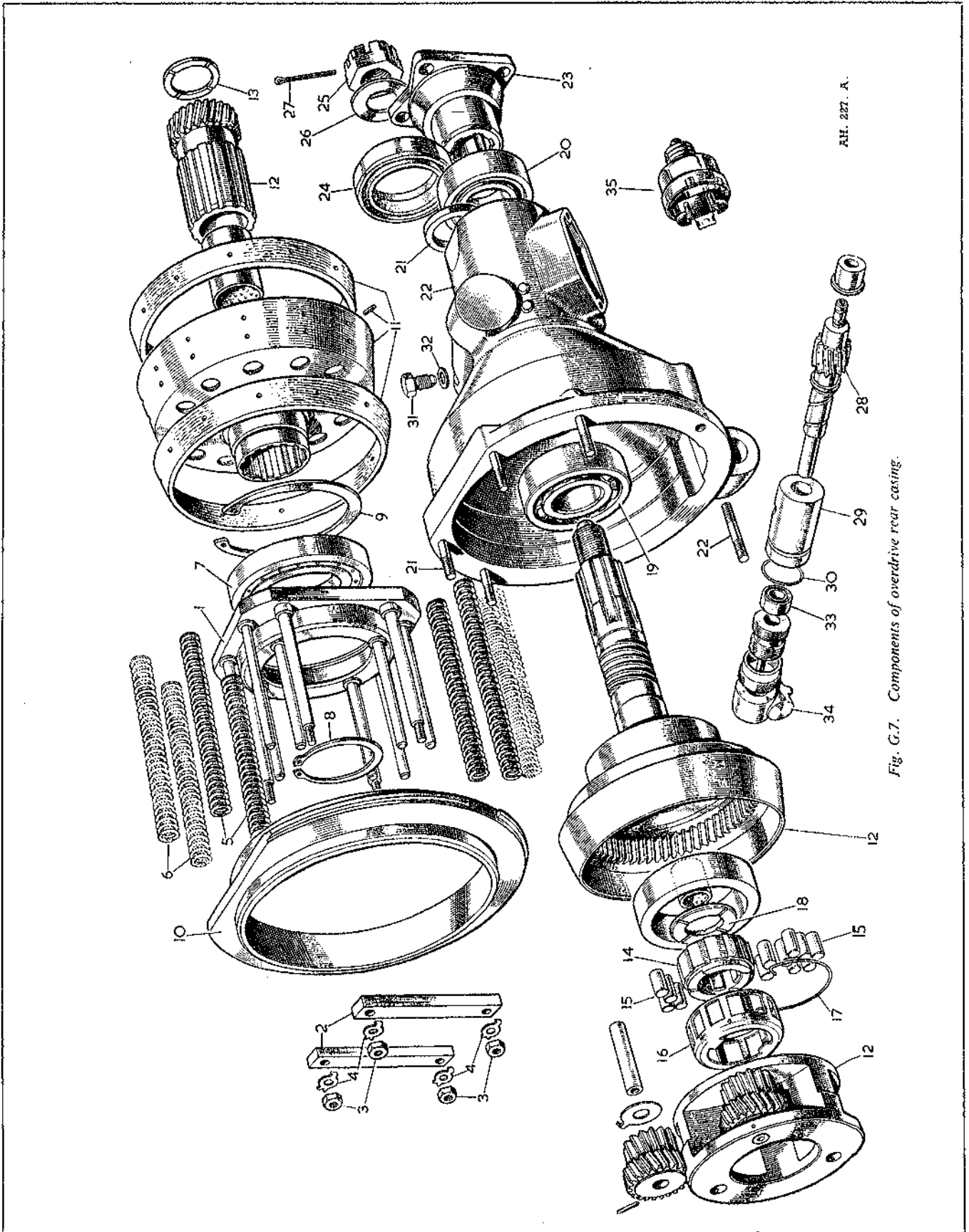

AH. 227. A.

Fig. G.7. Components of overdrive rear casing.



Fig. G.7. Components of overdrive rear casing.

- |                           |                             |                     |                          |
|---------------------------|-----------------------------|---------------------|--------------------------|
| 1. Clutch thrust ring.    | 10. Brake ring.             | 19. Inner bearing.  | 28. Speedometer spindle. |
| 2. Bridge pieces.         | 11. Clutch assembly.        | 20. Outer bearing.  | 29. Spindle sleeve.      |
| 3. Nuts.                  | 12. Sun wheel assembly.     | 22. Rear housing.   | 30. Washer.              |
| 4. Locking washers.       | 13. Thrust washer.          | 21. Spacing washer. | 31. Locking peg.         |
| 5. Clutch spring (long).  | 14. Uni-directional clutch. | 23. Driving flange. | 32. Washer.              |
| 6. Clutch spring (short). | 15. Rollers.                | 24. Oil seal.       | 33. Oil seal.            |
| 7. Front bearing.         | 16. Outer casing.           | 25. Flange nut.     | 34. Spindle adaptor.     |
| 8. Circlip (small).       | 17. Securing clip.          | 26. Washer.         | 35. Overdrive switch.    |
| 9. Circlip (large).       | 18. Thrust washer.          | 27. Split pin.      |                          |

the heads of which are painted red, **remove the nuts from the studs before touching the bolts. This is important.** The two bolts should now be slackened off together, releasing the tension on the accumulator spring.

- (6) Remove the solenoid bracket.
- (7) Unscrew the valve cap and take out the spring, plunger and ball.

Reassembly is the reverse of the above operations. Ensure that the soft copper washer between the valve cap and pump housing is nipped up tightly to prevent oil leakage.

It will now be necessary to reset the valve operating lever. Proceed as follows :—

Before clamping up the valve operating shaft rotate the shaft until a  $\frac{3}{8}$  in. (4.763 mm.) diameter pin can be inserted through the valve setting lever into the corresponding hole in the casing. Leave the pin in position, locking the unit in the overdrive position. Lift the solenoid plunger up to the full extent of its stroke (i.e. to its energised position) and clamp up the operating lever. The solenoid plunger bolt should now drop until it rests on the rubber stop immediately below (Fig. G.8). This stop gives the desired clearance between the plunger bolt and the boss situated on the solenoid bracket. Remove the pin through the setting lever and operate the lever manually to check that the control operates easily.

### To Dismantle the Pump

Proceed as follows :—

- (1) Remove the drain plug and drain off oil.
- (2) Remove pump valve as previously described.
- (3) Remove the filter after unscrewing the securing bolt.
- (4) Take out the two cheese head screws securing the pump body flange and extract the pump body. A special extractor tool is available for this purpose. This screws into the bottom of the pump body in the place of the screwed plug.

### Assembly of the Pump

Replace the plug in the bottom of the pump body, ensuring that it is screwed home tightly. Line up the pump body so that the inlet port and holes for securing screws register with the corresponding holes in the housing, and tap the pump body home.

The pump plunger is prevented from rotation when in position by a guide peg carried in the front casing. When assembling the pump the plunger should be inserted with the flat on its head facing the rear of the unit. It is possible to guide it past the guide peg by means of a screwdriver inserted through the side of the casting.

## Section G.9

### HYDRAULIC PRESSURE

A working oil pressure of 470 to 490 lbs. per sq. in. (33.04 to 34.45 kg./cm.<sup>2</sup>) is required.

The adaptor for use in connection with a pressure gauge is obtainable from the Austin Motor Company Ltd. under the Service Tool Number 18G 251.

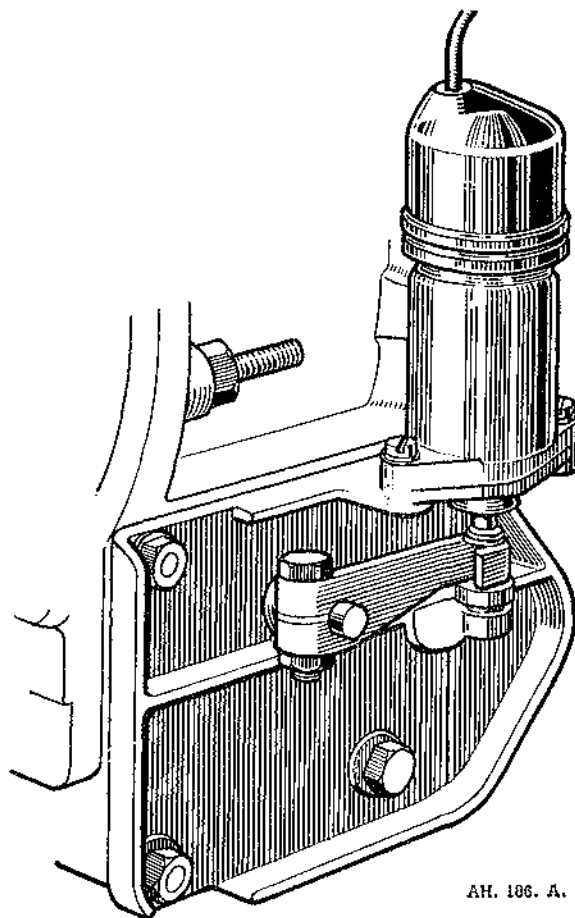

Fig. G.8. Showing the solenoid plunger bolt resting in the required position on the rubber stop.

## Section G.10

### DISMANTLING AND REASSEMBLING UNIT

#### Dismantling

Should trouble arise necessitating dismantling of the unit to a degree further than has already been described, it will be necessary to remove the unit from the car.

Whilst it is possible to lift out the overdrive alone from the car, it is advised that the gearbox and overdrive be removed as a single unit. It is far easier to refit the overdrive to the gearbox when the assembly is on a bench as the extended third motion shaft must be lined up with the splines of the uni-directional clutch.

The unit is split at the adaptor plate which is attached to the front casing by six  $\frac{5}{16}$  in. (7.938 mm.) studs, two of which are extra long. The four nuts on the shorter studs should be removed before those on the longer ones are touched. The latter should be unscrewed together releasing the compression of the clutch springs. The unit can then be drawn off the mainshaft, leaving the adaptor plate attached to the gearbox.

Remove the clutch springs from their pins. The two bridge pieces against which the operating pistons bear can now be removed. Each is secured by two  $\frac{1}{4}$  in. nuts locked by tab washers. Withdraw the two operating pistons.

As the adaptor plate is now separated from the unit the pump valve can be dismantled without removing the side cover (solenoid bracket) from the casing and there is no need to disturb the latter unless it is necessary to remove the accumulator piston and spring.

Remove the six  $\frac{5}{16}$  in. (7.938 mm.) nuts securing the two halves of the casing and separate them, removing the brake ring which is spigoted into the two pieces. Lift out the planet carrier assembly. Remove the clutch sliding member complete with the thrust ring and bearing, the sun wheel and thrust washers. Take out the inner member of the uni-directional clutch, the rollers, cage, etc.

If it is necessary to remove the planet gears from the carrier the three split pins securing the planet bearing shafts must be extracted before the latter can be knocked out.

To remove the annulus, first take off the coupling flange at the rear of the unit, remove the speedometer gear, centrifugal switch, etc., and drive out the annulus from the back. The front bearing will come away on the shaft leaving the rear bearing in the casing.

#### Inspection

Each part should be thoroughly inspected after the unit is dismantled and cleaned to ensure which parts should be replaced. It is important to appreciate the difference between parts which are worn sufficiently to

affect the operation of the unit and those which are merely "worn in".

- (1) Inspect the front casing for cracks, damage, etc. Examine the bores of the operating cylinders and accumulator for scores and wear. Check for leaks from plugged ends of the oil passages. Ensure that the Welch washer beneath the accumulator bore is tight and not leaking. Inspect the support bushes in the centre bore for wear and damage.
- (2) Examine the clutch sliding member assembly. Ensure that the clutch linings are not burned or worn. Inspect the pins for clutch springs and bridge pieces and see that they are tight in the thrust ring and not distorted. Ensure that the ball bearing is in good condition and rotates freely. See that the sliding member slides easily on the splines of the sun wheel.

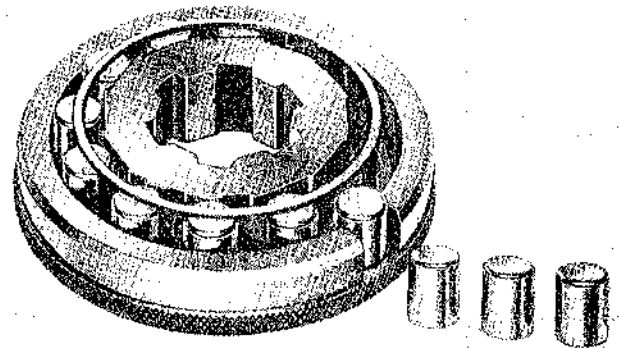

AM. 165. A.

Fig. G.9. Using tool 18G 173 for assembling the roller clutch

- (3) Check the clutch springs for distortion or collapse.
- (4) Inspect the teeth of the gear train for damage. If the sun wheel or planet bushes are worn the gears will have to be replaced since it is not possible to fit new bushes in service because they have to be bored true to the pitch line of the teeth.
- (5) Examine steel and bronze thrust washers.
- (6) See that the rollers of the uni-directional clutch are not chipped and that the inner and outer members of the clutch are free from damage. Make sure that the member is tight in the annulus. Ensure that the spring is free from distortion.
- (7) Inspect the ball bearings on the output shaft and see that there is no roughness when they are rotated slowly.
- (8) Ensure that there are no nicks or burrs on the mainshaft splines and that the oil holes are open and clean.
- (9) Inspect the oil pump for wear on the pump plunger and roller pin. Ensure that the plunger

spring is not distorted. Free length 2 in. (5.08 cm.). Inspect the valve seat and ball and make sure that they are free from nicks and scratches.

- (10) Check the operating valve for distortion and damage and see that it slides easily in its bore in the front casing.

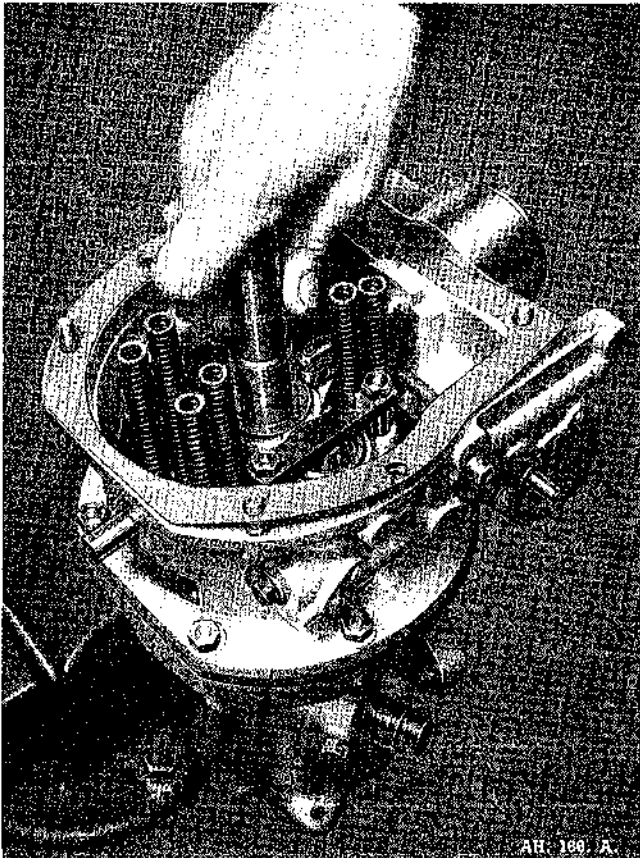

Fig. G.10. Centralising the gears with dummy mainshaft.

### Reassembling the Unit

The unit can be reassembled after all the parts have been thoroughly cleaned and checked to ensure that none are damaged or worn.

Assemble the annulus into the rear casing, not forgetting the spacing washer which fits between a shoulder on the shaft and the rear ball bearing. This washer is available in different thicknesses for selective assembly and should allow no end float of the annulus (output shaft) and no pre-loading of the bearings.

Selective washers are furnished in the following sizes :—

- 146 in.  $\pm$  ·0005 in. (3.7084 mm.  $\pm$  ·0127)
- 151 in.  $\pm$  ·0005 in. (4.335 mm.  $\pm$  ·0127)
- 156 in.  $\pm$  ·0005 in. (3.962 mm.  $\pm$  ·0127)
- 161 in.  $\pm$  ·0005 in. (4.089 mm.  $\pm$  ·0127)

Replace the thrust washer and uni-directional

clutch inner member with its rollers and cage. The fixture (Fig. G.9) is for retaining the rollers in position when assembling the clutch. Ensure that the spring is fitted correctly so that the cage urges the rollers up the ramps on the inner member.

Fit the pump cam on to the gearbox mainshaft, offer up the front housing to the cover plate and secure temporarily with two nuts. In order to determine the amount of end float of the sun wheel, which should be ·008 in. to ·014 in. (·203 mm. to ·3556 mm.) an extra thrust washer of known thickness should be assembled with the two normally used in front of the sun wheel.

Fit the planet carrier, with its planet gears over the sun wheel, and with the assembly in this position offer it up to the annulus. Turn the planet carrier until the locating peg on the inner member of the uni-directional clutch enters the corresponding hole in the planet carrier. This lines up the splines in the two members.

Assemble the brake ring to the front casing then offer up the front and rear assemblies, leaving out the clutch sliding member with its springs, etc. The gap between the flanges of the brake ring and rear casing should be measured. This gap will be less than the thickness of the extra thrust washer by the amount of end float of the sun wheel. If this is between the limits specified the unit may be stripped down again and re-assembled without the extra thrust washer. The clutch sliding member bridge pieces, etc., must now be replaced. The compression of the springs is taken up on the two long studs between the front casing and adaptor plate.

If the indicated end float is more, or less, than that required it must be adjusted by replacing the steel thrust washer at the front of the sun wheel by one of less or greater thickness, as required. Washers of varying thickness are stocked for this purpose.

Seven sizes are available, as follows :—

- 113 in. to ·114 in. (2.87 mm. to 2.985 mm.)
- 107 in. to ·108 in. (2.718 mm. to 2.743 mm.)
- 101 in. to ·102 in. (2.565 mm. to 2.59 mm.)
- 095 in. to ·096 in. (2.413 mm. to 2.438 mm.)
- 089 in. to ·090 in. (2.26 mm. to 2.286 mm.)
- 083 in. to ·084 in. (2.108 mm. to 2.134 mm.)
- 077 in. to ·078 in. (1.956 mm. to 1.981 mm.)

Care must be taken to ensure that the thrust washers at the front and rear of the sun wheel are replaced in their correct positions. At the front of the sun wheel the steel washer fits next to the head of the support bush in the housing and the bronze washer between the steel one and the sun wheel. At the rear, the steel washer is sandwiched between the two bronze washers.

Grip the mounting flange of the overdrive unit in a vice, so that the unit is upright, and insert a dummy shaft 18G 185 or a spare mainshaft if the dummy shaft is not available, so that the sun wheel and thrust washers,

planet carrier and roller clutch line up with each other; a long thin screwdriver should be used to line by eye the splines in the planet carrier and the roller clutch before inserting the dummy shaft. Gently turn the coupling flange to and fro while holding the dummy shaft, to assist in feeling the shaft into the splines of the planet carrier and roller clutch. Make sure that the dummy shaft has gone right in by holding the coupling flange in one hand and turning the shaft to and fro to feel the free-wheel action of the roller clutch.

Make quite sure that the clutch springs are in their correct positions—the 4¼ in. (10.8 cm.) long springs are the inner ones, and the 4½ in. (11.5 cm.) ones are the outer. This is most important because if any of the springs are in the wrong position they will become “coil bound” when the adaptor plate is in place and restrict the movement of the sliding clutch so that overdrive will not engage.

Place the oil pump operating cam in position on top of the centre bushing with the lowest part of the cam in contact with the oil pump plunger and also place the paper joint washer in position.

The gearbox, with top gear engaged, should now be lifted by hand on to the overdrive unit, carefully threading the mainshaft through the oil pump cam and into the centre bushing in the body of the overdrive unit. Gently turn the first motion shaft to and fro to assist in “feeling” the mainshaft into the splines of the planet carrier. When the mainshaft is sufficiently entered for the gearbox to come to rest against the clutch springs with the two long studs just protruding through the holes in the overdrive body, put the spring washers and nuts on to the end of the studs. Before commencing to tighten the nuts, use a long thin screwdriver to guide the ends of the clutch springs on to the short locating pegs which are cast into the face of the adaptor plate—this is very important because if the springs are not properly located they may become “coil bound” and prevent overdrive engaging. Now commence simultaneously to tighten the nuts on the two long studs, compressing the clutch springs and drawing the gearbox and overdrive together evenly. As the gearbox and overdrive come together watch carefully to see the splines on the mainshaft enter the oil pump operating cam and that the cam remains properly engaged with the oil pump plunger. If the two units do not pull together easily with only the resistance of the clutch springs being felt as the two nuts are tightened, stop tightening immediately. Gently rotate the gearbox first motion shaft in a clockwise direction whilst holding the overdrive coupling flange stationary until the mainshaft is felt to enter the roller clutch. The tightening of the nuts on the two long studs can then be completed, and the nuts fitted and tightened on to the four short studs.

**Note:** The gearbox mainshaft should enter the overdrive easily, provided that the lining-up procedure previously described is carried out and the unit is not disturbed. If any difficulty is experienced it is probable that one of the components has become misaligned, and the gearbox should be removed and the overdrive re-aligned with the dummy shaft.

## Section G.11

### OVERDRIVE RELAY SYSTEM

#### Description

Engagement of overdrive is controlled electrically through a manually operated toggle switch. The circuit shown in Fig. G.11 includes the following components :

- (i) Relay, model SB40. An electro-magnetic switch used with item (ii) to enable an interlocking safeguard to be incorporated against changing out of overdrive with throttle closed.
- (ii) Throttle Switch, model RTS1. A lever-operated semi-rotary normally closed switch used in conjunction with item (i) to override the toggle switch under closed throttle conditions.
- (iii) Gear Switch, model SS10. A small plunger-operated switch allowing overdrive to be engaged only in the two highest forward-gear positions.
- (iv) Solenoid Unit, model TGS1. An electro-magnetic actuator to engage overdrive mechanism by opening hydraulic control valve.

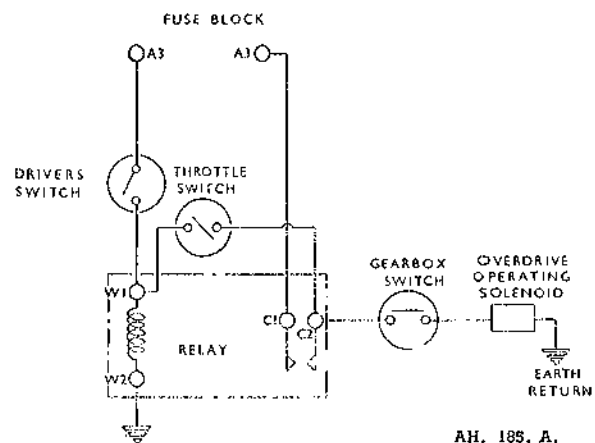

Fig. G.11. Wiring diagram for the overdrive electrical circuit

#### Operation

When the toggle switch contacts are closed, current flows by way of the ignition switch and fuse unit supply terminal A3 to energize the relay operating coil. Closure of the relay contacts connects terminal A3 to the gear switch and, providing one of the two higher ratio gears is engaged, will energize the solenoid unit and effect a change from direct drive to overdrive.

# OVERDRIVE

# G

Overdrive will be maintained until the solenoid unit is de-energized.

Change from overdrive to direct drive is effected either by selecting a low gear (when the gear switch contacts will open) or by turning the toggle switch to off with open throttle (when the relay contacts will open).

If effected with closed throttle, a change from overdrive to direct drive could result in a shock to the transmission. An interlocking circuit is therefore incorporated to override the toggle switch under closed throttle conditions. Under these conditions, the throttle switch contacts provide an alternative supply circuit to the relay operating coil.

## Maintenance

Regular attention should be paid to wiring and connections. Damaged cabling must be replaced and loose terminals tightened, including the relay and solenoid unit earthing connections.

## Section G.12

### FAULT TRACING

#### The Solenoid Unit

With engine stopped and neutral gear engaged and ignition switched on, disconnect the solenoid connection. Using a jumper lead, momentarily connect the solenoid to fuse unit supply terminal A3. The solenoid should be heard to operate. If no sound is heard, the solenoid is defective or incorrectly adjusted to the operating linkage. Remake the connection.

#### The Gear Switch

Engage top gear, depress the throttle pedal and momentarily connect relay terminal C2 to terminal A3. The solenoid should be heard to operate. If no sound is heard, the gear switch is defective. Re-engage neutral gear.

#### The Relay Coil

Momentarily connect relay terminal W1 to terminal A3. The relay should be heard to operate. If no sound is heard, the relay is defective.

#### The Toggle Switch

Operate the toggle switch. The relay should be heard to operate. If no sound is heard, the toggle switch is defective.

#### The Relay Contacts

With top gear engaged, toggle switch closed and throttle switch open, the solenoid should be heard to operate. If no sound is heard, the relay is defective.

#### The Throttle Switch

Engage top gear and close toggle switch. Open toggle switch and slowly depress accelerator. The solenoid should be energized from zero to one-quarter throttle. If the solenoid is heard to release under one-quarter throttle, the throttle switch is defective.

### MODIFICATION REFERENCES

<i>Service Reference Number</i>	<i>Date</i>	<i>Subject</i>	<i>Details of Changes</i>



# **SECTION H**

## **PROPELLER SHAFT**

Section No. H.1	Description
Section No. H.2	Lubrication
Section No. H.3	Propeller shaft assembly
Section No. H.4	Fault diagnosis

---





# PROPELLER SHAFT

# H

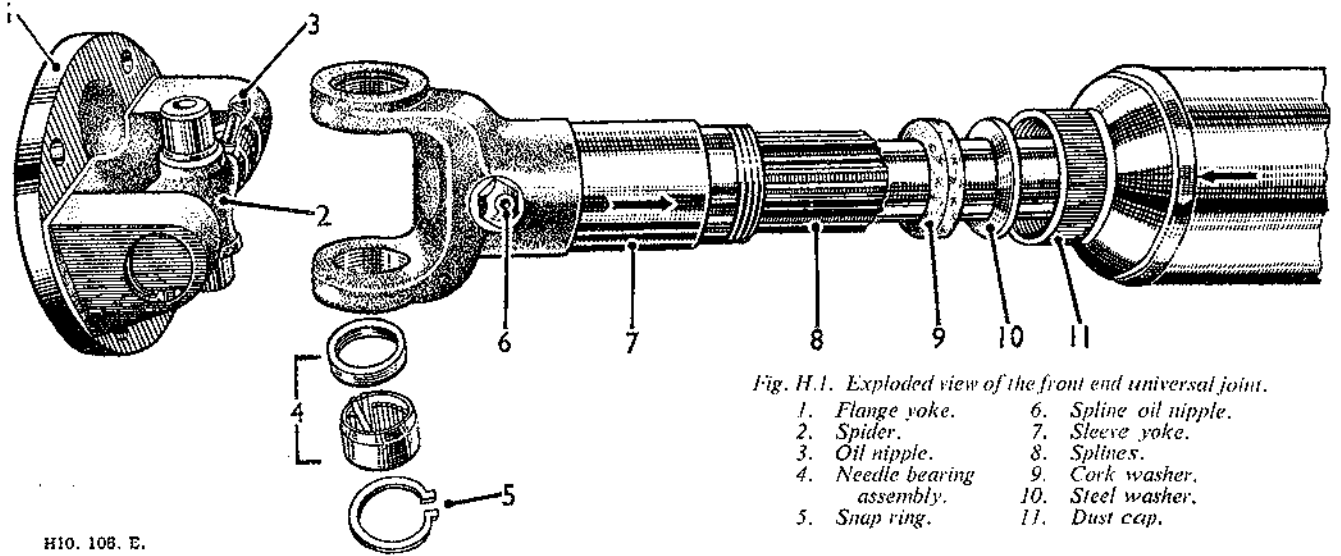

Fig. H.1. Exploded view of the front end universal joint.

- |                             |                       |
|-----------------------------|-----------------------|
| 1. Flange yoke.             | 6. Spline oil nipple. |
| 2. Spider.                  | 7. Sleeve yoke.       |
| 3. Oil nipple.              | 8. Splines.           |
| 4. Needle bearing assembly. | 9. Cork washer.       |
| 5. Snap ring.               | 10. Steel washer.     |
|                             | 11. Dust cap.         |

## Section H.1

### DESCRIPTION

The propeller shaft and universal joints (Fig. H.1) are of Hardy Spicer manufacture.

The fore and aft movement of the rear axle and other components is allowed for by a sliding spline between the propeller shaft and gearbox unit. Each universal joint consists of a centre spider, four needle roller bearings and two yokes. Reference to the Lubrication Chart, see Section Q, shows the location of the joints.

## Section H.2

### LUBRICATION

An oil nipple is fitted to each centre spider for the lubrication of the bearings. Grease must not be used,

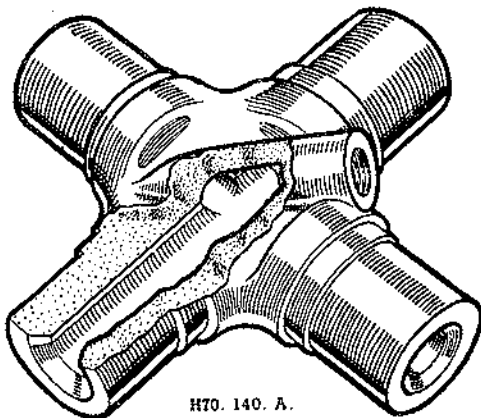

Fig. H.2. Showing oil channels in a joint spider.

oil being the correct lubricant. Reference to fig. H.2 shows that the central oil chamber is connected to the four oil reservoirs and to the needle roller bearing assemblies.

The needle roller bearings are filled with oil on assembly. An oil nipple is provided on the sleeve yoke of the sliding spline joint for lubrication of the splines.

If a large amount of oil exudes from the oil seals the joint should be dismantled and new oil seals fitted.

After dismantling, and before reassembly, the inside splines of the sleeve yoke should be smeared liberally with oil.

## Section H.3

### PROPELLER SHAFT ASSEMBLY

#### Tests for Wear

- (1) Wear on the thrust faces is located by testing the lift in the joint, either by hand, or by using a length of wood suitably supported.
- (2) Any circumferential movement of the shaft relative to the flange yokes, indicates wear in the needle roller bearings, or the sliding spline.

#### Removal of Complete Assembly

Before removal of the propeller shaft can be effected, the short length of tunnel immediately to the rear of the gearbox must be removed.

The removal procedure for the propeller shaft is as follows:—

- (1) Support the shaft near the sliding joint, then withdraw the bolts from the gearbox companion flange.
- (2) Unscrew, by hand, the dust cap at the rear of the sliding joint. Slide the splined sleeve yoke about

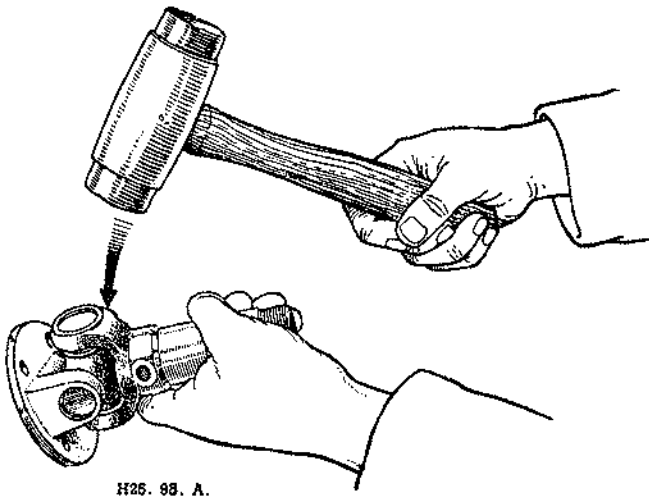

H25. 93. A.

Fig. H.3. Tapping the joint to extract bearing.

half an inch rearwards, thus disengaging the pilot flanges.

- (3) Remove the four nuts and bolts securing the rear flange yoke from the axle companion flange and lower the propeller shaft to the ground.
- (4) The propeller shaft and the two universals can now be taken to the bench for further dismantling.

### Dismantling

The following directions apply to both universal joints of the propeller shaft except for the fact that the front joint can be separated from the shaft, whereas the rear joint has one yoke permanently fixed to the tube.

- (1) Clean away the enamel from all the snap rings and bearing faces, to ensure easy extraction of the bearings.
- (2) Remove the snap rings by pressing together the ends of the rings and extract with a screwdriver. If the ring does not come out easily, tap the bearing face lightly to relieve the pressure against the ring.
- (3) Hold the splined end of the shaft in one hand and tap the radius of the yoke with a lead or copper hammer (see fig. H.3), when it will be found that the bearing will begin to emerge. If difficulty is experienced, use a small bar to tap the bearing from the inside, taking care not to damage the race itself. Turn the yoke over and extract the bearing with the fingers (see fig. H.4), being careful not to lose any of the needles.
- (4) Repeat this operation for the other bearing, and the splined yoke can be removed from the spider (see fig. H.5).
- (5) Using a support and directions as above remove the spider from the other yoke.

### Examination and Checking for Wear

After long usage the parts most likely to show signs of wear are the bearing races and the spider journals of the universal joints. Should looseness or stress marks be observed, the assembly should be renewed complete, as no oversize journals or bearings are provided.

It is essential that bearing races are a light drive fit in the yoke trunnions. Should any ovality be apparent in the trunnion bearing holes, new yokes must be fitted.

With reference to wear of the cross holes in a fixed yoke, which is part of the tubular shaft assembly, only in cases of emergency should this be replaced. It should normally be renewed with a complete tubular shaft assembly. The other parts likely to show signs of wear are the splined sleeve yoke, or splined stub shaft. A total of .004 in. circumferential movement, measured on the outside diameter of the spline, should not be exceeded. Should the splined stub shaft require renewing, this must be dealt with in the same way as the fixed yoke, *i.e.* a replacement tubular shaft assembly fitted.

### Reassembly

- (1) See that all drilled holes in the journals of the Universal joints are cleaned out and filled with oil.
- (2) Assemble the needle rollers in the bearing races and fill with oil. Should difficulty be experienced in assembly, smear the walls of the races with vaseline to retain the needle rollers in place.

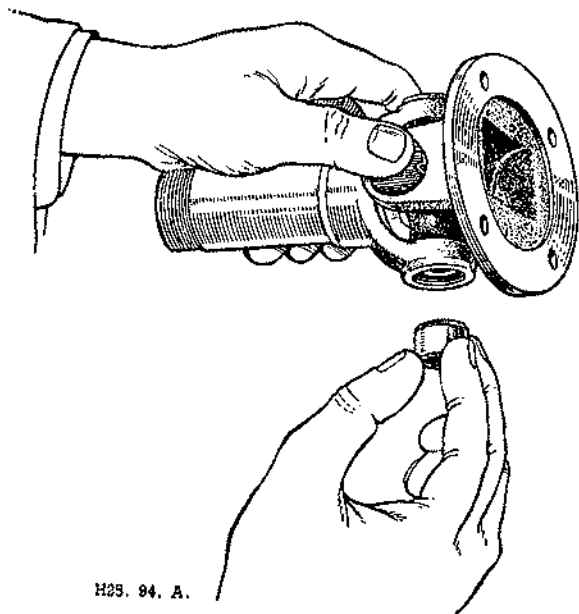

H25. 94. A.

Fig. H.4. Withdrawing a bearing cup

- (3) Insert the spider in the flange yoke.
- (4) Using a soft-nosed drift about  $\frac{1}{2}$  in. smaller in diameter than the hole in the yoke, tap the bearing in position. It is essential that bearing races are a light drive in the yoke trunnion.
- (5) Repeat this operation for the other three bearings. The spider journal shoulders should be coated with shellac prior to fitting the retainers to ensure a good seal.
- (6) If the joint appears to bind, tap lightly with a wooden mallet which will relieve any pressure of the bearings on the end of the journals. When replacing the sliding joint on the shaft, be sure that the trunnions in the sliding and fixed yoke are in line. This can be checked by observing that arrows marked on the splined sleeve yoke and the splined stub shaft are in line. It is advisable to renew cork washers and washer retainers on spider journals, using a tubular drift.

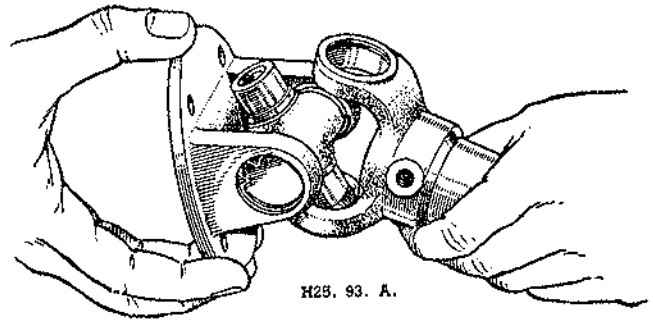

*Fig. H.5. Separating the joint.*

### Replacing the Shaft Assembly

- (1) Wipe the companion flange and flange yoke faces clean, to ensure that the pilot flange registers properly and the joint faces bed evenly all round.
- (2) Insert the bolts, and see that the nuts are tightened evenly all round and are securely locked.
- (3) The dust cap must be screwed up by hand as far as possible. The sliding joint is always placed towards the front of the car.

## Section H.4

## FAULT DIAGNOSIS

Symptom	No.	Possible Fault
(a) Vibration	1	Shaft bent or misaligned
	2	Worn universal joint bearings or spider bearing journal
	3	Sliding joint splines badly worn
	4	Loose flange bolts



# **SECTION J**

## **REAR AXLE AND SUSPENSION**

Section No. J.1	Lubrication
Section No. J.2	Axle unit
Section No. J.3	Axle shafts
Section No. J.4	Hubs
Section No. J.5	Bevel pinion and differential
Section No. J.6	Crown wheel and pinion
Section No. J.7	Rear springs
Section No. J.8	Shock absorbers
Section No. J.9	Anti-sway bar
Section No. J.10	Fault diagnosis

---



## Section J.1

### LUBRICATION

For the lubrication of the hypoid axle use lubricants only from approved sources, as tabulated in Section Q. Do not, under any circumstances mix various brands of hypoid lubricant. If there is any doubt as to the oil previously used, drain and flush the axle with a little new hypoid oil before finally filling up. Do not use paraffin as a flushing medium. On a new car the oil should be drained and the axle refilled at 500 miles (750 km.) and subsequently every 6,000 miles (10,000 km.), failure to do this will eventually lead to axle break-down.

The filler plug is situated on the rear side of the axle, and the drain plug in the bottom of the banjo casing.

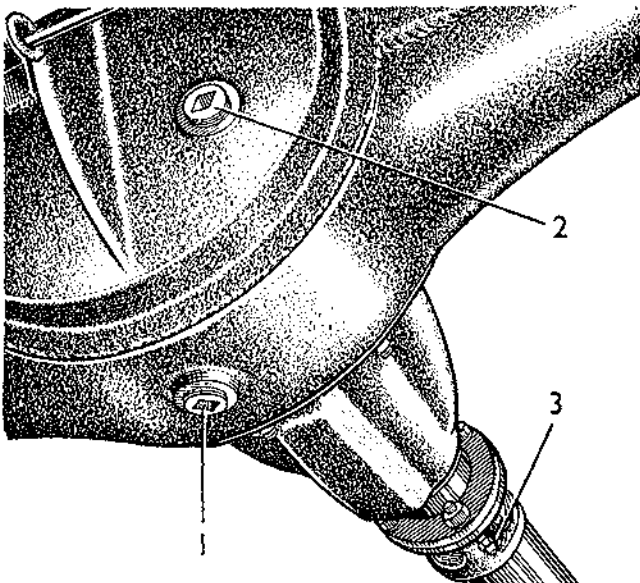

B. 183. A.

Fig. J.1. Rear axle.

1. Drain plug. 2. Filler plug. 3. Propeller shaft universal nipple.

## Section J.2

### AXLE UNIT

#### To Remove and Replace

- (1) Loosen the wheel nuts or hub caps, then jack-up the car and place supports under frame members just forward of the rear springs front anchorage. Take off both wheels after removing the wheel nuts or hub caps.
- (2) Working from under the car, unscrew the four self-locking nuts and remove the bolts (U.N.F.) securing the propeller shaft flange to axle pinion flange.
- (3) Disconnect the handbrake cable from the axle. This is accomplished by unscrewing it from its link to the brake balance lever, and unscrewing the nut holding its outer casing to the axle.

- (4) The hydraulic brake pipe at the rear axle is detached from the flexible pipe at the union just forward of the right hand shock absorber.
- (5) Unscrew the nuts securing the shock absorber links to the axle mounting brackets. Do not attempt to remove the links as this operation will prove much easier when freeing the axle.
- (6) Remove the self-locking nuts from the spring clips ("U" bolts) which secure the axle to the springs. Observe that a fibre pad is situated between the axle and spring.
- (7) Disconnect the anti-sway bar at its axle anchorage by unscrewing its securing nuts.
- (8) With the axle free the connecting links from the shock absorbers should be detached.
- (9) Remove the rubber block fixed between the axle and the left hand chassis frame. It is not necessary to detach the corresponding block on the right hand chassis frame.
- (10) The complete axle should be removed from the right-hand side of the car. Take care not to damage other components, particularly the petrol pump.
- (11) Installing the axle is the reverse of the above operations.

On re-assembling, it is advisable to jack-up the springs to meet the axle thus locating the spring centre bolt properly. Remember to fit the fibre pad.

When assembly is complete adjust the handbrake if required and bleed the hydraulic brake system all round.

## Section J.3

### AXLE SHAFTS

#### To Remove and Replace

- (1) Loosen the wheel nuts or hub cap of the wheel concerned before jacking-up the car.
- (2) Remove the wheels after further unscrewing the wheel nuts or hub caps.
- (3) Take out the two drum locating screws, using a screwdriver.

**Note.**—If wire wheels are fitted it will be necessary to remove the five self-locking nuts, which secure the rear hub extension, to give access to the two drum locating screws.

- (4) The drum can be tapped off the hub and brake linings, provided the handbrake is released and the brake shoes are not adjusted so closely as to bind on the drum.

Should the brake linings hold the drum when the handbrake is released, it will be found necessary to slacken the brake shoe adjuster a few notches.

# J

## REAR AXLE AND SUSPENSION

- (5) Remove the axle shaft retaining screw and draw out the axle shaft by gripping the flange outside the hub. It should slide easily but if it is tight on the studs it may need gently prising with a screwdriver inserted between the flange and the hub. Should the paper washer be damaged it must be renewed when re-assembling.
- (6) Replacement is a reversal of the above operations. Make sure that the bearing spacer is in position.

**Note.**—The bearing is not adjustable and is replaced in one straightforward operation.

When re-assembling it is essential that the outer face of the bearing spacer should protrude from .001 in. (.025 mm.) to .004 in. (.091 mm.) beyond the outer face of the hub and the paper washer, when the bearing is pressed into position. This ensures that the bearing is gripped between the abutment shoulder in the hub and the driving flange of the axle shaft.

### Section J.4

#### HUBS

##### To Remove and Replace

- (1) Remove the drum, axle shaft and bearing spacer.
- (2) Knock back the tab of the locking washer and unscrew the nut with Service Tool 18G 258.
- (3) Tilt the lock washer to disengage the key from the slot in the threaded portion of the axle casing; remove the washer.
- (4) The hub can then be withdrawn with a suitable extractor such as Service Tool No. 18G 220 with adaptors 'A', 'D' and 'E'. The bearing and oil seal will be withdrawn with the hub.

### Section J.5

#### BEVEL PINION AND DIFFERENTIAL

##### Removing and Refitting Bevel Pinion Oil Seal

- (1) Mark the propeller shaft and the pinion driving flanges so that they may be replaced in the same relative position. Disconnect the propeller shaft.
- (2) Unscrew the nut in the centre of the driving flange. Remove the nut and washer and withdraw the flange and pressed-on end cover from the pinion shaft.
- (3) Extract the oil seal from the casing.
- (4) Press a new oil seal into the casing with the edge of the sealing ring facing inwards.

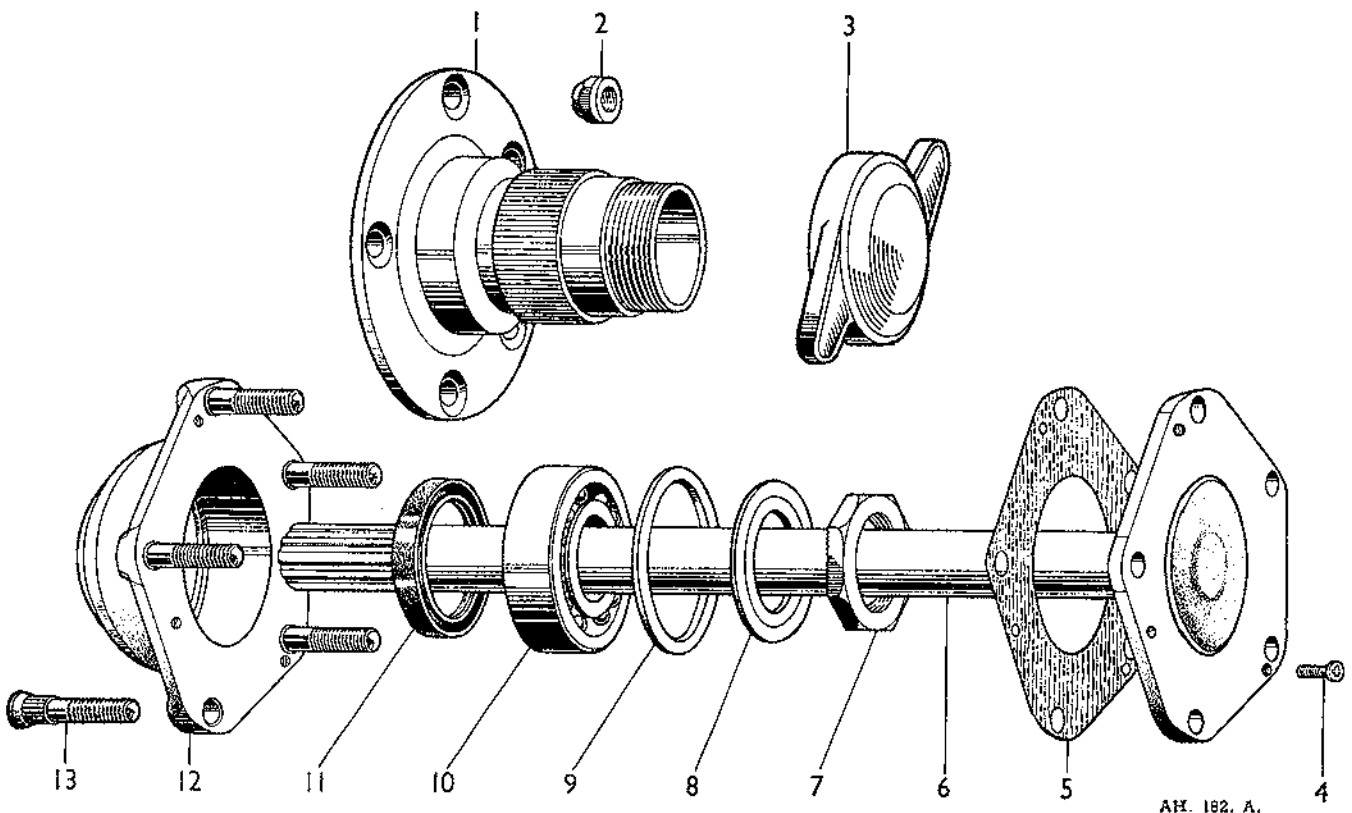

Fig. J.2. Rear axle hub assembly (with wire wheel hub extension).

- |                   |                         |                    |                  |
|-------------------|-------------------------|--------------------|------------------|
| 1. Hub extension. | 4. Securing nut.        | 7. Hub locknut.    | 10. Hub bearing. |
| 2. Securing nut.  | 5. Joint washer.        | 8. Hub lockwasher. | 11. Oil seal.    |
| 3. Hub cap.       | 6. Half shaft.          | 9. Bearing spacer. | 12. Hub casing.  |
|                   | 13. Hub extension stud. |                    |                  |



- (5) Replace the driving flange end cover, taking care not to damage the edge of the oil seal. Tighten the nut with a torque wrench to a reading of 1,680 lb. in. (19.36 kg. m.).
- (6) Reconnect the propeller shaft, taking care to fit the two flanges with the locating marks in alignment.

### Removing the Differential

- (1) Drain the oil from the axle casing, and remove the axle shafts.
- (2) Mark the propeller shaft and pinion shaft driving flanges so that they may be replaced in the same relative positions; unscrew the nuts and bolts and separate the joint.
- (3) Unscrew the twelve nuts securing the bevel pinion and gear carrier casing to the axle banjo; withdraw the casing complete with the pinion shaft and differential assembly.
- (4) Make sure that the differential bearing housing caps are marked so that they can be replaced in their original positions, then remove the four nuts and spring washers. Withdraw the bearing caps and differential assembly.

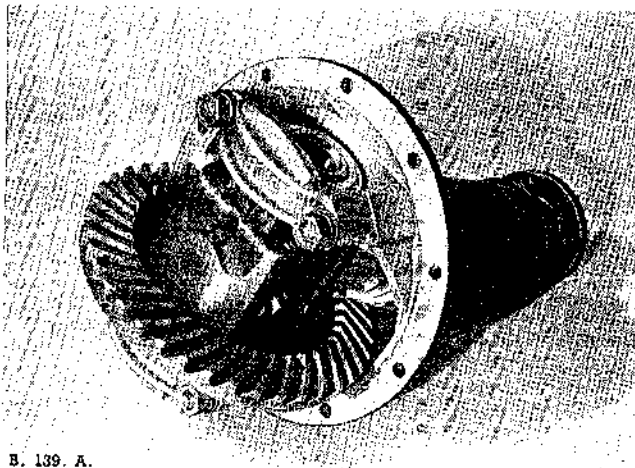

B. 139. A.

Fig. J.3. The differential carrier.

- (5) Remove the differential bearings from the differential case. Note that the word "Thrust" is stamped on the thrust face of each bearing and that shims are fitted between the inner ring of each bearing and the differential case.
- (6) Knock back the tabs of the locking washers, unscrew the nuts from the bolts securing the crown wheel to the differential, and remove the crown wheel.
- (7) Tap out the dowel pin locating the differential pinion shaft. The diameter of the pin is  $\frac{3}{16}$  in. (4.8 mm.). The pinions and thrust washers can then be removed from the case.

### Examination and Assembly

- (1) Examine the pinions and thrust washers and renew as required.
- (2) Examine the crown wheel teeth. If a new crown wheel is needed, a mated pair—pinion and crown wheel—must be fitted (see Section J.6).
- (3) Replace the pinions, thrust washers and pinion shaft in the differential casing and insert the dowel pin. Peen over the entry holes.
- (4) Bolt the crown wheel to the differential case, but do not knock over the locating tabs. Tighten the nuts to a torque wrench reading of 540 lb. ft. (6.2 kg. m.).
- (5) Mount the assembly on two "V" blocks and check the amount of run out of the crown wheel as it is rotated, by means of a suitably mounted dial indicator.

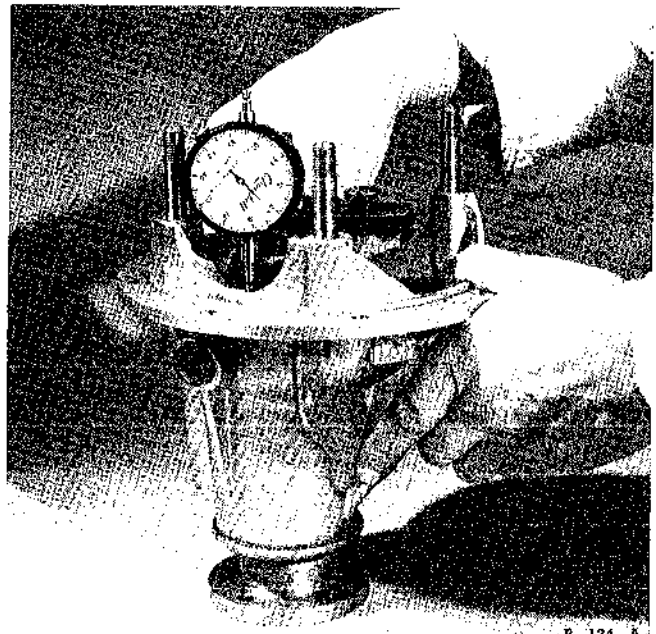

B. 134. A.

Fig. J.4. Gauging the depth of the differential bearing housings.

- (6) The maximum permissible run out is .002 in. (.05 mm.) and any greater irregularity must be corrected. Detach the crown wheel and examine the joint faces on the flange of the differential case and crown wheel for any particles of dirt.
- (7) When the parts are thoroughly cleaned it is unlikely that the crown wheel will not run true.
- (8) Tighten the bolts to the correct torque wrench reading and knock over the locking tabs.
- (9) Fit the differential bearings with the thrust faces outwards.

## REAR AXLE AND SUSPENSION

Fig. J.5. The rear axle exploded.

1. Breather.
2. Filler plug.
3. Axle casing.
4. Differential pinion shaft.
5. Drain plug.
6. Gear carrier stud.
7. Nut.
8. Differential wheel packing shim.
9. Differential wheel.
10. Differential pinion.
11. Pinion thrust washer.
12. Pinion shaft securing pin.
13. Lockwasher.
14. Crown wheel setpin.
15. Differential bearing cap.
16. Bearing collar.

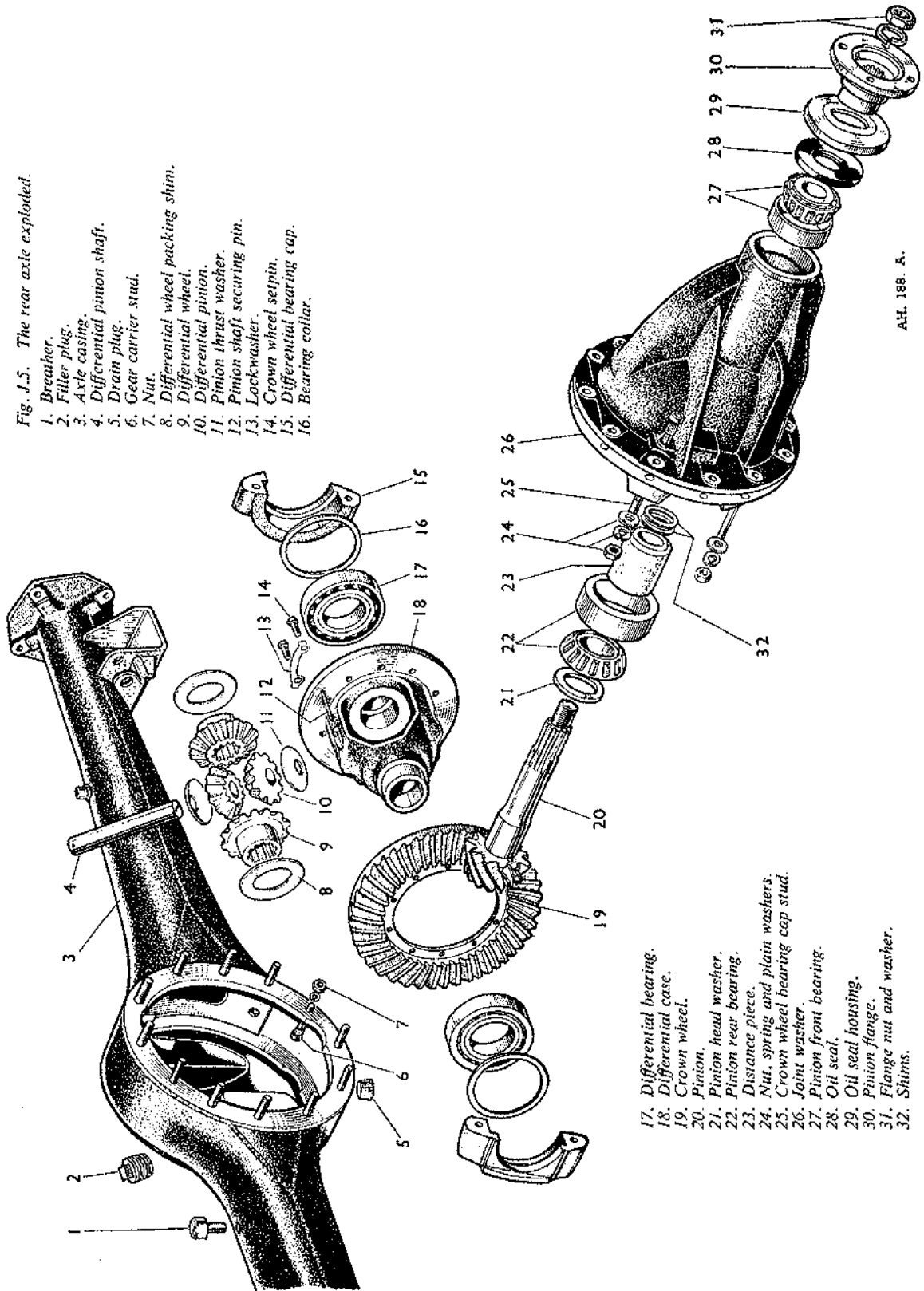

AH. 186. A.

17. Differential bearing.
18. Differential case.
19. Crown wheel.
20. Pinion.
21. Pinion head washer.
22. Pinion rear bearing.
23. Distance piece.
24. Nut, spring and plain washers.
25. Crown wheel bearing cap stud.
26. Joint washer.
27. Pinion front bearing.
28. Oil seal.
29. Oil seal housing.
30. Pinion flange.
31. Flange nut and washer.
32. Shims.

- (5) Remove the three eyebolt adjusting nuts, sheering away the peening by initial pressure.
- (6) Unscrew the setscrews securing the clutch cover to the base plate in a diagonal pattern, releasing the pressure on the clutch springs gradually and evenly. Lift off the cover and remove the pressure springs.
- (7) To remove the release levers, remove the anti-rattle springs, grasp the lever and eyebolt between the thumb and fingers, so that the inner end of the lever and the threaded end of the eyebolt are as near together as possible, keeping the eyebolt pin seated in its socket in the lever. The strut can then be lifted over the ridge onto the end of the lever, making it possible to lift the eyebolt off the pressure plate.
- (8) Clean the clutch parts carefully. If the linings are to be used again they should not be allowed to come in contact with cleaning fluids.
- (9) Examine the friction linings for wear or loose rivets and check the driven plate for uneven or worn splines, distortion or signs of fatigue cracks. Generally, it is not desirable to fit new friction linings on the original driven plate because refaced driven plates often are distorted or otherwise impaired and produce unsatisfactory clutch action. If renewing old worn linings, the rivets should be drilled out, not punched out.
- (10) After refacing, mount the driven plate on a mandrel between centres and check for "run-out" by means of a dial gauge, set as near to the edge as possible. Where the "run-out" exceeds .015 in. (.38 mm.), true the plate by prising it in the requisite direction after finding the high spots.
- (11) Examine the machined face of the pressure plate. If this is badly grooved and rough, the surface may be reground until the grooves disappear.
- (12) Examine the machined surface of the release lever plate. If this is badly grooved, renew the plate. A new plate will also be necessary if the surfaces on the reverse side of the plate, which are in contact with the tips of the release levers, are worn down.
- (13) Examine the tips of the release levers which bear on the back of the release lever plate. A small amount of worn flat surface is permissible, but if this is excessive the lever should be renewed. Check for excessive wear in the groove in which the strut bears. Examine carefully the "U"-shaped depression in the lever into which fits the eyebolt floating pin. If the metal here has worn at all thin, the lever must be renewed as there is a danger of it breaking under load with disastrous results to the whole clutch mechanism.

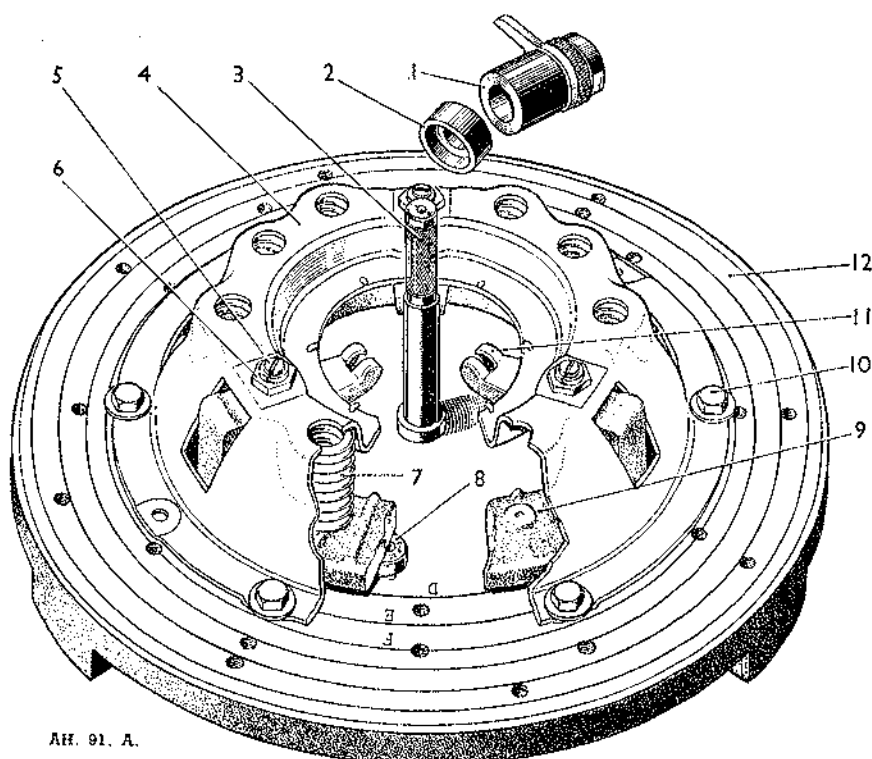

AH. 91. A.

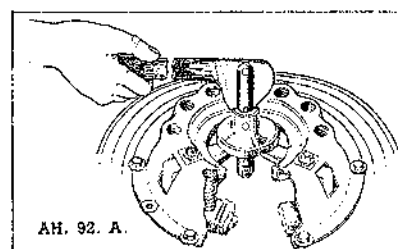

Fig. E.3. Clutch assembly tool.

1. Height finger.
2. Distance piece.
3. Centre pillar.
4. Clutch cover.
5. Eyebolt.
6. Eyebolt locknut.
7. Thrust spring.
8. Spacing washer.
9. Pressure plate.
10. Setscrew.
11. Release lever.
12. Base plate.

*Inset shows the clutch tool actuating mechanism in use.*

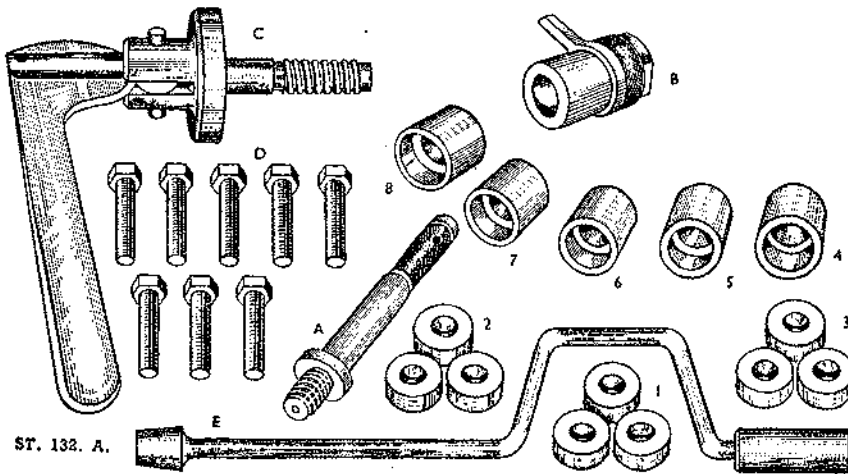

Fig. E.4. Parts of clutch assembly tool.

- A. Centre pillar.  
 B. Height finger.  
 C. Actuating mechanism.  
 D. Setpins.  
 E. Speedbrace.  
 1. } Spacing washers.  
 2. }  
 3. }  
 4. }  
 5. } Distance pieces.  
 6. }  
 7. }  
 8. }

- (14) Examine each eyebolt for flats on the surface which fits into the pressure plate. If it is a loose fit, it must be renewed. The same applies to the eyebolt floating pin where it passes through the eyebolt. It should be a free fit, but not too loose.
- (15) Examine the release bearing for cracks or bad pitting, also measure the amount of bearing standing proud of the metal cup. If the bearing is cracked or badly pitted, or there is  $\frac{1}{16}$  in. (1.6 mm.) or less of bearing standing proud of the cup, the cup and bearing must be renewed.
- (16) Examine the pressure springs for weakness or distortion and renew if necessary. Renew in sets only.
- (17) Examine the clutch withdrawal shaft for slackness in the bushes. Renew the bushes if necessary.

### To Reassemble

Before reassembly note the positions of the marked parts and make sure to replace them in their original locations to preserve balance, unless the parts have been renewed. Using Tool No. 18G 99A, proceed as follows :—

- (1) Position the pressure plate on the three spring washers on the base plate as described under "To Dismantle".
  - (2) Install the release lever, eyebolt and eyebolt pin, holding the threaded end of the eyebolt and the inner end of the lever as close together as possible. With the other hand insert the strut in the slots in the pressure plate sufficiently to allow the plain end of the eyebolt to be inserted in the hole provided in the pressure plate. Move the strut upwards into the slots in the pressure plate lug, over the ridge on the short end of the lever, and drop it into the groove formed in the lever. Fit the remaining release levers in a similar manner. A very slight smear of grease should be applied to the release lever pins, contact faces of the struts, eyebolt seats in the clutch cover, drive lug sides on the pressure plate and the plain end of the eyebolts.
  - (3) Place the pressure springs on the bosses on the pressure plate.
  - (4) Lower the cover over the assembled parts, ensuring that the anti-rattle springs are in position and that the tops of the pressure springs are directly under their seats in the cover. In addition the machined portions of the pressure plate lugs must be directly under the slots in the cover through which they will pass.
  - (5) Insert the tool setscrews through the cover holes and screw them into the base plate in a diagonal pattern, a little at a time, to prevent distortion. Guide the eyebolts and pressure plate lugs through the holes in the clutch cover during this gradual tightening down.
  - (6) Screw the adjusting nuts onto the eyebolts.
- The clutch must now be adjusted still using the clutch assembly tool. With the clutch bolted to the tool base plate as on completion of assembly, proceed as follows :—
- (7) Screw the actuator into the base plate and pump the handle a dozen times to settle the clutch mechanism. Remove the actuator.
  - (8) Screw the tool centre pillar into the base plate and select a distance-piece, Code No. 7, as shown on the chart. Place the distance-piece over the centre pillar with its recessed face downwards.
  - (9) Place the gauge height finger over the centre pillar.
  - (10) Adjust the height of the release levers by tightening or loosening the eyebolts until the height finger, when rotated, just contacts the highest point on the tips of the release levers. Press downwards on the height finger to ensure that it bears squarely on the adaptor while rotating.

- (11) Remove the height finger and pillar, and screw in the actuator to the base plate. Operate the clutch several times to enable the components to settle on their knife edges. Remove the actuator and replace the centre pillar, distance-piece and height finger. Readjust the release levers if necessary. Repeat the procedure to ensure that the release levers are finally seated, and gauge once more.
- (12) Remove the centre pillar, distance-piece and height finger and peen over the release lever adjusting nuts.
- (13) Fit the release lever plate on the tips of the release levers and secure it by the three retaining springs.
- (14) Release the tool setscrews in diagonal sequence a little at a time, relieving pressure slowly and evenly. Remove the clutch assembly from the base plate.

### To Replace

Before installing the clutch assembly the engine flywheel should be checked for misalignment (see Section A). To install the clutch proceed as follows :—

- (1) Hold the clutch cover assembly and driven plate on the flywheel and screw in the cover securing bolts finger-tight. Note that the splines in the hub of the driven plate are chamfered at one end to permit ready entry of the first motion shaft splines. The longer side of the driven plate hub, with the chamfered splines, should be toward the rear.
- (2) Insert a pilot shaft or an aligning arbor No. 18G 79, through the clutch cover and driven plate hub so that the pilot enters the spigot bearing in the rear end of the engine crankshaft. This will centralise the driven plate.

- (3) Tighten the clutch cover securing bolts a turn at a time in diagonal sequence to avoid distorting the cover.
- (4) Remove the pilot shaft or aligning arbor.
- (5) Install the gearbox (see Section F.).

## Section E.4

### CLUTCH PEDAL

#### To Remove

- (1) The clutch and brake pedal linkages are mounted in a common bracket and thus have to be released as a unit.
- (2) Inside the car disconnect the clutch and brake cylinder levers from their master cylinder push rods by removing the clevis pins.
- (3) Working under the bonnet unscrew the six securing setpins sufficiently to allow the clutch and brake pedal linkage bracket to be withdrawn from inside the car.
- (4) Release the clutch and brake pedal return springs.
- (5) Unscrew the nut securing the clutch and brake pedal shaft and withdraw the shaft to release the clutch and brake pedal levers together with their distance piece.
- (6) Inspect the lever bushes for wear and renew if necessary.

#### To Replace

Replacement is the reverse of the procedure "To Remove".

## Section E.5

### MASTER CYLINDER

#### Description

The master cylinder consists of an alloy body with a polished finish bore, and reservoir with cap. The inner assembly is made up of the push rod, dished washer, circlip, plunger, plunger seal, spring thimble, plunger return spring, valve spacer, spring washer, valve stem and valve seal. The open end of the cylinder is protected by a rubber dust cover.

#### Dismantling the Clutch Master Cylinder

- (1) Release the master cylinder push rod from the clutch pedal as described in Section E.4.
- (2) Disconnect the pressure pipe union from the cylinder and remove the securing bolts, then the master cylinder and fluid reservoir may be withdrawn complete from the car.
- (3) Remove the filler cap and drain out the fluid. Pull back the rubber dust cover and remove the circlip with a pair of long nosed pliers. The push rod and dished washer can then be removed.

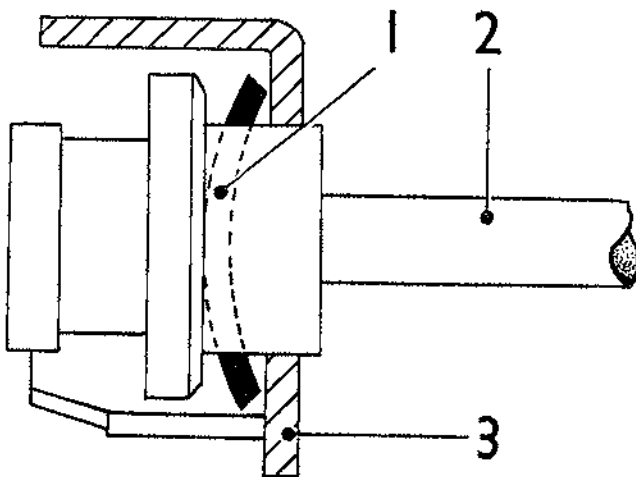

Fig. E.5. Further section of master cylinder.

1. Washer. 2. Valve stem. 3. Valve spacer.

- (4) When the push rod has been removed the plunger with seal attached will be exposed; remove the plunger assembly complete. The assembly can be separated by lifting the thimble leaf over the shouldered end of the plunger.
- (5) Depress the plunger return spring allowing the valve stem to slide through the elongated hole of the thimble thus releasing the tension on the spring.
- (6) Remove the thimble, spring and valve complete.
- (7) Detach the valve spacer, taking care not to lose the spacer spring washer which is located under the valve head. Remove the seal.
- (8) Examine all parts, especially the seals, for wear or distortion and replace with new parts where necessary.

### Assembling the Clutch Master Cylinder

- (1) Replace the valve seal so that the flat side is correctly seated on the valve head.
- (2) The spring washer should then be located with the dome side against the underside of the valve head, and held in position by the valve spacer, the legs of which face towards the valve seal.
- (3) Replace the plunger return spring centrally on the spacer, insert the thimble into the spring and depress until the valve stem engages through the

elongated hole of the thimble, making sure the stem is correctly located in the centre of the thimble. Check that the spring is still central on the spacer.

- (4) Refit a new plunger seal with the flat of the seal seated against the face of the plunger. Insert the reduced end of the plunger into the thimble until the thimble leaf engages under the shoulder of the plunger. Press home the thimble leaf.
- (5) Smear the assembly with the recommended brake fluid, and insert the assembly into the bore of the cylinder valve, end first, easing the plunger seal lips in the bore.
- (6) Replace the push rod with the dished side of the washer under the spherical head, into the cylinder followed by the circlip which engages into the groove machined in the cylinder body.
- (7) Replace the rubber dust cover and refit the whole unit into its aperture in the scuttle, not forgetting to fit the packing washer first. Secure the unit by means of the two bolts on the flange and refit the pressure pipe union into the cylinder.
- (8) Reconnect the push rod fork with its corresponding hole in the clutch pedal lever, securing it with the circlip.
- (9) If no further maintenance to the clutch is necessary, remember to bleed the system.

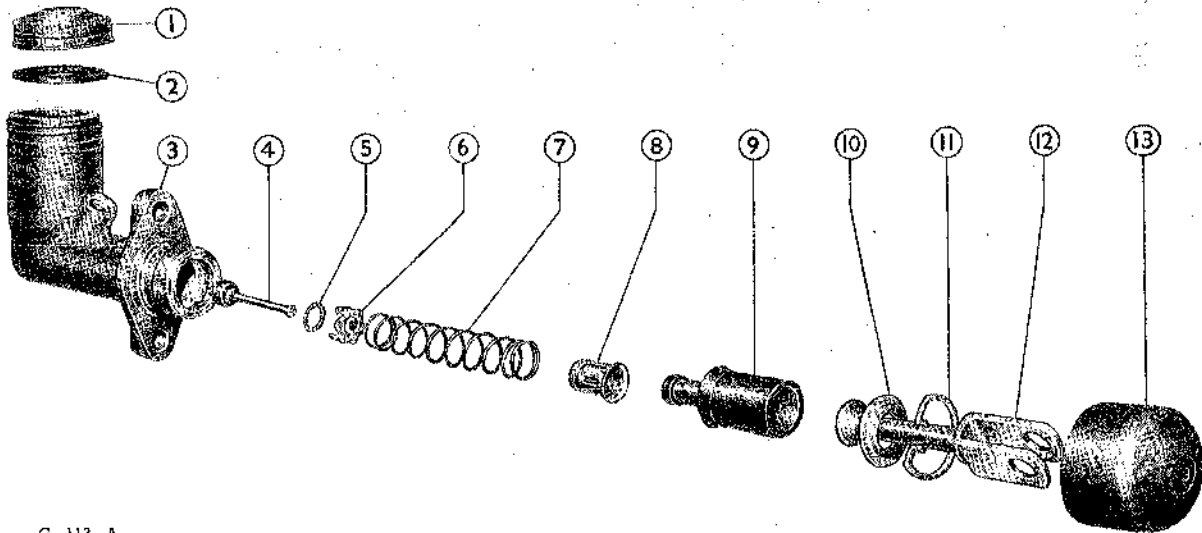

G. 113. A.

Fig. E.6. Components of master cylinder and reservoir.

- |                     |                   |                    |
|---------------------|-------------------|--------------------|
| 1. Filter cap.      | 5. Spring washer. | 10. Dished washer. |
| 2. Washer.          | 6. Valve spacer.  | 11. Circlip.       |
| 3. Master cylinder. | 7. Return spring. | 12. Fork.          |
| 4. Valve stem.      | 8. Thimble.       | 13. Dust cover.    |
|                     | 9. Plunger.       |                    |

## Section E.6

### SLAVE CYLINDER

#### Description

The cylinder is bolted to the clutch housing and comprises a piston, rubber cup, cup filler, spring, push-rod and bleeder screw. Fluid from the master cylinder is delivered through a flexible hose leading from a union in a bracket on the longitudinal member.

#### To Remove

- (1) Place a receptacle to catch the fluid and remove the flexible hose from the slave cylinder. Note that the thicker washer on the hose connection is nearest the cylinder.
- (2) Remove the split pin and clevis pin from the clutch withdrawal lever jaw end, thus freeing the slave cylinder push rod.
- (3) Remove the two bolts and spring washers securing the cylinder to the clutch housing.

#### To Dismantle

- (1) Remove all dirt from the outside of the cylinder.
- (2) Remove the rubber dust cap from the bleed nipple, attach a bleed tube, open the bleed screw three-quarters of a turn and pump the clutch pedal until all the fluid has been drained into a clean container.
- (3) Unscrew the pressure pipe union at the cylinder and remove the setpins from the flange. The slave cylinder can now be removed.
- (4) Remove the rubber cover and if an air line is available, blow out the piston and seal. The spring can also be removed.
- (5) Clean the slave cylinder components, **using only hydraulic fluid or alcohol**. The main casting may be cleaned with any of the normal cleaning fluids, but all traces of the cleaning fluid must be dried out.

- (6) Dry off and examine all rubber components and renew them if they are swollen, distorted or split. If there is any doubt at all as to their condition they must be renewed.
- (7) Inspect the piston and cylinder bore for wear and scores, and renew them as necessary.

#### Assembling the Slave Cylinder

- (1) Place the seal into the stem of the piston, with the back of the seal against the piston.
- (2) Replace the springs with the small end on the stem, smear well with the recommended fluid and insert into the cylinder.
- (3) Replace the rubber dust cover and mount the cylinder in position, making sure the push rod enters the hole in the rubber boot.

#### To Replace

- (1) Secure the cylinder to the clutch housing, and screw in the pipe union.
- (2) Bleed the clutch hydraulic system as described in Section E.7.

## Section E.7

### BLEEDING THE CLUTCH SYSTEM

- (1) Remove the bleed screw dust cap at the slave cylinder, open the bleed screw approximately three-quarters of a turn and attach a tube immersing the open end into a clean receptacle containing a small amount of brake fluid.
- (2) Fill the master cylinder reservoir with the recommended fluid and by using slow, full strokes, pump the clutch pedal until the fluid entering the container is free from air bubbles.
- (3) On a down stroke of the pedal, screw up the bleed screw, remove the bleed tube and replace the dust cap.

# E

## CLUTCH

### Section E.8

### FAULT DIAGNOSIS

Symptom	No.	Possible Fault
(a) Drag or Spin	1	Oil or grease on driven plate linings
	2	Bent engine backplate
	3	Misalignment between engine and first motion shaft
	4	Leaking operating cylinder, pipe line or air in system
	5	Driven plate hub binding on first motion shaft splines
	6	First motion shaft binding on its spigot bush
	7	Distorted clutch plate
	8	Warped or damaged pressure plate or clutch cover
	9	Broken clutch plate linings
	10	Dirt or foreign matter in clutch
(b) Fierceness or Snatch	1	Check 1, 2 and 3 in (a)
	2	Check 4 in (a) Worn clutch linings
(c) Slip	1	Check 1, 2 and 3 in (a)
	2	Check 1 in (b) Weak thrust springs Weak anti-rattle springs
(d) Judder	1	Check 1, 2 and 3 in (a)
	2	Pressure plate out of parallel with flywheel face
	3	Friction facing contact area not evenly distributed
	4	Bent first motion shaft
	5	Buckled driven plate
	6	Faulty engine or gearbox rubber mountings
	7	Worn shackles
	8	Weak rear springs
	9	Propeller shaft bolts loose Loose rear spring clips
(e) Rattle	1	Check 3 in (d)
	2	Damaged driven plate, <i>i.e.</i> broken springs, etc.
	3	Worn parts of release mechanism
	4	Excessive transmission backlash
	5	Wear in transmission bearings Release bearing loose on fork
(f) Tick or Knock	1	Worn first motion shaft bush
	2	Badly worn centre plate hub splines
	3	Out of line thrust plate
	4	Faulty bendix drive on starter
	5	Loose flywheel
(g) Driven Plate Fracture	1	Check 2 and 3 in (a) Drag and metal fatigue due to hanging gearbox in driven plate







# **SECTION F**

## **GEARBOX**

Section No. F.1	Description
Section No. F.2	Lubrication
Section No. F.3	Removal and replacement
Section No. F.4	Dismantling
Section No. F.5	Dismantling the mainshaft
Section No. F.6	Reassembly
Section No. F.7	Fault diagnosis

---



## Section F.1

### DESCRIPTION

The gearbox has four forward speeds and one reverse, and synchromesh is incorporated on second, third and top gears.

Top gear is a direct drive; third and second are in constant mesh; first and reverse are obtained by sliding spur pinions.

## Section F.2

### LUBRICATION

The gearbox oil level should be checked by the dipstick every 1,000 miles (1500 km.) and topped up if necessary.

The filler plug, which incorporates the dipstick, is located beneath a rubber cover, and is accessible when the floor mat and rubber cover have been raised.

After the first 500 miles the gearbox and overdrive, if fitted, should be drained and refilled with fresh oil. This procedure should be repeated afterwards every 6,000 miles (10000 km.).

Drain plugs are provided in the base of the gearbox and overdrive. Ensure that the hollow centre of the gearbox drain plug is kept clean. Do not forget to replace the plugs after draining.

The capacity of the gearbox is 4 pints (4.8 U.S. pints, 2.27 litres), plus an extra 1½ pints (1.53 U.S. pints, .710 litres) if overdrive gearbox is fitted.

## Section F.3

### REMOVAL AND REPLACEMENT

- (1) Turn the battery master switch, which is situated inside the luggage compartment, to the "off" position.
- (2) Inside the car remove the seat cushions and release the clips securing the padded arm rest to the central tunnel.
- (3) Unclip and roll back the carpet over the short gearbox tunnel to expose the twelve screws securing the tunnel to the body of the car. Unscrew the setscrews and remove the tunnel and its carpeting.
- (4) Unscrew the six setscrews, three on either side, which secure the carpet covered bulkhead and remove the bulkhead.
- (5) Using a suitable tool tap back the locking washer on the propeller shaft flange bolts and remove the bolts.
- (6) Unscrew the four setpins from the gearbox mounting brackets (see Fig. A.3, Section A), also unscrew the speedometer cable at its connection to the gearbox.

**Note.**—When an overdrive gearbox is fitted it will also be necessary to unclip the cable to the gearbox switch and release it at its terminal on the switch.

- (7) Working beneath the vehicle remove setpins (1) Fig. A.4, Section A, and unscrew the nuts (2) and (3) to release the stabiliser bar.
- (8) Detach the clutch slave cylinder from the gearbox bell housing by removing the two securing setpins. The slave cylinder push rod is released from the clutch operating lever by the removal of the securing clevis pin.
- (9) Remove the starter motor as described in Section N.
- (10) Place suitable supports underneath the gearbox bell housing and engine sump, and unscrew the nuts, bolts and setpins securing the bell housing to the engine backplate.
- (11) Withdraw the gearbox first motion shaft from the flywheel bearing and clutch by gently easing the gearbox rearwards.  
If the unit does not detach itself readily it will be necessary to raise the rear of the engine.
- (12) The replacement of the gearbox is a reversal of the removal procedure.

## Section F.4

### DISMANTLING

- (1) Remove the dipstick. Unscrew the breather from the overdrive unit, if fitted. Drain the oil from the gearbox and overdrive by removing the drain plug beneath each unit.
- (2) Unscrew the speedometer drive from the right-hand side of the rear extension.
- (3) Unscrew the seven short and one long bolt and remove the clutch housing.
- (4) Remove the three nuts threaded on studs mounted on the gear lever cup. With the removal of these nuts the cup may be withdrawn together with the three washers and three distance pieces located on the studs.
- (5) Withdraw the gear lever from the gearbox.
- (6) Unscrew the thirteen bolts securing the side cover to the gearbox housing and remove the cover; there are two dowels locating the cover. Take care not to lose the three selector balls and springs which will be released as the cover is withdrawn.
- (7) Unscrew the eight bolts and remove the rear extension.

**Note.**—For models fitted with overdrive.

Once the overdrive unit has been separated from the gearbox (see Section G), the removal of the

## GEARBOX

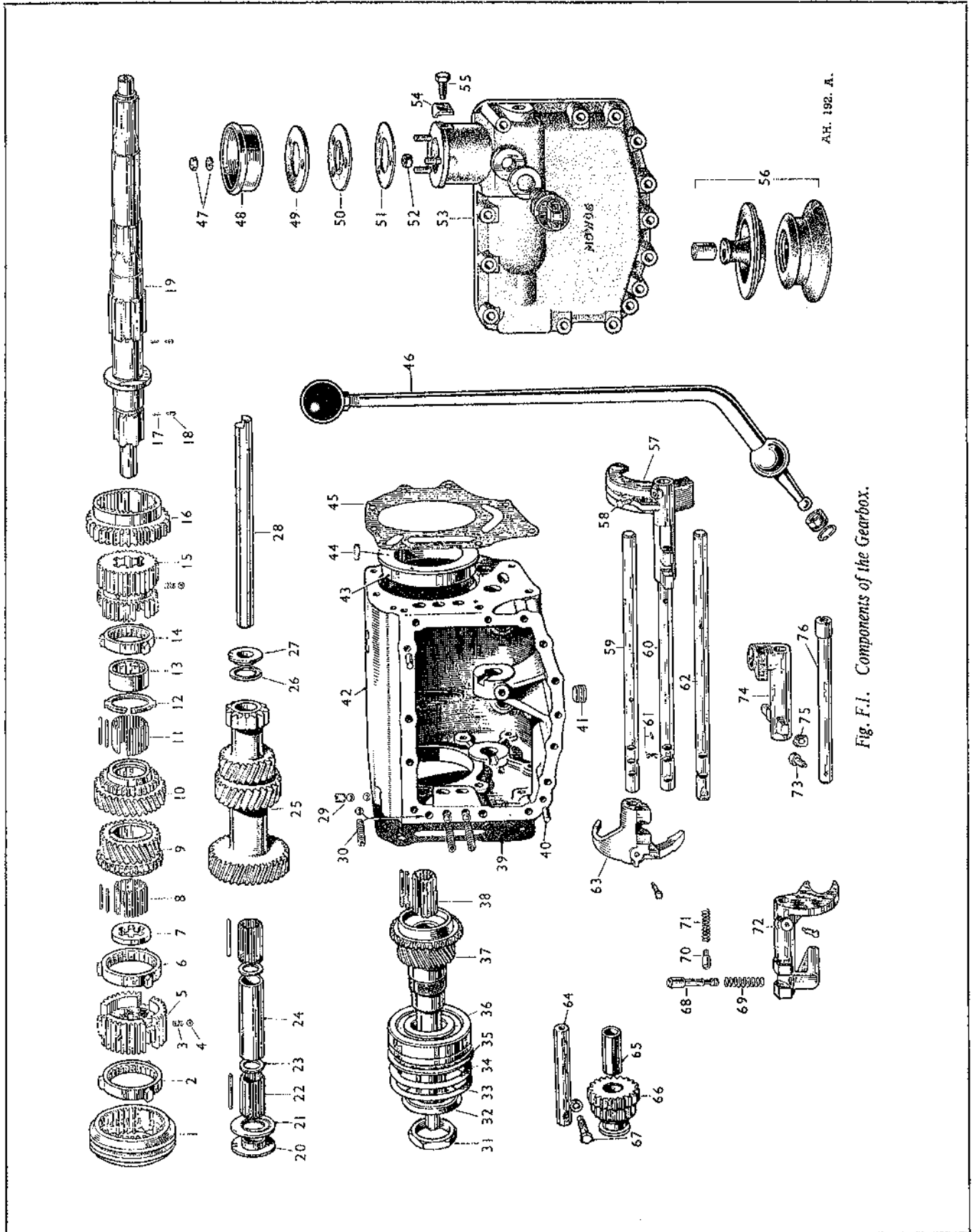

A.H. 192. A.

Fig. F.1. Components of the Gearbox.

*Fig. F.1. Components of the Gearbox.*

<ol style="list-style-type: none"> <li>1. Synchronesh sleeve.</li> <li>2. Baulking ring.</li> <li>3. Synchronizer spring.</li> <li>4. Synchronizer ball.</li> <li>5. 3rd and 4th speed synchronizer.</li> <li>6. Baulking ring.</li> <li>7. Locking plate.</li> <li>8. Needle rollers.</li> <li>9. Third speed gear.</li> <li>10. Second speed gear.</li> <li>11. Needle rollers.</li> <li>12. Gear washer.</li> <li>13. Locking plate.</li> <li>14. Baulking ring.</li> <li>15. 2nd speed synchronizer.</li> <li>16. First speed gear.</li> <li>17. Plunger spring.</li> <li>18. Gear plunger.</li> <li>19. Main shaft.</li> <li>20. Thrust plate.</li> <li>21. Thrust washer.</li> <li>22. Needle rollers.</li> <li>23. Washer, roller.</li> <li>24. Spacer, roller.</li> <li>25. Laygear.</li> </ol>	<ol style="list-style-type: none"> <li>26. Washer.</li> <li>27. Thrust plate.</li> <li>28. Layshaft.</li> <li>29. Interlocking balls.</li> <li>30. Selector ball and spring.</li> <li>31. Bearing nut.</li> <li>32. Bearing nut lockwasher.</li> <li>33. Bearing spring plate.</li> <li>34. Bearing plate.</li> <li>35. Bearing circlip.</li> <li>36. First motion shaft bearing.</li> <li>37. First motion shaft.</li> <li>38. Needle rollers.</li> <li>39. Joint washer.</li> <li>40. Side cover dowel.</li> <li>41. Drain plug.</li> <li>42. Gearbox casing.</li> <li>43. Bearing housing.</li> <li>44. Locating peg.</li> <li>45. Joint washer.</li> <li>46. Gear lever.</li> <li>47. Nut and washer.</li> <li>48. Cup.</li> <li>49. Rubber washer (thick).</li> <li>50. Steel washer.</li> <li>51. Rubber washer (thin).</li> </ol>	<ol style="list-style-type: none"> <li>52. Distance piece.</li> <li>53. Side cover.</li> <li>54. Washer.</li> <li>55. Gear lever locating screw.</li> <li>56. Rubber dust covers.</li> <li>57. 1st and 2nd speed fork.</li> <li>58. Screw for fork.</li> <li>59. 3rd and 4th speed fork rod.</li> <li>60. 1st and 2nd speed fork rod.</li> <li>61. Interlocking pin and rivet.</li> <li>62. Reverse fork rod.</li> <li>63. 3rd and 4th speed fork.</li> <li>64. Reverse shaft.</li> <li>65. Bush.</li> <li>66. Reverse gear.</li> <li>67. Locking screw.</li> <li>68. Selector plunger.</li> <li>69. Selector plunger spring.</li> <li>70. Detent plunger.</li> <li>71. Detent plunger spring.</li> <li>72. Reverse fork.</li> <li>73. Control shaft locating screw.</li> <li>74. Locking washer.</li> <li>75. Control shaft.</li> <li>76. Control lever.</li> </ol>
---	--	--

adaptor plate is accomplished by unscrewing the eight setpins mounted in the recess in the adaptor plate.

The overdrive pump cam should slide freely along the third motion shaft thus giving access to the circlip holding the distance piece to the rear adaptor plate. Remove the circlip and slide the distance piece off the shaft. The adapter plate should now pull away from the gearbox, together with the rear main bearing. It may be necessary for one operator to hold the gearbox vertically by the adapter plate whilst a second operator taps the third motion shaft until the ball race in the adapter plate is free of the shaft.

- (8) Cut the locking wires and unscrew the fork retaining screws. Remove the shifter shafts and forks in the following order :—
  - (a) The reverse shaft and fork together with its selector and detent plungers and springs.
  - (b) Top gear shifter shaft only.
  - (c) First and second shaft and fork.
  - (d) Top gear fork.

Take care not to lose the two interlock balls, normally located one at each side of the centre shifter shaft, which will be released when the shaft is removed.

- (9) Unscrew the reverse shaft locating screw and push out the shaft; lift the gear from the box.
- (10) Tap out the layshaft and allow the gear to rest in the bottom of the box.
- (11) Withdraw the first motion shaft assembly; note that there are 16 spigot rollers.
- (12) Withdraw the mainshaft rearwards.
- (13) Lift out the layshaft gear and thrust washers.

## Section F.5

### DISMANTLING THE MAINSHAFT

- (1) Slide the top and third gear hub and interceptors from the forward end.
- (2) Depress the plunger locating the third gear locking plate, rotate the plate to line up the splines and slide it from the shaft. Extract the plunger and spring, and slide off the third speed gear and its 32 rollers.
- (3) Unscrew the main shaft nut; remove the nut, locking washer, speedometer drive gear, bearing with housing and distance collar.
- (4) Slide the first and second speed hub, second speed interceptor and first speed gear rearwards from the shaft; if the first speed gear is withdrawn from the hub, take care to hold the balls and springs located in holes in the hub.
- (5) Depress the second gear locking collar plunger and rotate the collar to line up the splines; slide the collar from the shaft and extract the two halves of the second gear washer, retaining the spring and plunger.
- (6) Withdraw the second speed gear and its 33 rollers from the shaft.
- (7) To dismantle the first motion shaft assembly, tap up the locking tab, unscrew the nut and remove the bearing.

**Note.**—The method of dismantling and reassembling the overdrive gearbox is the same as that described for the standard gearbox, with the exception that no speedometer drive gear or locking washer and nut is fitted.

# F

## GEARBOX

### Section F.6

#### REASSEMBLY

##### Mainshaft

- (1) Smear the shaft with grease and assemble the 33 second speed gear rollers; slide the second gear into position.
- (2) Replace the plunger and spring. Fit the two halves of the second gear washer and slide the collar on to the splines. Depress the plunger and push the collar into position, locating the lugs of the washer in the cut-outs of the collar; rotate the collar to bring the splines out of line.
- (3) Replace the balls and springs in the second and first speed hub; depress the balls and slide the first speed gear on to the hub; refit the assembly to the shaft.
- (4) Refit the bearing distance collar, the bearing and housing, the speedometer drive gear key and gear, locking washer and nut. Tighten the nut and tap over the locking washer.
- (5) Fit the third gear and its 32 rollers to the shaft; replace the plunger and spring and the third speed locking plate; rotate the plate to bring the splines out of line.
- (6) Fit the balls and springs to the top and third speed hub and slide the striking dog into position on the hub.
- (7) Replace the hub, striking dog and interceptors on the shaft.

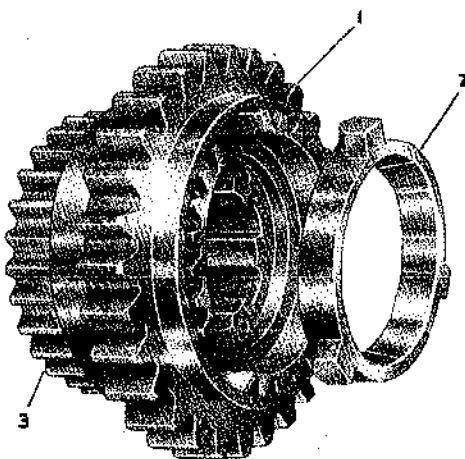

G. 127. A.

Fig. F.2. Assembling gear and synchronizer.

1. Gear. 2. Baulking ring. 3. Synchronizer.

F.4

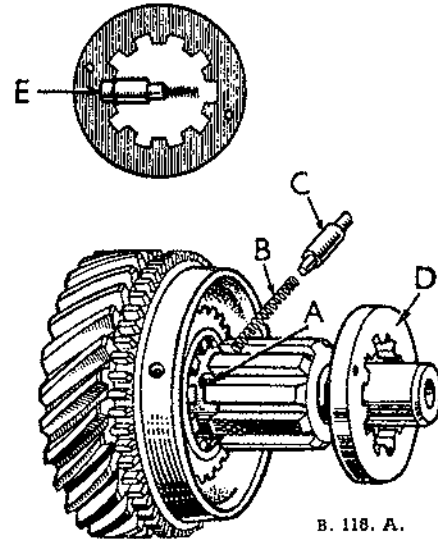

Fig. F.3. Securing the third motion shaft gears.  
A. Hole for spring. C. Location peg.  
B. Spring. D. Locking washer.  
E. Peg located in washer.

##### Layshaft

- (1) Fit the distance tube to the layshaft gear with a washer at each end of the tube.
- (2) Smear the rollers with grease and position them in the gear. Place the thrust washers and plates in position at each end of the gear.
- (3) To retain the rollers in position, a length of round bar of layshaft diameter and just long enough to hold the thrust washers and plates, should be inserted in the gear assembly.
- (4) Place the gear in the box and allow it to rest at the bottom.

##### Gearbox

- (1) Insert the mainshaft assembly from the rear of the box.
- (2) Position the first motion shaft rollers and the first motion shaft assembly in the box.
- (3) Lift the layshaft gear into position, locating the thrust washer tags in the grooves provided. Push the layshaft through the housing and gear, and withdraw the retaining bar as the shaft pushes it out of the gear. The cut-away portion of the shaft must be aligned to fit the groove in the bell housing provided to prevent the layshaft from turning.
- (4) Refit the reverse gear and shaft and tighten the setscrew. Place the top gear shifter fork in the box. Replace the first and second gear shifter fork and shaft.
- (5) Replace one interlock ball above the first and second shifter shaft and insert the top gear shifter shaft.



- (6) Position the remaining interlock ball, holding it with grease and refit the reverse fork and shaft together with its selector and detent plungers and springs.
- (7) Screw in the fork setscrews, tighten up and wire.
- (8) Bolt the rear extension into position, using a new gasket if necessary. Note that the plain bearing plate is fitted against the bearing.

**Note.**—For models fitted with overdrive :—

Slide the adapter plate, together with its bearing and paper joint washer, along the third motion shaft. Fit and tighten down the eight setpins securing the adapter plate to the gearbox.

Fit the distance piece which covers the space

- between the rear main bearing and the groove allocated for the circlip, and fix on the latter.
- (9) Refit the selector balls to the holes in the gearbox housing and the springs in the holes in the side cover.
- (10) The gear lever together with its cup, washers and distance pieces may now be attached to the side cover. Ensure that the ball of the lever makes a good fit with its mating socket.
- (11) Refit the cover, fitting a new gasket as required. Observe that the top right-hand setpin is longer than the other twelve.
- (12) Refit the clutch housing with plain bearing plate against the bearing.  
Refit the speedometer drive, breather and dipstick.

## Section F.7

## FAULT DIAGNOSIS

Symptom	No.	Possible Fault
(a) Jumping out of Gear	1	Broken change speed fork rod spring
	2	Excessively worn fork rod groove
	3	Worn coupling dogs
	4	Fork rod securing screw loose
(b) Noisy Gearbox	1	Insufficient oil in gearbox
	2	Excessive end play in laygear
	3	Damaged or worn bearings
	4	Damaged or worn teeth
(c) Difficulty in Engaging Gear	1	Incorrect clutch pedal adjustment
(d) Oil Leaks	1	Damaged joint washers
	2	Damaged or worn oil seals
	3	Front, rear or side covers loose or damaged



# **SECTION G**

## **OVERDRIVE**

Section No. G.1	Lubrication
Section No. G.2	Working description
Section No. G.3	Construction
Section No. G.4	Servicing in position
Section No. G.5	Guide to service diagnosis
Section No. G.6	Operating valve
Section No. G.7	Hydraulic system
Section No. G.8	Pump valve
Section No. G.9	Hydraulic pressure
Section No. G.10	Dismantling and reassembling unit
Section No. G.11	Overdrive relay system
Section No. G.12	Fault tracing

---



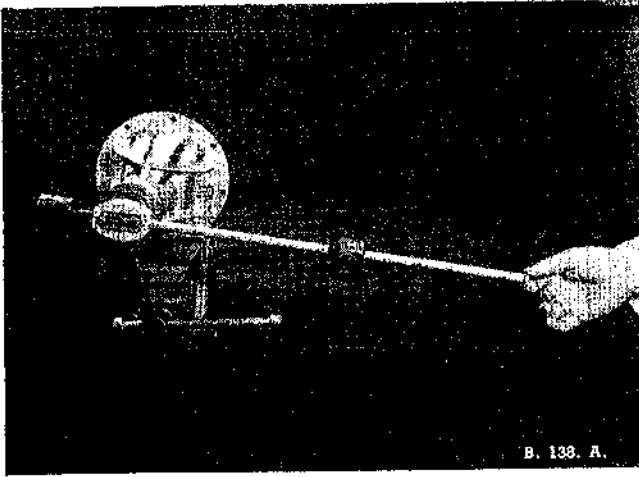

Fig. J.6. Checking the bevel pinion bearing pre-load (Service Tool No. 18G 207).

## The Pinion Shaft

- (1) Remove the differential assembly. Unscrew the nut ; remove the spring washer, the driving flange and the pressed end cover.
- (2) Drive the pinion shaft towards the rear ; it will carry with it the inner race and the rollers of the rear bearing, leaving the outer race and the complete front bearing in position.
- (3) The inner race of the front bearing may be removed with the fingers after removal of the oil seal, and the outer race may be withdrawn with Service Tool No. 18G 264 with adaptors 'D' and 'H'.
- (4) Slide off the pinion sleeve and shims ; withdraw the rear bearing inner race from the pinion shaft, noting the spacing washer against the pinion head.

## Section J.6

### CROWN WHEEL AND PINION

#### Replacing Crown Wheel and Pinion

Fitting a new crown wheel and pinion involves four distinct operations :—

- (1) Setting the position of the pinion.
- (2) Adjusting the pinion bearing pre-load.
- (3) Adjusting the differential bearing pre-load.
- (4) Adjusting the backlash between the gears.

To carry out these operations correctly, three special tools are required; the bevel pinion setting gauge, Service Tool No. 18G 191, the pinion bearing outer race remover and replacer, Service Tool No. 18G 264 and the pre-load checking tool, Service Tool No. 18G 207.

#### Setting the Pinion Position

- (1) Fit the bearing outer races to the gear carrier.
- (2) Smooth off the pinion head with an oil stone, but do not erase the variation in pinion head thickness that is etched on the pinion head.
- (3) Refit the pinion head washer; if the original washer is damaged or not available, select a washer from the middle of the range of thicknesses: say, .214 in. or .216 in.
- (4) Fit the inner race of the rear bearing to the pinion shaft and position the pinion in the gear carrier without the shims, distance tube and oil seal. Fit the inner race of the front bearing.
- (5) Refit the universal joint driving flange and tighten the nut gradually until a pre-load figure of 16 to 18 in. lb. (.184 to .207 kg. m.) is obtained.
- (6) Adjust the dial indicator to zero on the machined step "C" of the setting block (Service Tool No. 18G 191).
- (7) Remove the keep disc from the base of the magnet; clean the pinion head and place the magnet and dial indicator in position (fig. J.4). Move the indicator arm until the foot of the gauge rests on the centre of the differential bearing bore at one side and tighten the knurled locking screw. Obtain the maximum depth reading and note any variation from the zero setting.  
Repeat the check in the opposite bearing bore. Add the two variations together and divide by two to obtain a mean reading.

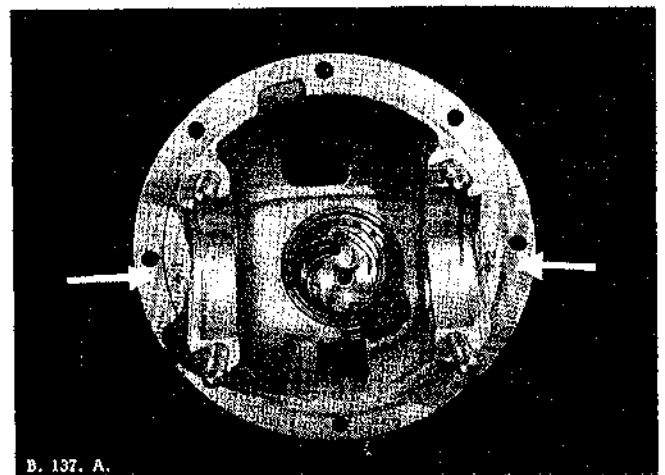

Fig. J.7. Illustrating the machining tolerances for the differential bearing housings as marked by the factory inspector.

(8) *With a standard pinion head (no variation marked).*

If the mean reading is within  $\pm 0.001$  in. ( $0.025$  mm.) of the zero setting, the washer thickness is correct.

A positive mean reading indicates that the washer is not thick enough, and a negative mean reading indicates that it is too thick.

*Example:* Thickness of washer fitted ...  $0.214$  in.  
 Mean reading ...  $\pm 0.003$  in.  
 Thickness of washer required ...  $0.217$  in.

(9) *With a non-standard pinion head (variation marked).*

In addition to the procedure detailed above, allowance must also be made for the variation in thickness of the pinion head; a positive (+) dimension must be subtracted from the thickness obtained above, and a negative (-) dimension added.

Using the same example and assuming a pinion head of non-standard thickness :

*Example:* Thickness of washer fitted ...  $0.214$  in.  
 Mean reading ...  $\pm 0.003$  in.  
 Total ...  $0.217$  in.  
 Marked variation pinion head thickness ...  $\pm 0.002$  in.  
 Thickness of washer required ...  $0.215$  in.

A tolerance of  $0.001$  in. is allowed in the thickness of the washer finally fitted.

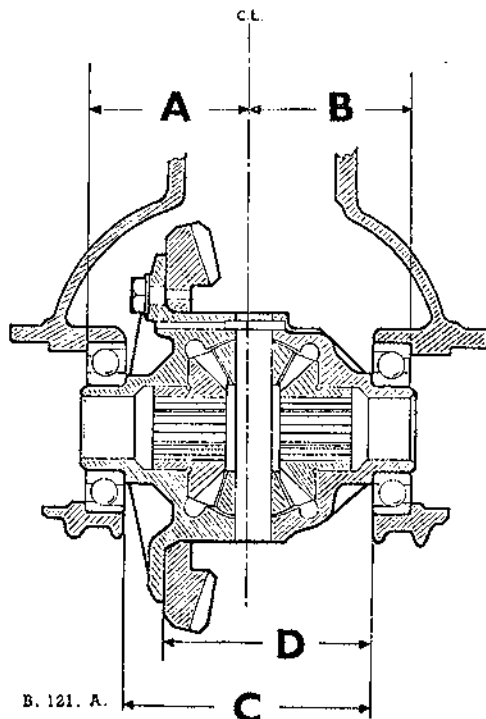

B. 121. A.

Fig. J.8. Illustrates the points from which the calculations must be made to determine the shim thickness for the bearings on each side of the carrier.

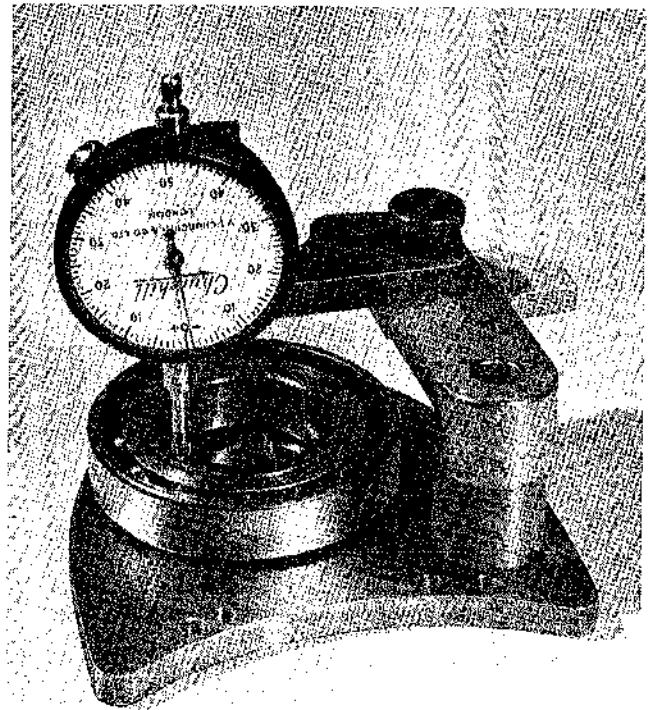

B. 135. A.

Fig. J.9. Checking differential bearing width with Service Tool No. 18G 191B.

### Adjusting Pinion Bearing Pre-load

- (1) Assemble the pinion shaft bearings, distance tube, and shims to the gear carrier; fit the oil seal and driving flange.
- (2) Tighten the flange nut gradually to a torque wrench reading of  $1,680$  lb. in. ( $19.4$  kg.m.), checking the pre-load at intervals to ensure that it does not exceed  $21$  lb. in., i.e.  $3$  lb. in. greater than the previous figure as the oil seal is now fitted.
- (3) If the pre-load is too great more shims must be added, and if too small the thickness of the shimming must be decreased.

### Adjusting the Differential Bearing Pre-load

**Units marked with tolerances:** The differential bearings must be pre-loaded and this is done by "pinching" them to the extent of  $0.002$  in. on each bearing, the "pinch" being obtained by varying the thickness of the bearing distance collar fitted between each bearing outer ring and the register in the axle housing. The collar thickness is calculated as shown below.

In making the necessary calculations, machining tolerances and variations in bearing width must be taken into account. Machining tolerances are stamped on the component: bearing width variations must be measured.

The dimensions involved in pre-loading the differential bearings are illustrated in fig. J.8, and it is

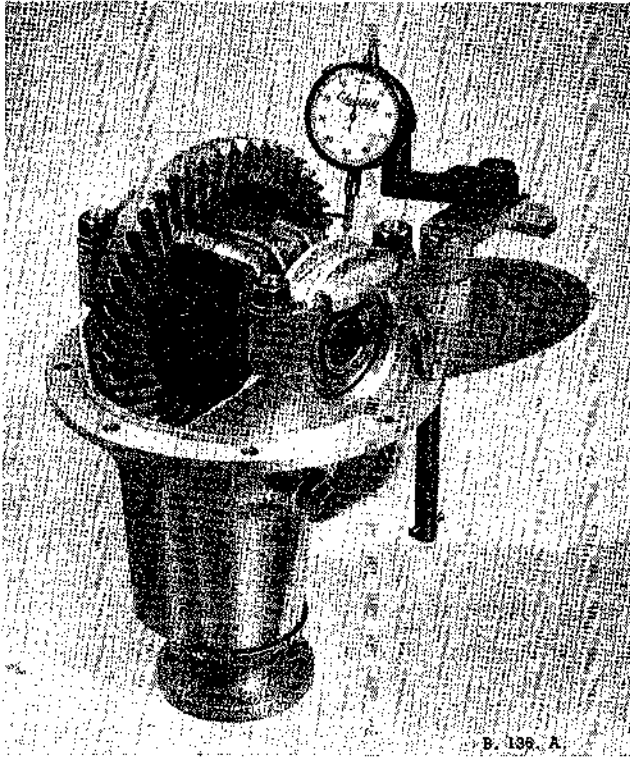

Fig. J.10. Checking crown wheel to pinion backlash (Service Tool No. 18G 191B).

emphasised that it is the tolerance on each dimension which is important and referred to in the formula used.

The dimensions are :—

- (1) From the centre line of the differential to the bearing register on the left-hand side of the gear carrier.  
Tolerance: stamped on the carrier.
- (2) From the centre line of the differential to the bearing register on the right-hand side of the carrier.  
Tolerance: stamped on the carrier.
- (3) From the bearing register on one side of the differential cage to the register on the opposite side.  
Tolerance: stamped on the cage.
- (4) From the rear face of the crown wheel to the bearing register on the opposite side.  
Tolerance: stamped on the cage.

To calculate the collar thickness :—

*Left-hand side:*

Formula:  $A + D - C \div .1815$  in. (4.610 mm.).

Substitute the dimensional tolerances for the letters in the formula. The result is the thickness of the collar required at the left-hand side to compensate for machining tolerances and to give the necessary pinch, with bearings of standard width. The width of the bearing must now be checked and any variation from

standard added to or subtracted from the collar thickness. If the bearing width is under standard, that amount must be added to the collar thickness, and vice versa.

Table of Washer and Shim Thickness

Pinion head washer thicknesses	... .. .	.208 in. to .222 in. in steps of .002 in.
Pinion bearing shims	... .. .	.004 in. to .012 in. in steps of .002 in., plus .020 in. and .030 in.
Crown wheel bearing collars	... .. .	.175 in. to .185 in. in steps of .002 in.
Pinion bearing pre-load	... .. .	16 to 18 lb. in. without oil seal; 19 to 21 lb. in. with oil seal.
Crown wheel bearing pinch	... .. .	.002 in. each side.

### To Check Bearing Width

- (1) Rest the bearing on the small surface plate of Tool No. 18G 191B with the inner race over the recess and the thrust face downwards.
- (2) Place the magnet on the surface plate and set the dial indicator to zero on the step marked "C" of the small gauge block; this is the width of a standard bearing. Transfer the indicator to the plain surface of the bearing inner race and, holding the race down against the balls, note the reading on the dial. A **negative** reading shows the additional thickness to be **added** to the collar at this side; a **positive** reading, the thickness to be **subtracted**.

*Right-hand side:*

Formula:  $B - D \div .1825$  in. (4.634 mm.).

The procedure is the same as that for the left-hand side.

**Units not marked with tolerances:** Some early models are fitted with differentials bearing no markings except the correct backlash for that particular pair of gears. The differential in such a case can be set as follows:—

- (1) Fit the differential to the carrier with a distance collar at each side.  
By trial and error select collars of thicknesses

# J

## REAR AXLE AND SUSPENSION

such that the differential with bearings and collars just fits into the carrier without slack and without pinching the bearings.

- (2) Remove the unit and add .002 in. to the thickness of the collar at each side to give the required pre-load.
- (3) Fit the unit to the carrier and bolt up.
- (4) Check and adjust the backlash as detailed below.

### Adjusting Backlash

- (1) Assemble the bearings to the differential cage and refit the differential to the gear carrier with the collars of calculated thickness.
- (2) Mount the dial indicator on the magnet bracket so that an accurate measurement of the backlash can be taken. The recommended backlash is etched on the crown wheel.
- (3) Vary the backlash by decreasing the thickness of the collar at one side and increasing the thickness of the collar at one side and increasing the thickness of the collar at the other side by the same amount, thus moving the crown wheel into or out of mesh as required. The total thickness of the two collars must not be changed.
- (4) A tolerance of  $-.002$  in. ( $-.05$  mm.) to  $-.001$  in. ( $-.025$  mm.) on the recommended backlash is allowable so long as this does not bring it below a minimum of  $.006$  in. ( $.152$  mm.) or above a maximum of  $.012$  in. ( $.306$  mm.).

## Section J.7

### REAR SPRINGS

#### Description

The road springs are of the semi-elliptical type. The rear ends pivot in shackles to allow for variation in the effective lengths of the springs as they are flexed on load or rebound. The front ends of the springs are mounted in rigid brackets on the chassis longitudinal members. Driving and braking forces are transmitted from the axles to the chassis by this end of the springs.

Two rubber buffers attached to the axle limit any excessive upward or bump movement of the axle.

The rear spring dampers are of the lever, hydraulic type and are mounted to brackets on the chassis longitudinal members. The levers are attached to brackets on the axle. A filler plug is located in the top plate of each rear damper.

#### Maintenance

- (1) Examine and tighten, if necessary the spring "U" bolts.
- (2) Examine the oil level in the rear spring dampers and top up if necessary.
- (3) Clean the springs and wipe them with an oily rag.

- (4) Examine the springs for fractures and the bushes for wear.

#### To Remove

- (1) Jack up the car on that side from which the spring is to be removed.
- (2) Pack up the chassis rear cross member with suitable supports, placing the supports as near to the spring rear anchorage as possible.
- (3) Place a screw jack under the centre of the spring to relieve the tension.
- (4) Remove the respective wheel.
- (5) Using a box spanner release the four self-locking nuts from the "U" bolts which secure the spring to the axle tube.
- (6) Detach the nut and spring washer on the inside of the upper rear shackle, and the locknut, spring washer and nut on the inside of the lower rear shackle.

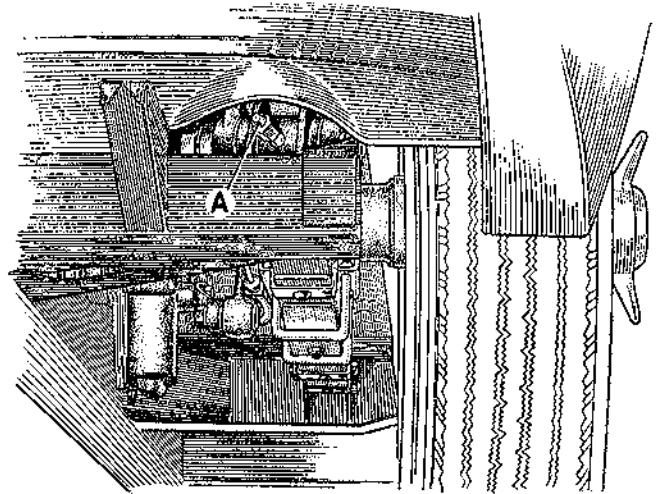

Fig. J.11. This illustration shows the position of the rear spring lubricator beneath the luggage compartment.

- (7) Remove the shackle inside connecting link and extract the top and bottom shackle pins, together with the outside link.
- (8) At the forward end of the spring detach the anchor pin by removing the nut and spring washer on the inside of the pin and drive the pin clear.
- (9) Remove the supporting jack from under the spring to withdraw the latter from the car.

#### To Dismantle

- (1) Grip the spring in a vice jaws against the top and bottom leaves, adjacent to the centre bolt.
- (2) Unscrew the clips.



- (3) Unscrew the nut from the centre pin and withdraw the pin.
- (4) Open the vice when the spring leaves, together with the zinc interleaving will separate.
- (5) Examine the zinc interleaves for signs of failure or cracks.

### To Reassemble

- (1) Replace the spring in a vice.
- (2) Utilising a rod of similar diameter to the damping bolt and having a tapered end, position the leaves so that the clamping bolt can be readily replaced without risk of damage to the thread.
- (3) Replace the clamping bolt and secure by its nut and spring washer.
- (4) Refit the leaf clips renewing their pins if necessary.

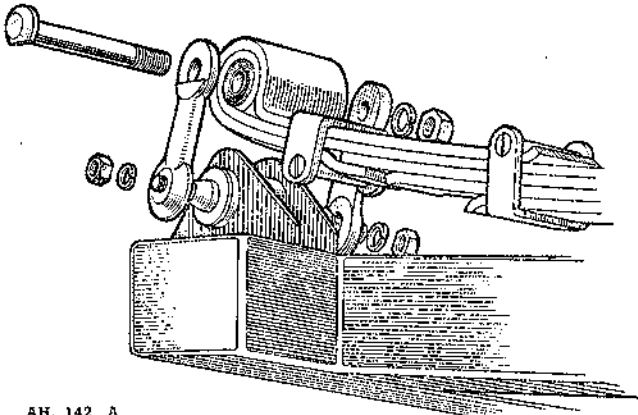

AH. 142. A.

Fig. J.12. Spring rear shackle assembly in exploded form.

## Section J.8

### SHOCK ABSORBERS

#### Description

The shock absorbers are Armstrong double-acting hydraulic, resistance being offered to the compression and to the recoil of the road springs.

Shock absorber maintenance is confined to the periodical examination of the anchorage to the chassis, the two fixing bolts being tightened as required, and topping-up with fluid.

No adjustment is required or provided for, and any attempt to dismantle the piston assembly will seriously affect the performance of the shock absorber.

### To Remove

- (1) Remove the nut and spring washer that secure the shock absorber lever to the link arm between lever and axle.
- (2) Withdraw the two fixing setpins from the shock absorber body and chassis bracket.
- (3) Remove the shock absorber, threading the lever over the link arm bolt.

### To Replace

The replacement of a rear shock absorber is a reversal of the removal procedure. However, when handling shock absorbers that have been removed from the chassis for any purpose, it is important to keep the assemblies upright as much as possible otherwise air may enter the working chamber and so cause erratic resistance.

### Connecting Link Bushes

The rubber bushes integral with both ends of the connecting link which joins the shock absorber to the rear axle cannot be renewed. When these bushes are worn the arm must be renewed complete.

## Section J.9

### ANTI-SWAY BAR

The anti-sway bar is a torsion bar anchored by a bracket welded to the axle casing and at the right-hand chassis member by a bracket welded to the frame.

# J

## REAR AXLE AND SUSPENSION

### Section J.10

#### FAULT DIAGNOSIS

Symptom	No.	Possible Fault
(a) Noisy Axle { (i) On drive (ii) On coast (iii) On drive and coast	1	Insufficient crown wheel/pinion backlash
	2	Excessive crown wheel/pinion backlash
	3	Insufficient lubricant
	4	Chipped, broken or scored teeth
	5	Damaged or worn bearings
(b) Broken Crown Wheel and Pinion Teeth	1	Excessive loads
	2	Clutch snatch
	3	Incorrect backlash adjustment
	4	Incorrect differential bearing adjustment (pre-load)
(c) Broken or Scored Differential Gear Teeth		In (a), check 3
		In (b), check 2
(d) Differential Shaft Breakage	1	Misaligned or bent differential shafts
	2	Badly worn differential wheel and pinion thrust washers
(e) Overheating		In (a), check 1 and 3
	1	Bearings adjusted too tightly
(f) Oil Leaks	1	Damaged gear carrier flange
	2	Damaged or broken joint washers
	3	Worn or damaged oil seals

## REAR AXLE AND SUSPENSION

**J**

Symptom	No.	Possible Cause
<b>(g) Hard riding</b>	1	“U” bolts or front spring fixing bolts loose, causing spring or axle to move, or the spring centre bolt to break.
	2	Vehicle overloaded.
	3	Load distribution uneven.
	4	One or more spring leaves broken
<b>(h) Overflexibility</b>	1	Loss of damper fluid.
	2	Dampers not operating
	3	Spring clips broken
<b>(j) Excessive noise</b>	1	Worn or damaged shackles, pins or bushes
	2	Loose damper mountings
	3	Worn damper bushes
	4	Axle and springs misaligned, because of loose “U” bolt or front spring fixing bolt nuts or broken centre bolt.

### MODIFICATION REFERENCES

<i>Service Reference Number</i>	<i>Date</i>	<i>Subject</i>	<i>Details of Changes</i>



# **SECTION K**

## **STEERING**

Section No. K.1	Description
Section No. K.2	Maintenance
Section No. K.3	Adjustments in the vehicle
Section No. K.4	Steering gear assembly
Section No. K.5	Steering idler
Section No. K.6	Side rods
Section No. K.7	Cross tube
Section No. K.8	Fault diagnosis

---



## Section K.1

### DESCRIPTION

The steering gear is a self-contained unit of extreme simplicity. The steering tube revolves a cam, which, in turn, engages with a taper peg fitted to a rocker shaft. This assembly is enclosed in an oil tight casing which carries two ball bearings at either end of the cam. These bearings are designed to carry radial and thrust loads.

When the steering wheel is turned the tube revolves the cam, which, in turn, causes the taper peg to move over a predetermined arc, thus giving the rocker shaft its desired motion. Attached to the rocker shaft is a steering side and cross tube lever, which links up with the steering linkage.

The steering is of the "three cross tube" type, having a centre cross tube connecting the steering side and cross tube lever to the arm on the idler shaft. Two shorter side tubes, one on either side, connect the steering arms to the steering gear and idler levers respectively.

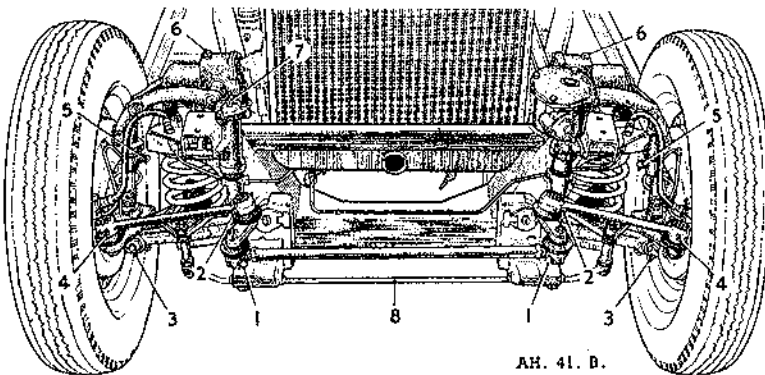

Fig. K.1. Showing the front suspension, steering layout and lubrication points.

1. Cross tube connections.
2. Side rod inner connections.
3. Lower link.
4. Side rod outer connections.
5. Swivel pin.
6. Shock absorber.
7. Steering idler.
8. Anti-roll bar (no lubrication required).

## Section K.2

### MAINTENANCE

Lubrication of the oil nipples on the steering connections and swivel bearings is most important to maintain accurate steering.

Approximately every 1,000 miles (1500 km.), use the oil gun with recommended oil to charge the following points with lubricant :—

- (a) Steering rods and cross tube—6 nipples.
- (b) Lower wishbone arm outer bearing—2 nipples.
- (c) Swivel pin bushes—4 nipples.
- (d) Steering idler—1 oil filler plug.

The steering box should be topped up with recommended oil to the top of the filler plug opening approximately every 1,000 miles (1500 km.).

## Section K.3

### ADJUSTMENTS IN THE VEHICLE

The following adjustments maintain the performance of the steering at its maximum and consist of aligning the front wheels and taking up backlash in the steering gear. Proceed as detailed below.

- (1) Front wheel alignment is governed by four factors—camber, castor, swivel pin inclination and wheel toe-in. The correct camber and swivel pin angles are built into the front suspension and will change only if the suspension is distorted by accidental damage. It is most important that the front wheels should toe-in  $\frac{1}{16}$  in. (1.58mm) to  $\frac{1}{8}$  in. (3 mm.), and this is governed by the angle of the track-rod arms and the length of the track-rod. An adjustment is provided so that the track-rod may be lengthened or shortened to maintain the correct alignment. The track-rod should not be adjusted to correct a bent track-rod arm.

The track is best adjusted by means of a Dunlop Optical Alignment Gauge, particulars of which can be obtained from the Dunlop Rubber Co. Ltd., Fort Dunlop, Erdington, Birmingham, England.

The cross tube is threaded right-hand at one end and left-hand at the other, so that the track adjustment can be made by simply rotating the tube in the required direction after releasing the locknuts. Always re-tighten the locknuts at each end of the cross tube after an adjustment has been made.

The side-rods are non-adjustable.

When adjusting the track the following precautions should be observed :—

- (a) The car should have come to rest from a forward movement. This ensures as far as possible that the wheels are in their natural running position.
- (b) It is preferable for alignment to be checked with car laden.

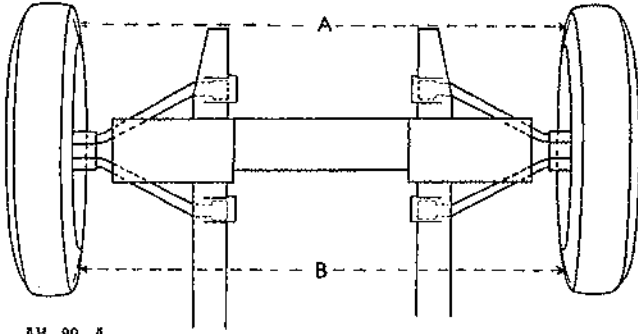

AH. 90. A.

Fig. K.2. The toe-in must be adjusted so that A is  $\frac{1}{16}$  in. to  $\frac{1}{8}$  in less than B.

- (c) With conventional base-bar tyre alignment gauges measurements in front of and behind the wheel centres should be taken at the same points on the tyres or rim flanges. This is achieved by marking the tyres where the first reading is taken and moving the car forwards approximately half a road wheel revolution before taking the second reading at the same points. With the Dunlop Optical Gauge two or three readings should be taken with the car moved forwards to different positions—180° road wheel turn for two readings and 120° for three readings. An average figure should then be calculated.

Wheels and tyres vary laterally within their manufacturing tolerances, or as the result of service, and alignment figures obtained without moving the car are unreliable.

- (2) Steering cam bearing adjustment should be carried out to eliminate all perceptible end play. To adjust the cam bearings, proceed as follows :—
- From underneath the vehicle disconnect the side rod from the steering lever to free the gear of all loads.
  - Disconnect the flashing indicator switch and horn push cables at the snap connectors behind the radiator grille and, from inside the vehicle, gently draw out the indicator switch and horn push, see Section N.31, until the cables have been drawn into the stator tube, being thus protected from oil.
  - Place an oil tray under the steering box.
  - Remove the nut and olive from the end cover and remove the end cover by unscrewing the four retaining bolts.
  - Add or remove shims as necessary to obtain the correct adjustment. The steering wheel should turn freely when held lightly at the rim with the thumb and forefinger, but should have no end play.

- (3) Rocker-shaft adjustment should be carried out after adjusting the cam bearings (described above).

- With the side rod still disconnected from the steering lever, slacken the adjusting screw locknut and screw in the adjusting screw.
- Check for backlash by exerting a light pressure on the lower end of the steering lever alternatively in both directions, while an assistant turns the steering wheel slowly from lock to lock. It will be noticed that the amount of slackness is not constant, there being less slackness in the centre than in the full lock position. If slackness appears at all positions of the drop arm, the adjusting screw should be screwed in farther. After further adjustment, test again in the same manner. The correct adjustment is such that a "tight spot" will barely be apparent as the steering wheel is removed past the centre position, with no backlash at the steering droparm. At this position tighten the adjusting screw locknut.
- Refill the steering box with the correct grade of oil.
- Reconnect the side rod.

### Section K.4

#### STEERING GEAR ASSEMBLY

##### To Remove

- Remove the horn quadrant as described in Section N.31.
- Prize off the circlip, exposed to view, and then release the locking ring behind the steering wheel hub.

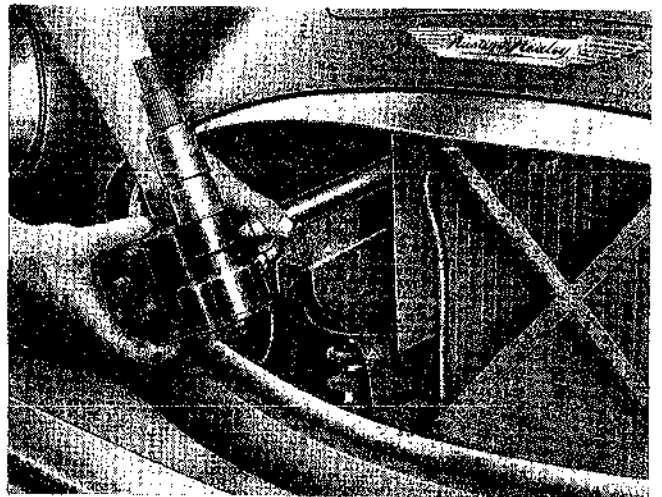

Fig. K.3. Showing the steering column being manoeuvred out through the radiator grille aperture.



## STEERING

# K

- (3) Pull the steering wheel clear of the column, followed by the telescopic spring and locating collar.
- (4) From behind the fascia release the two-piece clamping bracket supporting the top end of the column.
- (5) Remove the radiator as described in Section C.
- (6) Remove the radiator grille as described in Section P.
- (7) There are two sealing plates, one on each side of the scuttle, through which the steering column passes, release each plate by undoing the four metal thread screws.
- (8) Jack up the front of the car and remove the front wheels.

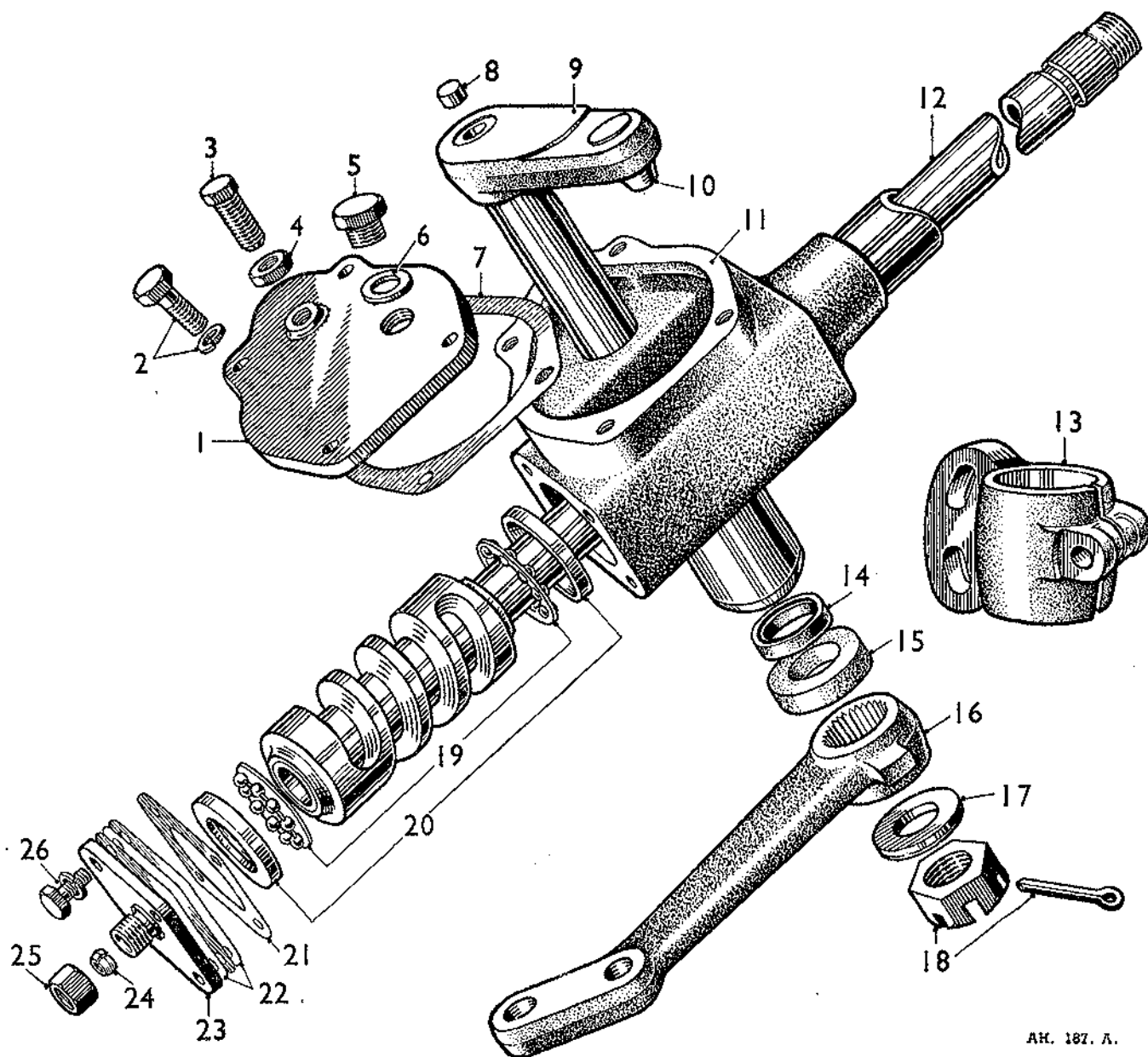

AH. 187. A.

Fig. K.4. Components of the steering box.

- |                          |                           |                                 |
|--------------------------|---------------------------|---------------------------------|
| 1. Top cover.            | 10. Follower peg.         | 18. Castellated nut and washer. |
| 2. Setpin and washer.    | 11. Steering box.         | 19. Inner races.                |
| 3. Adjusting screw.      | 12. Inner column.         | 20. Outer races.                |
| 4. Locknut.              | 13. Steering box bracket. | 21. Joint washer.               |
| 5. Filler plug.          | 14. Oil seal.             | 22. Adjusting shims.            |
| 6. Washer.               | 15. Dust excluder.        | 23. End cover.                  |
| 7. Joint washer.         | 16. Steering lever.       | 24. Olive.                      |
| 8. Adjusting screw stop. | 17. Washer.               | 25. Stator tube nut.            |
| 9. Follower peg screw.   |                           | 26. Setpin and washer.          |

# K

## STEERING

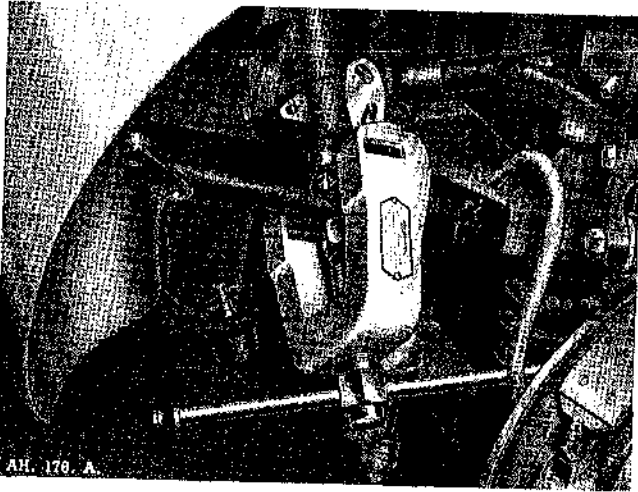

Fig. K.5. Using Service Tool GT.75 to remove steering lever.

- (9) Disconnect the cross tube and side rod from the steering lever as described in Section K.6.
- (10) Unscrew the three nuts and bolts securing the steering box mounting bracket to the chassis.
- (11) Manoeuvre the steering column together with the steering box downwards and forwards out of the radiator grille opening, see Fig. K.3.

### To Dismantle

- (1) Extract the split pin and unscrew the castellated nut at the base of the steering lever. Pull the steering lever off the splines by using a suitable extractor.
- (2) Unscrew the four setscrews securing the steering box top cover plate, and remove the plate.
- (3) Turn the steering gear over and suitably support the top face when the rocker shaft can be lightly tapped out using a soft metal drift.

**Note.**—The follower peg, situated in the rocker, is a pressed fit. The peg is peined over at the top to ensure complete security and should only be removed if showing an appreciable amount of wear.

- (4) Release the nut and olive at the steering box end of the column allowing the oil to drain into a suitable receptacle and withdraw the long stator tube.
- (5) Remove the four setpins holding the end cover plate in position and release the end cover.
- (6) Up end the complete unit so that the steering box is uppermost.
- (7) Displace the worm and its two ball bearings by bumping the end of the inner shaft on a piece of wood placed on the floor.
- (8) Withdraw the complete inner column from the casing via the open end of the steering box.

- (9) Extract the ball race at the top of the outer casing of the column by pulling it upwards by hand, or if it is tight, ease it from the column with a screwdriver behind the protruding lip. Replacing the ball race merely entails pushing it into place.
- (10) Clean all components in paraffin and blow them dry with compressed air.
- (11) Examine the rocker shaft, rocker shaft bush and splines for wear.
- (12) Examine the steering column shaft cam for excessive wear in the grooves.
- (13) Carefully examine the steering lever for cracks and accidental damage.

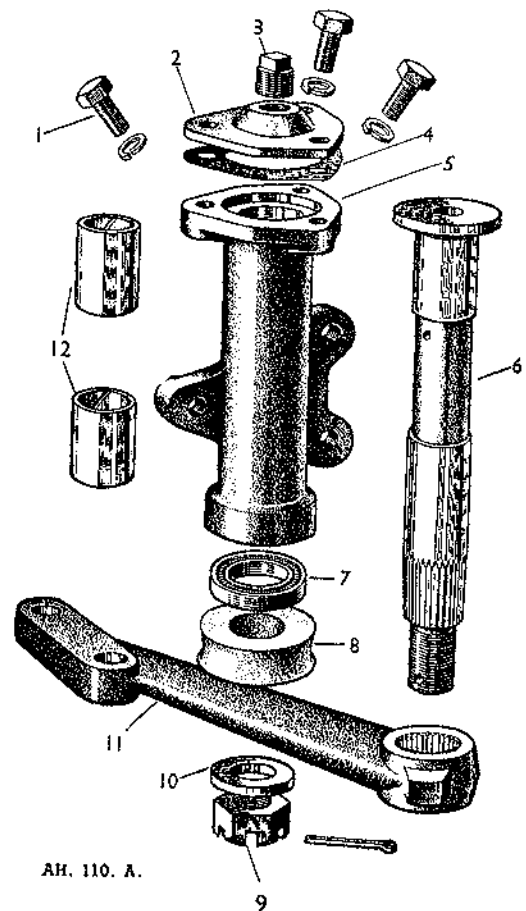

AH. 110. A.

Fig. K.6. Steering idler exploded.

- |                  |                     |
|------------------|---------------------|
| 1. Cap setpin.   | 7. Oil seal.        |
| 2. Idler cap.    | 8. Dust excluder.   |
| 3. Oil plug.     | 9. Castellated nut. |
| 4. Joint washer. | 10. Plain washer.   |
| 5. Idler body.   | 11. Steering lever. |
| 6. Idler shaft.  | 12. Bush bearings.  |

### To Reassemble

Reassembly is a reversal of the removal procedure giving particular attention to adjustments as described in Section K.3. Before refitting the top cover plate, screw back the adjuster.

### To Replace

The replacement of the steering gear is a reversal of the procedure "To Remove", but observe the following precautions :—

- (1) Carefully align the steering column so that no bending stress is imposed upon it before tightening the support brackets.
- (2) Make sure that the steering wheel is in the centre of travel and the front wheels are in the straight ahead position when installing the side rod.

## Section K.5

### STEERING IDLER

#### To Remove

- (1) Disconnect the side and cross tubes from their connections at the idler lever.

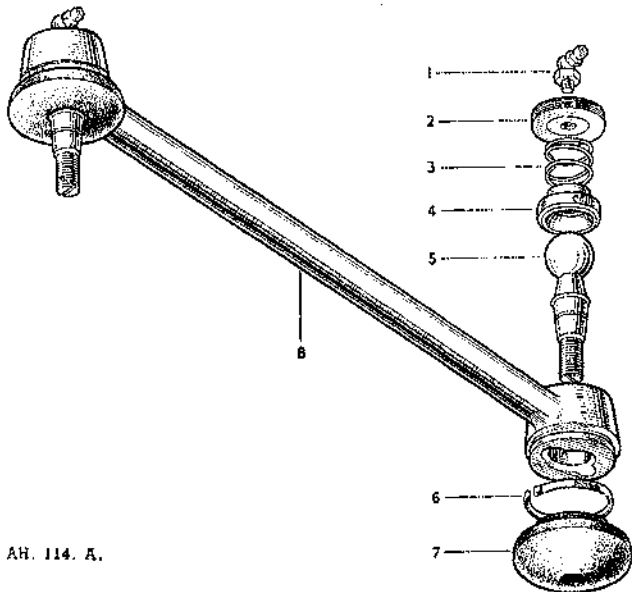

AH. 114. A.

Fig. K.7.

An exploded view of a non-adjustable type ball and socket connection.  
 1. Oil nipple. 2. Screwed fixing plate. 3. Spring. 4. Socket. 5. Ball.  
 6. Spring clip. 7. Rubber boot. 8. Side rod.

- (2) Unscrew the three setscrews which secure the idler to its mounting bracket.
- (3) Lift the idler and its lever clear of the body.

#### To Dismantle

- (1) Unscrew the three setscrews securing the idler cap to the idler body.
- (2) Remove the split pin, castellated nut, idler lever and dust excluder from the base of the idler body.
- (3) Pull the idler shaft upwards through the idler body taking care not to damage the oil seal.
- (4) Tap out the oil seal.
- (5) Check the two bush bearings for wear and renew if necessary.

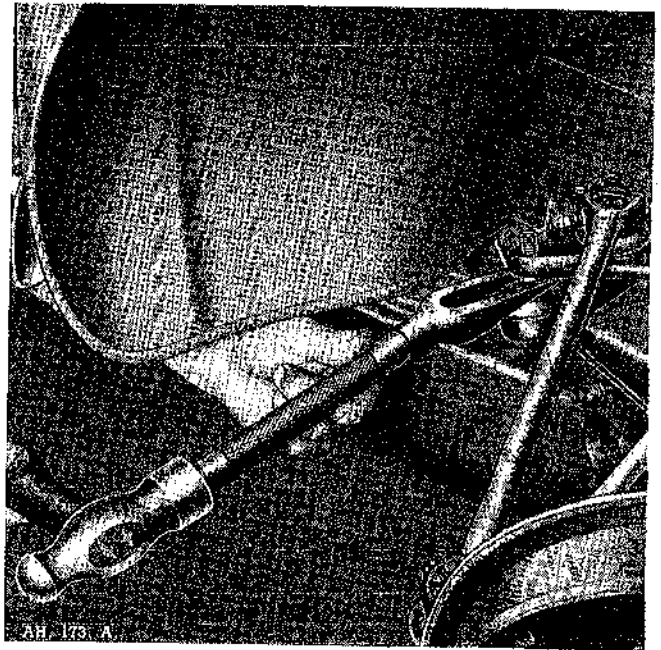

Fig. K.8. Using Service Tool 18G 125 to separate the ball and socket connection from the steering lever.

#### To Assemble and Replace

The assembling and replacement is a reversal of the procedure to dismantle and remove. Ensure that an oil tight seal is maintained at the base of the idler body.

## Section K.6

### SIDE RODS

#### To Remove

- (1) Withdraw the split pins and remove the nuts from the ball pins at the steering lever end and the swivel arm end of the side rod.
- (2) Loosen the ball pins from the steering lever and swivel arm by using the forked wedge tool 18G 125, and remove the side arm.

#### To Dismantle

- (1) Remove the dust covers from the ball pins and sockets by releasing the clips and levering the covers off. Further dismantling of the socket assemblies is not permissible.
- (2) Check the ball pins for wear. They must be tight enough to prevent end play, yet loose enough to allow free movement. Renew as complete assemblies if necessary.
- (3) Renew the dust covers if damaged.
- (4) Examine the side rod for damage. Renew if it is bent or damaged.

# K

## STEERING

### Section K.7

#### CROSS TUBE

##### To Remove

The removal of the cross tube from the steering lever and the idler lever is similar to that of the side rods.

##### To Dismantle

- (1) Slacken the socket locknuts at each end of the cross tube and unscrew the socket assemblies

which are screwed left-hand and right-hand respectively.

- (2) Follow the procedure described in "To Dismantle" Section K.6.

**Note.**—The procedures to assemble and replace the side rods and cross tube is the reverse of the procedures for removing and dismantling them, with the precaution that after replacing the cross tube the "toe-in" should be checked as described in Section K.3.

### Section K.8

#### FAULT DIAGNOSIS

Symptom	No.	Possible Fault
(a) Wheel Wobble	1	Unbalanced wheels and tyres
	2	Slack steering connections
	3	Incorrect steering geometry
	4	Excessive play in steering gear
	5	Broken or weak front springs
	6	Loose idler mounting or worn idler shaft
	7	Worn hub bearings
	8	Loose or broken shackles
(b) Wander		Check 2, 3, 4 and 8 in (a)
	1	Broken spring clips
	2	Front suspension and rear axle mounting points out of alignment
	3	Uneven tyre pressures
	4	Uneven tyre wear
	5	Weak shock absorbers or springs

# STEERING

**K**

Symptom	No.	Possible Fault
<b>(c) Heavy Steering</b>		Check 3 in (a)
	1	Excessively low tyre pressures
	2	Insufficient lubricant in steering box
	3	Insufficient idler lubrication
	4	'Dry' steering connections
	5	Out of track
	6	Incorrectly adjusted steering gear
	7	Misaligned steering column
<b>(d) Tyre Squeal</b>		Check 3 in (a)  Check 1 in (c)

### MODIFICATION REFERENCES

<i>Service Reference Number</i>	<i>Date</i>	<i>Subject</i>	<i>Details of Changes</i>



## **SECTION L**

### **FRONT SUSPENSION AND FRONT HUBS**

Section No. L.1	Independent front suspension
Section No. L.2	Coil springs
Section No. L.3	Front suspension (to remove)
Section No. L.4	Examination for wear
Section No. L.5	Front suspension (to replace)
Section No. L.6	Castor and camber angles and swivel pin inclination
Section No. L.7	Front hubs (disc wheels)
Section No. L.8	Front hubs (wire wheels)
Section No. L.9	Fault diagnosis

---





## Section L.1

### INDEPENDENT FRONT SUSPENSION

#### Description

The independent front suspension is known as the "wishbone" type, since the top and bottom linkages roughly conform to the shape of a wishbone. Between these two wishbones is the coil spring, held under compression between the top spring plate and the lower spring plate which is secured to the lower wishbone by four bolts.

The top wishbone is formed by the lever arms of a double-acting hydraulic shock absorber which is anchored to the top spring plate bracket by four bolts. At the swivel end, the top wishbone is secured to the swivel pin trunnion by means of a fulcrum pin and tapered rubber bushes. The bottom wishbone is secured by a single lower link spindle and tapered rubber bushes to two mounting plates, bolted to the front suspension member, and by two screwed bushes and a screwed fulcrum pin to the lower end of the swivel pin.

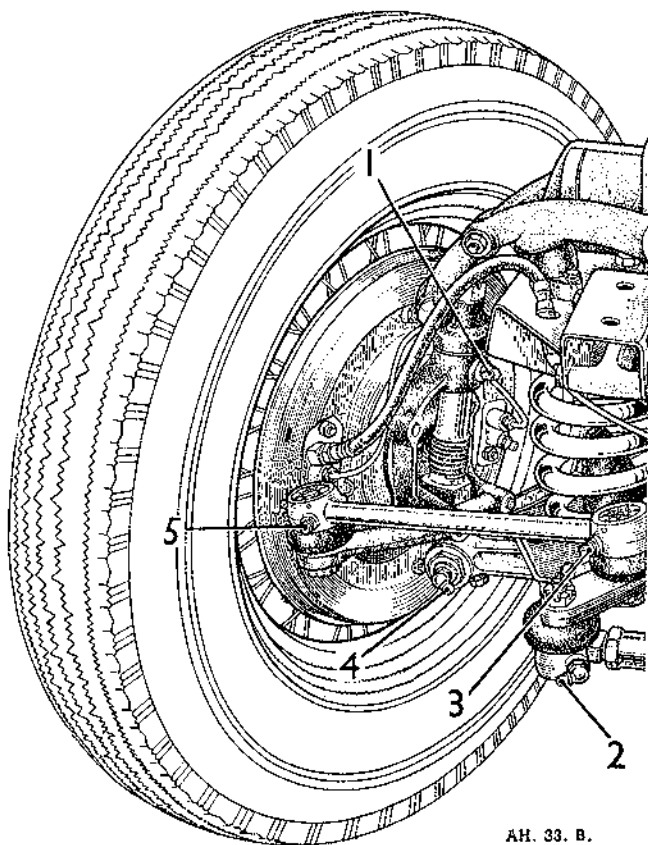

Fig. L.1. Front suspension lubrication.

- |                           |                                |
|---------------------------|--------------------------------|
| 1. Swivel pin.            | 2 and 5. Side rod connections. |
| 3. Cross tube connection. | 4. Lower link bushes.          |

#### Checking for Wear

The following tests should be made to check for wear in various components of the front suspension unit.

- (1) Wear of the swivel pin, or bushes, or both, may be checked by jacking up the front of the car and endeavouring to rock the wheel by grasping opposite points of the tyre in a vertical position. If any sideways movement can be detected between the swivel axle assembly, the swivel pin or the swivel pin bushes are worn and must be stripped for examination.
- (2) Up and down, or sideways movement of the shock absorber cross shaft, relative to the shock absorber casting, denotes wear of the shock absorber shaft bearings which can only be remedied by refitting a new shock absorber. These bearings are best checked when the suspension is dismantled and when with some freedom of movement, it is possible to move the top wishbone arms, which are attached at their inner ends of the shock absorber cross shaft.
- (3) The rubber bearing bushes used for the upper wishbone arm outer bearings and for the lower wishbone arm inner bearings may in time deteriorate and need renewing. Excessive sideways movement in either of these bearings would denote softening of the rubber bushes.
- (4) The screwed bushes or the screwed trunnion fulcrum pin of the lower wishbone arm outer bearing assembly may develop excess free play due to wear of either of these parts. This assembly can best be checked when the suspension has been dismantled.

## Section L.2

### COIL SPRINGS

#### To Remove

- (1) Place a jack under the chassis front cross-member and raise the car until the front wheels are clear of the ground.
- (2) Remove the appropriate wheel by unscrewing the five securing nuts, or the "knock-on" hub cap if wire wheels are fitted.
- (3) Release the compression of the coil spring using Service Tool 18G 37. If this tool is not available use two  $\frac{3}{8}$  in. B.S.F. slave bolts of high-tensile steel, 4 in. long and threaded their entire length.
- (4) The bottom spring plate is secured to the suspension lower links by four self-locking nuts. Unscrew the nuts from two diagonally opposite bolts, remove the bolts and insert the two slave bolts in the vacated holes.

# L FRONT SUSPENSION AND FRONT HUBS

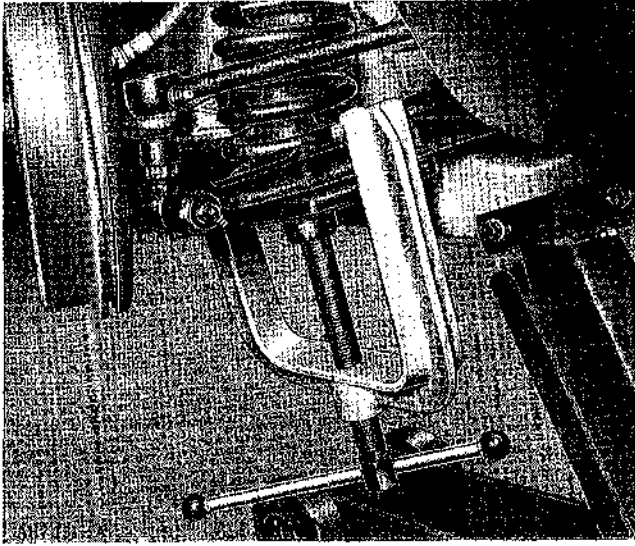

Fig. L.2. Illustrating the coil spring compressor (Service Tool 18G.37) in position.

- (5) Screw two nuts down securely onto the slave bolts and remove the remaining two short nuts and bolts.
- (6) Unscrew the nuts from the slave bolts, each, a little at a time.
- (7) When the spring is fully extended, release the bolts and remove the spring plate and coil spring.

## To Replace

The replacement of the coil springs is a reversal of the procedure to remove, making sure that all securing nuts and bolts are fully tightened.

## Section L.3

### FRONT SUSPENSION

#### To Remove

- (1) Remove the coil spring as described in Section L.2.
- (2) Disconnect the steering side tube from the steering arm by withdrawing the split pin and unscrewing the nut, see Section K.
- (3) Disconnect the flexible brake pipe from the brake backplate, tying to some higher point to prevent unnecessary loss of fluid.
- (4) With the suspension unit supported, remove the fulcrum pins securing the lower wishbone arms to their brackets on the frame, taking care to retrieve the two rubber bushes and special washers from each bearing.
- (5) Unscrew the four setpins securing the shock absorber to the top spring bracket.
- (6) Lift the suspension unit clear of the car.

#### To Dismantle

- (1) Unscrew the nut from the clamping bolt connecting the top wishbone arms together.
- (2) Remove the split pin and nut from the upper trunion fulcrum pin on the outer end of the top wishbone arms.
- (3) The forward arm (left-hand suspension unit) of the top wishbone is secured to the shock absorber spindle by a clamping bolt. Slacken the clamping bolt and partially withdraw the arm. The trunion fulcrum pin can now be withdrawn and the shock absorber removed complete with the top wishbone arms.
- (4) Withdraw the rubber bearing from each end of the upper trunion. The bearings fit into a groove in the swivel pin and must be taken out before the swivel pin is removed.
- (5) Take out the split pin and unscrew the nut from the top of the swivel pin.
- (6) Remove the upper trunion and the three thrust washers and lift off the swivel axle and hub assembly.
- (7) Detach the cork washer from the lower end of the swivel pin.
- (8) Slacken the nut on each of the half moon cotters located in the ends of the lower wishbone arms, screw out the two threaded bushes and detach the arms.
- (9) Unscrew the nut from the cotter, located in the centre of the lower trunion, and tap out the cotter.
- (10) Withdraw the fulcrum pin and remove the cork washer from each end of the trunion.

## Section L.4

### EXAMINATION FOR WEAR

#### Swivel Pin

- (1) Carefully examine the swivel pin for wear by checking for ovality with a micrometer.
- (2) If the pin does not show any appreciable wear renewal of the swivel bushes may effect a satisfactory cure. The bushes can easily be driven out or replaced with a suitable drift.

**Note.**—When refitting the top bush the oiling hole must locate with the oil hole in the swivel housing. The second bush must be flush with the recessed housing and protrude about  $\frac{1}{8}$  in. above the lower housing upper face.

- (3) Ream the bushes from the bottom as necessary using Service Tools 18G 64 and 18G 65.
- (4) Check the efficiency of the dust covers and renew if necessary.

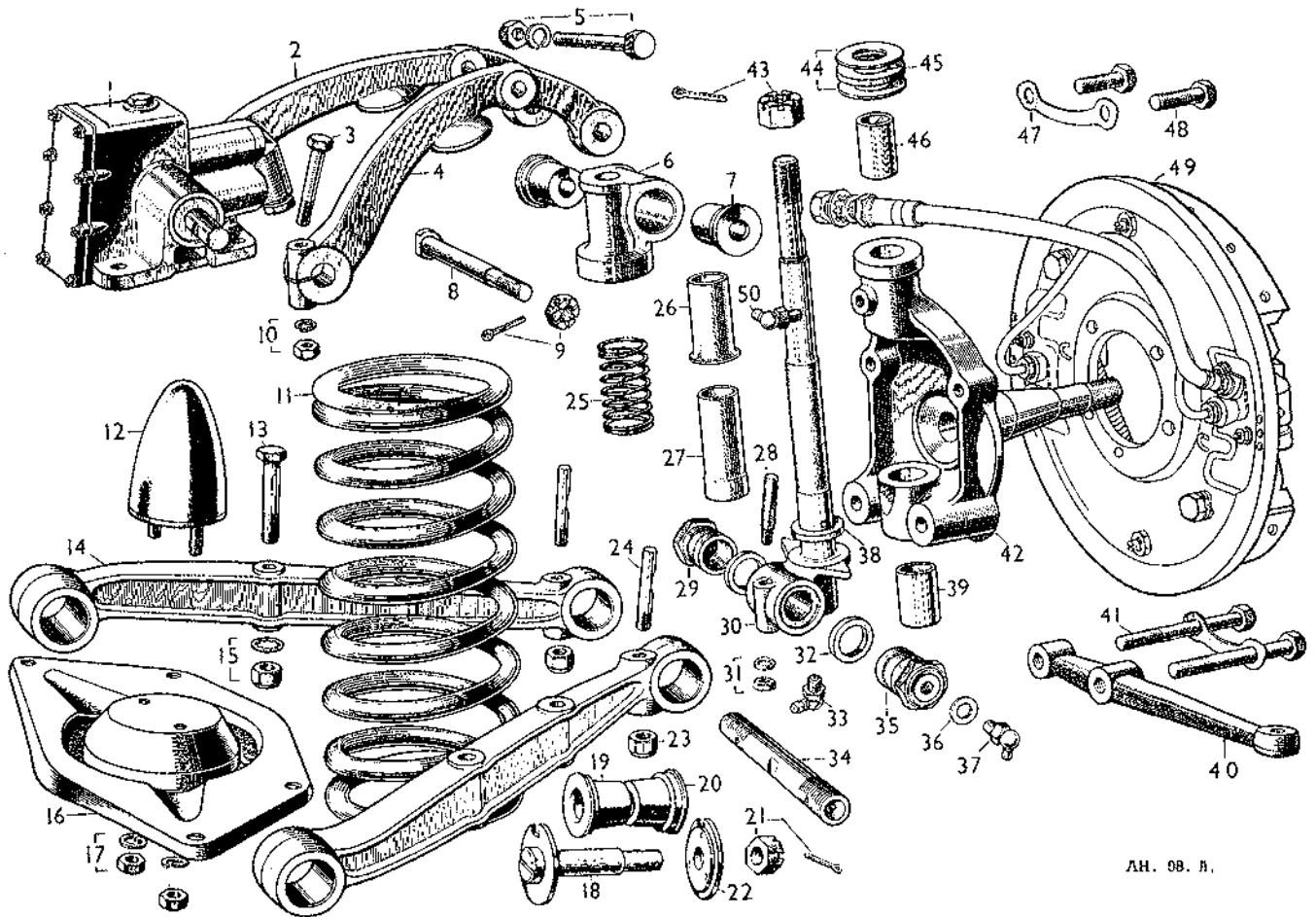

Fig. L.3. Components of the independent front suspension.

- |  |  |                                   |
|--|--|-----------------------------------|
| 1. Shock absorber.                       | 18. Fulcrum pin for inner lower bearing. | 35. Front screw bush.             |
| 2. Rear top wishbone arm.                | 19. An inner lower rubber bearing.       | 36. Flat washer.                  |
| 3. Clamping bolt for front wishbone arm. | 20. An outer lower rubber bearing.       | 37. Oil nipple.                   |
| 4. Front top wishbone arm.               | 21. Fulcrum pin nut and split pin.       | 38. Cork ring.                    |
| 5. Joining bolt for top wishbone arms.   | 22. Fulcrum pin special washer.          | 39. Swivel axle lower bush.       |
| 6. Upper trunnion link.                  | 23. Nut for bush cotter.                 | 40. Steering arm.                 |
| 7. Trunnion rubber bearing.              | 24. Bush cotter.                         | 41. Steering arm setpin.          |
| 8. Upper trunnion fulcrum pin.           | 25. Swivel pin dust cover spring.        | 42. Swivel axle.                  |
| 9. Fulcrum locking nut and split pin.    | 26. Upper dust cover.                    | 43. Swivel pin nut and split pin. |
| 10. Nut and washer for clamping bolt.    | 27. Lower dust cover.                    | 44. Staybrite washers.            |
| 11. Coil spring.                         | 28. Cotter for fulcrum pin.              | 45. Oilite washer.                |
| 12. Rebound rubber bumper.               | 29. Rear screwed bush.                   | 46. Swivel axle upper bush.       |
| 13. Spring plate bolt.                   | 30. Swivel pin and lower trunnion.       | 47. Back plate setpin lockwasher. |
| 14. Rear lower wishbone arm.             | 31. Nut and washer.                      | 48. Back plate setpin.            |
| 15. Simmonds nut and lockwasher.         | 32. Cork ring.                           | 49. Back plate assembly.          |
| 16. Spring plate.                        | 33. Trunnion oil nipple.                 | 50. Swivel pin oil nipple.        |
| 17. Rebound bumper nut and washer.       | 34. Screwed fulcrum pin.                 |                                   |

### Wishbone Arm Screwed Bush Bearing

- (1) Test to see if the screwed bushes can be moved backwards or forwards on the fulcrum pin thread.
- (2) If such movement is detected replace the bushes and if movement is still detected replace the fulcrum pin.

### Shock Absorbers

- (1) If any up and down or sideways movement of the cross shaft is detected the shock absorbers must be completely renewed.
- (2) Carefully examine the shock absorbers for any leaks and test for effective damping. Secure the

# L FRONT SUSPENSION AND FRONT HUBS

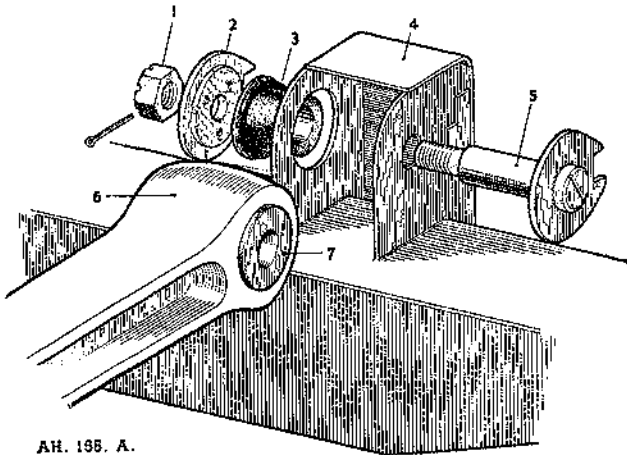

AH. 198. A.

Fig. L.4. Lower wishbone inner bearing assembly.

- |                     |                      |                  |
|---------------------|----------------------|------------------|
| 1. Castellated nut. | 3. Bush.             | 6. Wishbone arm. |
| 2. Special washer.  | 4. Mounting bracket. | 7. Bush.         |
|                     | 5. Fulcrum pin.      |                  |

shock absorber mounting plate in a vice and move the wishbone arms up and down through a complete stroke. A moderate resistance should be felt throughout the whole stroke.

If resistance is erratic it may mean that the fluid level is too low and that there are air-locks in the shock absorber. To rectify this remove the shock absorber filler plug and maintain the fluid at the correct level whilst the arms are moved steadily up and down through full strokes. If this treatment does not effect a cure the shock absorber must be renewed as a complete unit.

## Section L.5

### FRONT SUSPENSION

#### To Reassemble

- (1) Fit the screwed fulcrum pin into the lower trunnion at the bottom end of the swivel pin, ensuring that it is centralised and secured by means of its cotter pin.
- (2) Fit a cork ring into the recess provided at each end of the lower trunnion and place the lower wishbone arms in their respective positions. Ensure that the half-moon cotters are correctly positioned to receive the steel bushes which should be greased and partially screwed home.
- (3) Service Tool 18G 56 should be used to ensure that the alignment of the lower wishbone arm is correct. If this Service Tool is not available bolt the lower spring plate securely in position.
- (4) Screw the threaded bushes home evenly, then slacken them back one flat. Finally secure the bushes by tightening the nuts on each of the half-moon cotters. Do not overtighten the cotter nuts

as this may cause distortion of the bushes. If the assembly has been correctly carried out it will be possible to insert a .002 in. feeler gauge between the inner shoulder of the bush and the outer face of the wishbone arm on each side. The lower trunnion assembly should now operate freely in the screwed bushes.

- (5) Place the cork washer on the swivel pin with its chamfered face downwards and smear the swivel pin with a little clean engine oil.
- (6) Position the swivel axle and hub assembly on the swivel pin.
- (7) Refit the thrust washers.

**Note.**—The three thrust washers are made up of an “Oilite” washer interposed between two “Staybrite” washers. The “Staybrite” washers are supplied in varying thicknesses to permit adjustment, as it is necessary to provide easy operation of the swivel axle with the minimum amount of lift; the maximum permissible lift being .002 in.

- (8) Fit the upper trunnion and swivel nut, and check the clearance, correcting it if necessary by means of the “Staybrite” washers. Then slacken the swivel pin nut to permit further assembly.
- (9) Moisten the upper trunnion rubber bearings with water and place them in position.
- (10) Place the trunnion, with its bearings, in position between the two upper wishbone arms.
- (11) Refit the fulcrum pin, re-position and tighten the slackened upper wishbone arm to the shock absorber arms.

**Note.**—The swivel pin and upper trunnion fulcrum pin nuts must not be tightened at this stage.

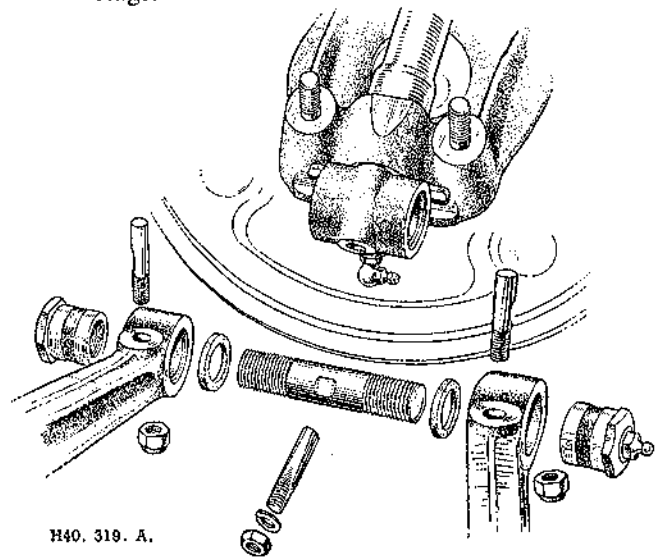

H40. 319. A.

Fig. L.5. This exploded view shows the screwed bush housing assembly at the lower end of the wishbone arms.

## To Replace

- (1) Fit one rubber bearing to each of the suspension lower links, on the side which corresponds to the small hole in each of the frame brackets.
- (2) Raise the links to the frame brackets, insert the fulcrum pins and slide the second bearing and special washer over the protruding end of each pin. Fit the nut but do not screw it home. Position the shock absorber on its top bracket and partially tighten the four setscrews.
- (3) The assembly must next be set in the normal loaded position. This can be accomplished by placing a distance piece between the shock absorber wishbone arm and the upper spring plate at a point opposite the rubber buffer. The length of the distance piece must be 2 in.
- (4) Tighten the nuts on the fulcrum pins securing the lower wishbone arms to the frame brackets. Do not forget to lock them with the split pins.
- (5) Tighten the four setscrews securing the shock absorber to its bracket on the frame.
- (6) Tighten the upper trunnion fulcrum pin nut and secure with a split pin.
- (7) Tighten the swivel pin nut and lock with a split pin.
- (8) Service Tool 18G 65, or the lower spring plate, whichever used, should now be removed from the lower wishbone arms and the coil spring refitted as already described.
- (9) Connect the brake fluid pipe to the brake backplate, secure the steering side tube to the steering arm, refit the road wheel, lower the car to the ground and remove the distance piece used to retain the suspension in the normal loaded position.
- (10) Finally, bleed the brakes as described in Section M.

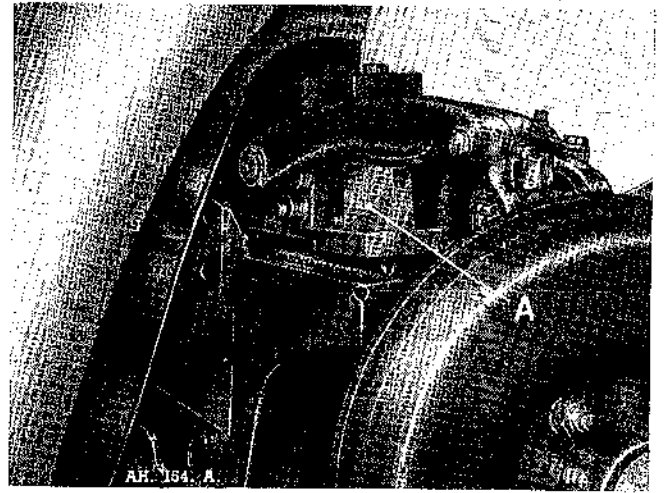

Fig. L.7. When building up the suspension, the arms must be correctly set by the distance piece A (2 in.) before the various bearings are tightened.

## Section L.6

### CASTOR AND CAMBER ANGLES AND SWIVEL PIN INCLINATION

#### Description

The castor and camber angles and the swivel pin inclination are three design settings of the front suspension assembly. They have a very important bearing on the steering and general riding of the car. Each of these settings is determined by the machining and assembly of the component parts during manufacture. They are not therefore adjustable.

However, should the car suffer damage to the suspension affecting these settings, the various angles must be verified to ensure whether replacements are necessary.

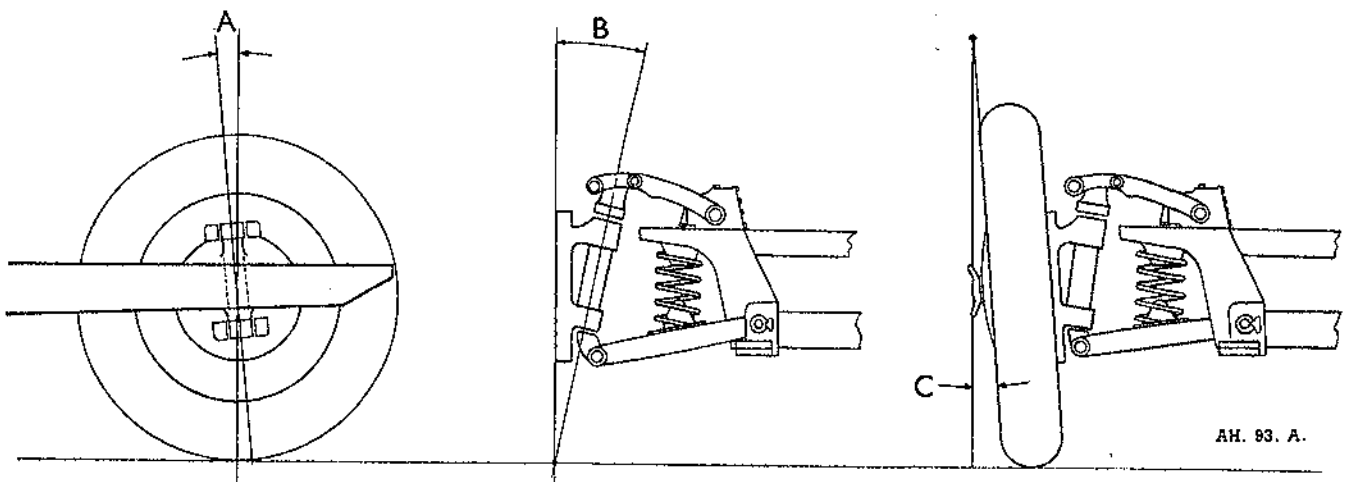

A. Castor angle  $1\frac{1}{2}^\circ$ .

B. Swivel pin inclination  $6\frac{1}{2}^\circ$ .

C. Camber angle  $1^\circ$

# L FRONT SUSPENSION AND FRONT HUBS

## Camber Angle

This is the outward tilt of the wheel and a rough check can be made by measuring the distance from the outside wall of the tyre, immediately below the hub, to a plumb line hanging from the outside wall of the tyre above the hub. The distance must be the same on both wheels. Before making this test, it is very important to ensure that the tyres are in a uniform condition and at the same pressure. Also that the car is unladen and on level ground.

Damage to the upper and lower wishbone arms may well affect the camber angle.

## Castor Angle

This is the tilt of the swivel pin when viewed from the side of the car. This also is only likely to be affected by damage to the upper and lower wishbone arms.

with both hands in the vertical position and rock the wheel. Movement between the wheel and the back plate denotes wear of the hub bearings. Should a very positive movement be apparent, the front hub bearings will need renewing.

## To Remove and Dismantle

- (1) Jack the car until the wheel is clear of the ground and then place blocks under the independent suspension spring plate. Lower the car on to the blocks.
- (2) Remove the wheel and the countersunk screw holding the brake drum. If the drum appears to bind on the brake shoes, the shoe adjusters should be slackened.
- (3) Lever off the hub cap, and then extract the split pin from the swivel axle locking nut. Using a box

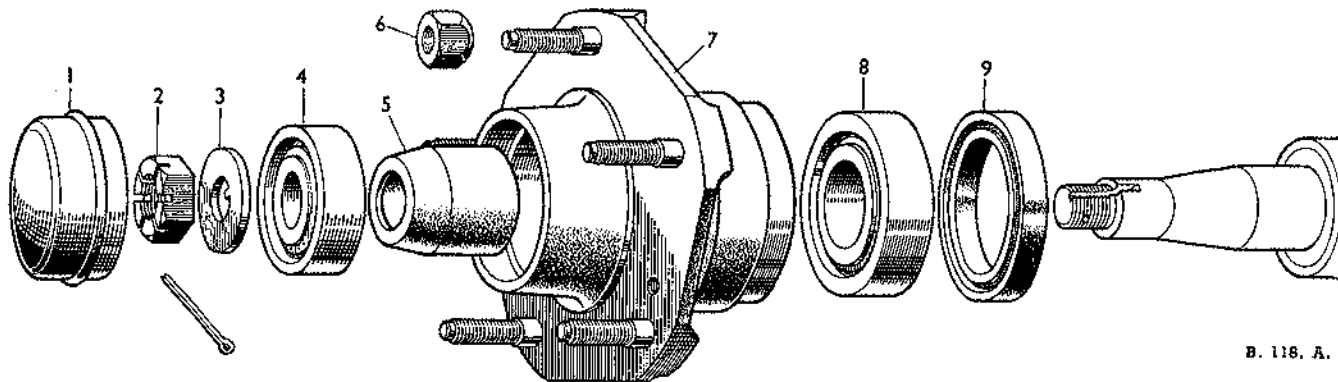

Fig. L.8. Front hub exploded (for disc wheels).

1. Hub cap.  
2. Castellated nut.  
3. Locating washer.

4. Outer bearing.  
5. Distance piece.  
6. Wheel nut.

7. Hub.  
8. Inner bearing.  
9. Oil seal.

## Swivel Pin Inclination

This is the tilt of the swivel pin when viewed from the front of the car and is again only likely to be affected by damage to the wishbone arms.

A useful tool which can be used for checking these settings is the Dunlop "wheel camber, castor and swivel gauge". With the car standing on level ground this gauge will give readings enabling the castor, camber and swivel pin angles to be quickly verified.

## Section L.7

### FRONT HUBS (Disc Wheels)

#### To Check for Wear

The inner and outer ball bearings of the front hub are non-adjustable, the amount of thrust being determined by a distance piece. To check for wear of these bearings, the car should be jacked until the wheel of the front hub is clear of the ground. Then grasp the tyre

spanner and tommy bar remove the axle nut and ease the flat washer, under the nut, clear of the axle thread.

- (4) The front hub can now be withdrawn by using an extractor, 18G 220, which fits over the wheel studs. The hub is withdrawn complete with the inner and outer bearings, the distance piece and the oil seal. Should the inner bearing race remain on the swivel axle it can be removed by carefully inserting a narrow rod into the two small holes, in turn, in each side of the swivel axle and tapping the race lightly.
- (5) With the hub removed, the outer bearing and the distance piece can be dismantled by inserting a drift through the inner bearing and gently tapping the outer bearing clear of the hub. The inner bearing and oil seal can then be removed by inserting the drift from the opposite side of the hub.

- (6) The removal of the brake backplate is described fully in the section on brakes.

### To Assemble and Replace

- (1) Insert the inner ball bearing race into the hub with the side of the race marked "thrust" facing the distance piece.
- (2) Pack the hub with **recommended** grease and then insert the distance piece so that the domed end faces the outer bearing.
- (3) Replace the outer bearing so that the "thrust" side faces the distance piece. Use a soft metal drift to replace both bearings, tapping them gently and alternately on diametrically opposite sides of the bearing to ensure they move evenly into their respective housings on the hub.

*Fig. L.9. Front hub exploded (for wire wheels).*

- |                   |                        |
|-------------------|------------------------|
| 1. Grease cup.    | 6. Bearing outer race. |
| 2. Axle nut.      | 7. Hub.                |
| 3. Split pin.     | 8. Bearing outer race. |
| 4. Washer.        | 9. Inner bearings.     |
| 5. Outer bearing. | 10. Oil seal.          |
|                   | 11. Swivel axle.       |

*Insert shows distance piece and shims.*

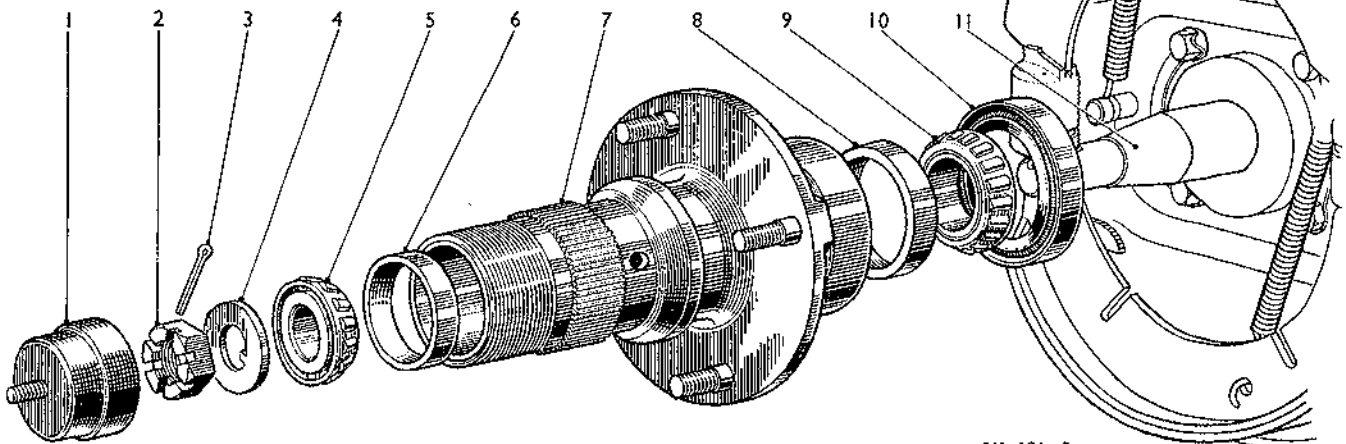

- (4) Replace the hub oil seal over the inner bearing so that the hollow side of the seal faces the bearing. Renew the seal if it is damaged in any way.
- (5) Replace the hub on the swivel axle, using a hollow drift which will bear evenly on both the inner and outer races of the outer hub bearing. Gently tap the hub into position until the inner race bears against the shoulder on the swivel axle.
- (6) Place the swivel axle flat washer into position and tighten the nut. The split pin should be inserted to lock the nut.
- (7) Tap the hub cap on to the hub after first packing the cap with grease.
- (8) Replace the brake drum and secure with the countersunk screw. It is important that the drum

is fully home before this screw is tightened and, if necessary, the drum should be pressed in position by tightening two wheel nuts.

- (9) Refit the wheel. The wheel nuts are best finally tightened when the car is off the jacking blocks, but re-adjust the brake shoes if necessary before the car is lowered to the ground.

## Section L.8

### FRONT HUBS

(Wire Wheels)

#### To Check for Wear

The inner and outer bearings of the front hub are of the taper roller type and are therefore adjustable. To check for wear of these bearings the car should be jacked

up until the wheel of the front hub to be checked, is clear of the ground. Movement between the wheel and the back plate denotes wear of the hub bearings. Should a very positive movement be apparent, the front hub bearings will need renewing.

#### To Remove and Dismantle

- (1) Jack up the car until the wheel is clear of the ground and then place blocks under the independent spring plate. Lower the car on to the blocks.
- (2) Remove the "knock-on" hub cap (direction of rotation marked on cap) and pull the wheel off the splines.
- (3) Release the nuts and washers holding the brake drum, then gently tap the brake drum clear of the

# L FRONT SUSPENSION AND FRONT HUBS

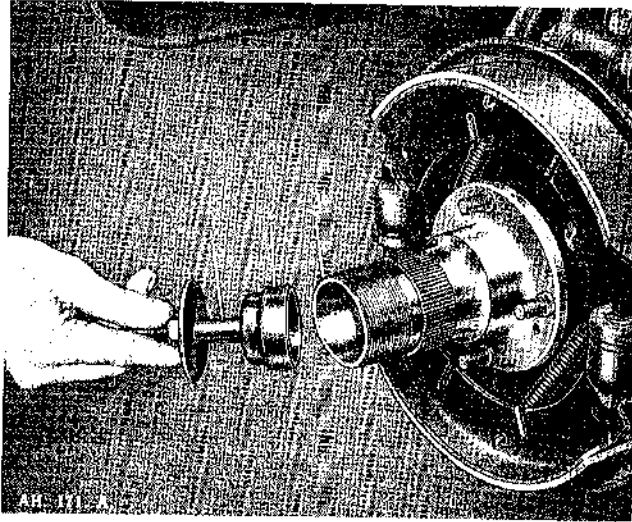

Fig. L.10. Showing the grease cap removed.  
1. Extractor. 2. Grease cup. 3. Hub.

front hub assembly. If the drum appears to bind on the brake shoes, the shoe adjusters should be slackened.

- (4) Use the extractor provided in the tool kit to extract the grease retaining cup from within the hub.
- (5) Straighten the end of the split pin and then prise it out through the hole provided in the hub.
- (6) Using a box spanner and tommy bar remove the hub securing nut and flat washer from the swivel axle.

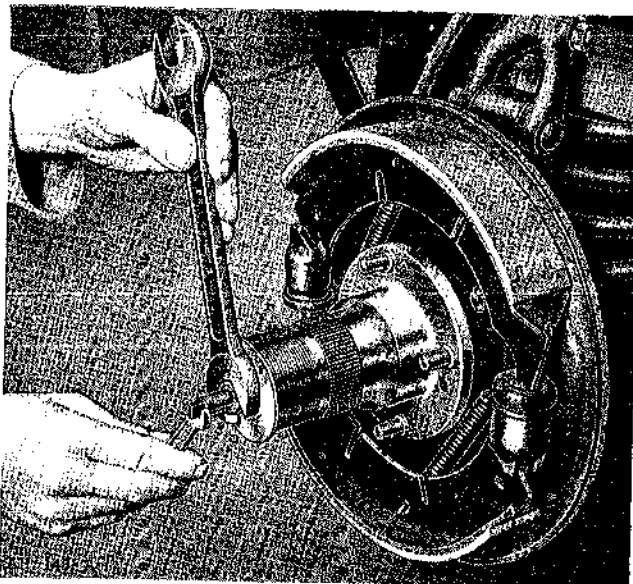

Fig. L.11. Using the special extractor to remove the grease retaining cup.

- (7) Withdraw the front hub using an extractor which is preferable to use an extractor which locates over the hub studs and is used. The hub is withdrawn completely, including the inner and outer bearings and oil seal.
- (8) With the hub removed, dismantle the outer bearing by inserting a drift through the inner bearing and gently tapping the outer bearing clear of the hub. The inner bearing can then be removed by inserting the drift through the opposite side of the hub.

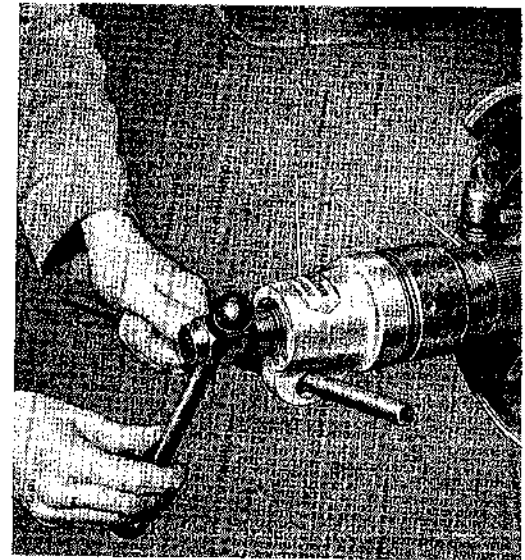

Fig. L.12. Extracting the front hub.  
1. Extractor. 2. Adaptor. 3. Hub.

## To Reassemble and Replace

- (1) Insert the inner taper roller bearings into the hub with the taper of the bearing facing in.
- (2) Pack the hub with recommended grease. Use a grease thicker than that recommended.
- (3) Insert the distance piece so that it fits snugly outwards.

**Note.**—When adjusting ascertain that the distance piece is a firm fit in the hub with the necessary shims. These shims are selected to eliminate shock, therefore do not use too much thickness so as to cause excessive preload of the bearings.

- (4) Replace the outer bearing so that the taper of the bearing faces the inside of the hub. Use a metal drift to replace both bearings by tapping gently on diametrically opposite sides of the hub so that they move evenly into their housings in the hub.



# FRONT SUSPENSION AND FRONT HUBS

L

- |  |  |
|--|--|
| <p>(5) Replace the hub oil seal over the inner bearing so that the hollow side of the seal faces the bearing. Renew this seal if it is damaged in any way.</p> <p>(6) Replace the hub on the swivel axle. This is best done by using a hollow drift which will bear evenly on both the inner and outer races of the outer hub bearing. Gently tap the hub into position against the shoulder of the swivel axle.</p> <p>(7) Place the flat washer on the swivel axle and screw the nut down finger tight with the aid of a box spanner.</p> <p>(8) Replace the brake drum and secure with the four spring washers and self-locking nuts.</p> | <p>(9) Install the wheel.</p> <p>(10) Tighten the axle nut with a spanner, and at the same time rotate the wheel back and forth until there is a noticeable drag. This ensures that the bearing cones are properly seated.</p> <p>(11) Unscrew the axle nut to line up with the nearest split pin hole. Insert the split pin through the hole provided in the hub casing and lock the axle nut.</p> <p>(12) Pack the retaining cap with grease and, using a drift, tap it gently but firmly up against the outer bearing.</p> <p>(13) Replace the hub cap.</p> |
|--|--|

## Section L.9

## FAULT DIAGNOSIS

Symptom	No.	Possible Fault
(a) Wheel Wobble	1 2 3 4 5 6 7 8	Unbalanced wheels and tyres Slack steering connections Incorrect steering geometry Excessive play in steering gear. Broken or weak front springs Loose idler mounting or worn idler shaft Worn hub bearings Loose or broken shackles
(b) Wander	1 2 3 4 5	Check 2, 3, 4 and 8 in (a) Broken spring clips Front suspension and rear axle mounting points out of alignment Uneven tyre pressures Uneven tyre wear Weak shock absorbers or springs
(c) Heavy Steering	1 2 3 4 5 6 7	Check 3 in (a) Excessively low tyre pressures Insufficient lubricant in steering box Insufficient idler lubrication "Dry" steering connections Out of track Incorrectly adjusted steering gear Misaligned steering column
(d) Tyre Squeal		Check 3 and 9 in (a) Check 1 in (c)



# **SECTION M**

## **BRAKES**

Section No. M.1	Description
Section No. M.2	Maintenance
Section No. M.3	Front brakes
Section No. M.4	Rear brakes
Section No. M.5	Brake pedal
Section No. M.6	Master cylinder
Section No. M.7	Fault diagnosis

---



## Section M.1

### DESCRIPTION

The brakes on all four wheels are hydraulically operated by foot pedal application, directly coupled to a master cylinder in which the hydraulic pressure of the brake operating fluid is originated. A supply tank cast integrally with the master cylinder provides a reservoir by which the fluid is replenished, and a pipe line consisting of tube, flexible hose and unions, interconnect the master cylinder and the wheel cylinders.

The pressure generated in the master cylinder by application with the foot pedal is transmitted with equal and undiminished force to all wheel cylinders simultaneously. This moves the pistons outwards, which in turn expand the brake shoes thus producing automatic equalisation, and efficiency in direct proportion to the effort applied at the pedal.

When the pedal is released the brake shoe springs return the shoes which then return the wheel cylinder pistons, and therefore the fluid back into the pipe lines and master cylinder.

An independent mechanical linkage actuated by a handbrake, mounted alongside the steering column cover, operates the rear wheels by mechanical expanders attached to the rear wheel cylinder bodies.

The front brakes are of the two leading shoe types with sliding shoes which ensure automatic centralisation of the brake shoe in operation.

The rear brakes are also fitted with sliding shoes, and incorporate the handbrake mechanism.

### Front Brakes

The front brakes are operated by two wheel cylinders situated diametrically opposite each other on the inside of the backplate and interconnected by a bridge pipe on the outside.

Each wheel cylinder consists of a light alloy body containing a spring seal support, seal, steel piston and edges of both shoes making initial contact with the drum. The shoes are allowed to slide and centralise during the actual braking operation which distributes the braking force equally over the lining area ensuring high efficiency and even lining wear.

Adjustment for lining wear is by means of two knurled snail cam adjusters, each operating against a peg at the actuating end of each shoe. Both adjusters turn clockwise to expand the shoes.

The brake shoes rest on supports formed in the backplate and are held in position by two return springs which pass from a hole in the abutment end of each web to a peg fixed to the backplate.

The bleed screw which is incorporated in one cylinder, is provided with a steel ball, this is normally

seated firmly on a valve opening in the cylinder. A dust cover is fitted over the screw nipple to exclude dirt and with the removal of this cover and an anti-clockwise turn of the screw the fluid may escape.

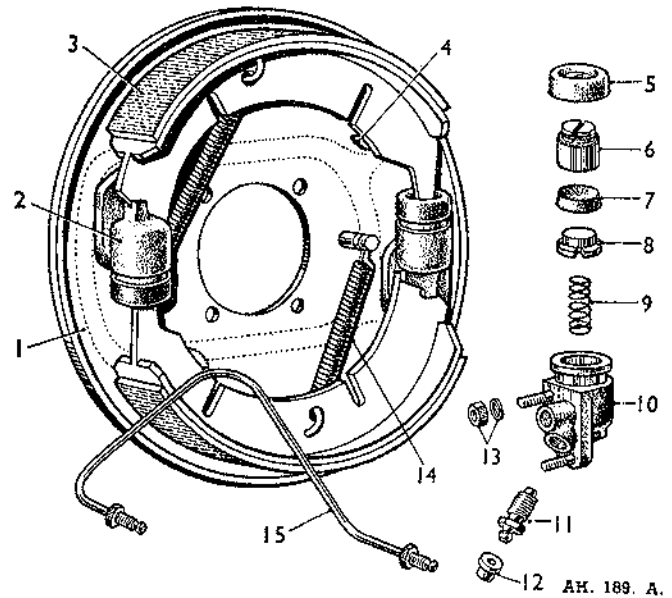

Fig. M.1. Front brake assembly.

- |                        |                               |
|------------------------|-------------------------------|
| 1. Backplate.          | 8. Seal support.              |
| 2. Wheel cylinder.     | 9. Spring.                    |
| 3. Shoe.               | 10. Cylinder housing.         |
| 4. Snail cam adjuster. | 11. Bleed screw.              |
| 5. Dust cover.         | 12. Bleed screw cover.        |
| 6. Piston.             | 13. Nut and washer.           |
| 7. Seal.               | 14. Shoe return spring.       |
|                        | 15. Cylinder connecting pipe. |

### Rear Brakes

The rear brake shoes are not fixed but are allowed to slide and centralise with the same effect as in the front brakes. They are hydraulically operated by a single acting wheel cylinder incorporating the handbrake mechanism. At the cylinder end the leading shoe is located in a slot in the piston while the trailing shoe rests in a slot formed in the cylinder body. At the adjuster end they rest in slots in the adjuster links. Both shoes are supported on the backplate and are held in position by two return springs fitted from shoe to shoe with the shorter spring nearer the adjuster.

The wheel cylinder consists of a light alloy die casting into the end of which moves a piston, with seal in a highly finished bore. In to the other end of the housing is machined a slot to carry the trailing shoe and at right angles projecting through the backplate is pivoted the handbrake lever. The cylinder is attached to the backplate by a spring clip allowing it to slide laterally.

A bleed screw is incorporated in the cylinder housing with a rubber dust cap over the nipple end.

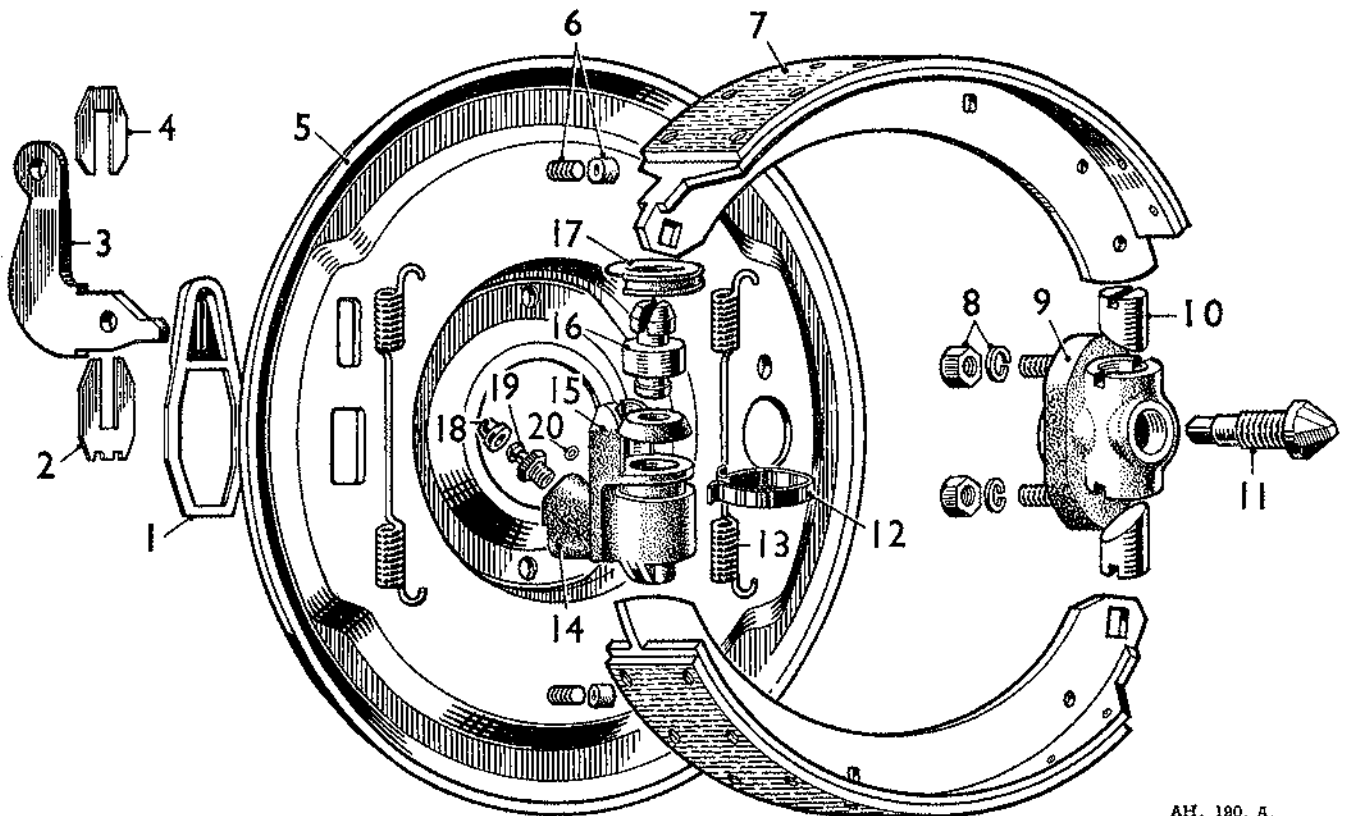

AH. 180. A.

Fig. M.2. Rear brake backplate exploded.

- |                                  |                           |                              |
|----------------------------------|---------------------------|------------------------------|
| 1. Rubber seal.                  | 8. Nut and spring washer. | 15. Cylinder body.           |
| 2. Wheel cylinder locking plate. | 9. Adjuster body.         | 16. Piston.                  |
| 3. Handbrake lever.              | 10. Adjuster tappets.     | 17. Dust cover.              |
| 4. Wheel cylinder locking plate. | 11. Adjuster wedge.       | 18. Bleed nipple dust cover. |
| 5. Backplate.                    | 12. Dust cover slip.      | 19. Dust cover shoulder.     |
| 6. Steady post.                  | 13. Shoe return spring.   | 20. Bleed nipple.            |
| 7. Brake shoe.                   | 14. Pipe orifice.         | 21. Bleed valve ball.        |

Adjustment for lining wear is made by the brake shoe adjuster. This has a steel housing which is spigotted and bolted firmly to the inside of the backplate. The housing carries two opposed steel links, the outer end slotted to carry the shoes, and the inclined inner faces bearing on inclined faces of the hardened steel wedge.

The wedge has a threaded spindle with a square end which projects on the outside of the backplate, enabling a spanner to be used for adjustment purposes, by rotating the wedge in a clockwise direction, the links are forced apart and the fulcrum of the brake shoes expanded.

When the brake is applied, the piston under the influence of the hydraulic pressure, moves the leading shoe and the body reacts by sliding on the backplate to operate the trailing shoe.

The handbrake lever is pivoted in the cylinder body, and when operated the lever tip expands the trailing shoe,

and the pivot moves the cylinder body and with it the piston to operate the leading shoe.

### Handbrake

The handbrake operates on the rear wheels only and is applied by a pull-up type of lever situated alongside the steering column cover. The cable from the control is attached to the compensator mounted on the rear axle. From compensator to the brake levers are transverse rods which are non-adjustable.

The handbrake linkage is set when leaving the works and should not require any attention. Only when a complete overhaul is necessary should the handbrake linkage require re-setting.

When this is correct the rear shoes should be locked to the drums, the handbrake control just slightly applied, and the cable slackness just removed, by means of adjusting the sleeve nut at the front end of the longitudinal rod.

## Section M.2

## MAINTENANCE

## Replenishment of Hydraulic Fluid

Inspect the supply tank at regular intervals and maintain at the indicated level by the addition of Girling Crimson Brake Fluid.

Great care should be exercised when adding brake fluid, to prevent dirt or foreign matter entering the system.

**Important.**—Serious consequences may result from the use of incorrect fluids, and on no account should any other than Girling Crimson Brake Fluid be used. This fluid has been specially prepared and is unaffected by high temperature or freezing.

## Bleeding the Hydraulic System

Bleeding is necessary any time a portion of the hydraulic system has been disconnected, or if the level of the brake fluid has been allowed to fall so low that air has entered the master cylinder.

With all the hydraulic connections secure and the supply tank topped up with the fluid, remove the rubber cap from the left hand rear bleed nipple and fit the bleed tube over the bleed nipple, immersing the free end of the tube in a clean jar containing a little brake fluid.

Unscrew the bleed nipple about three-quarters of a turn and then operate the brake pedal with a slow full stroke until the fluid entering the jar is completely free of air bubbles. Then, during a down stroke of the brake pedal, tighten the bleed screw sufficiently to seat the ball, remove bleed tube and replace the bleed nipple dust cap. **Under no circumstances must excessive force be used when tightening the bleed screws.**

This process must now be repeated for each bleed screw at each of the three remaining backplates, finishing at the wheel nearest the master cylinder. Always keep a careful check on the supply tank during bleeding, since it is most important that a full level is maintained. Should air reach the master cylinder from the supply tank, the whole of the bleeding operation must be repeated.

After bleeding, top up the supply tank to its correct level of approximately three-quarters full.

Never use fluid that has just been bled from a brake system for topping up the supply tank, as this brake fluid may be to some extent aerated. Such fluid must be allowed to stand for at least twenty-four hours before it is used again. This will allow the air bubbles in the fluid time to disperse.

Great cleanliness is essential when dealing with any part of the hydraulic system, and especially so where the brake fluid is concerned. Dirty fluid must never be added to the system.

**Note.**—It is advisable to turn all the brake shoe adjusters to their full “off” position before bleeding. After bleeding adjust brakes as described below.

## Adjusting the Brake Shoes

The brakes are adjusted for lining wear, **only** at the brakes themselves, and on no account should any alteration be made to the handbrake cable for this purpose.

**Front Brakes.** A separate snail cam adjuster is provided for each shoe. Jack up the car until the wheel to be adjusted is clear of the ground, then fully release both the hexagon head adjuster bolts on the outside of the backplate by turning anti-clockwise with an open-ended spanner.

Turn one of the adjuster bolts clockwise until the brake shoe concerned touches the brake drum, then release the adjuster until the shoe is just free of the drum. Repeat the process for the second adjuster and shoe.

Spin the wheel to ensure that the brake shoes are quite free of the drum. Repeat the whole procedure for the second front wheel.

**Rear Brakes.** One common adjuster is provided for both shoes and the adjustment of both rear wheels is identical.

Release the handbrake and jack up the car. Turn the square end of the adjuster on the outside of each

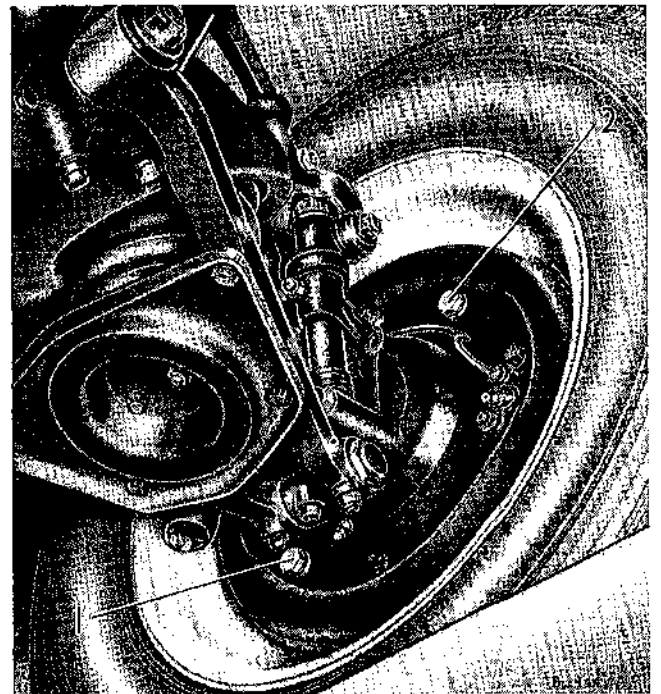

Fig. M.3. Showing the location of the two brake shoe adjusters on a front brake backplate.

rear brake backplate in a clockwise direction until a resistance is felt. Slacken two clicks when the drum should rotate freely.

### Section M.3

#### FRONT BRAKES

##### Replacing Brake Shoes

**Note.**—Always fit Girling "Factory Lined" replacement shoes. These have the correct type of lining and are accurately ground to size. When fitting replacement shoes, fit a new set of shoe return springs.

- (1) Jack up the car and remove road wheels, hub extensions and brake drums.
- (2) Lift one shoe out of the abutment slot of one wheel cylinder, then release from the piston slot of the other. (It will be found quite simple to remove the shoe return springs). To prevent the wheel cylinder pistons from expanding it is advisable to place a rubber band round each cylinder. Repeat with the second shoe.
- (3) Clean down the backplate, check wheel cylinders for leaks and freedom of motion.
- (4) Check adjusters for easy working and turn back (anti-clockwise) to full "off" position. Lubricate where necessary with **Girling (White) Brake Grease**.
- (5) Smear the tips of the brake shoe supports on the backplate, and the operating and abutment ends of the new shoes with **Girling (White) Brake Grease**. The (white) brake grease must not be allowed to contact hydraulic cylinders, pistons or rubber parts. Keep all grease off the linings on new replacement shoes and do not handle more than necessary.
- (6) Fit new shoe return springs to the new shoes. Place the hooked end of the spring through the hole in the shoe web and the swan neck through the hole in the back plate near the abutment end of the same shoe. Each shoe can be replaced independently. Remove rubber bands from cylinder.
- (7) Make sure the drums are clean and free from grease, etc., then re-fit.
- (8) Adjust the brakes as described under "Running Maintenance".
- (9) Re-fit the road wheels and lower the car to the ground.

### Section M.4

#### REAR BRAKES

##### Replacing Brake Shoes

Proceed in stages as described for front brakes, paragraphs 1 to 9, substituting the details in the following paragraphs for those bearing the same number.

M.4

- (2) Lift one of the shoes out of the slots in the adjuster link and wheel cylinder piston. Both shoes can then be removed complete with springs. Place a rubber band round the wheel cylinder to keep piston in place.
- (6) Fit the two new shoe return springs to the new shoes (with the shorter spring at adjuster end) from shoe to shoe and between shoe web and backplate. Locate one shoe in the adjuster link and wheel cylinder piston slots, then prise over the opposite shoe into its relative position. Remove rubber band.

**Note.**—The first shoe has the lining positioned towards the heel of the shoe and on the second shoe towards the toe or operating end in both left-hand and right-hand brake assemblies. Several hard applications of the brake pedal should be made to ensure all the parts are working satisfactorily and the shoes bedding to the drums, then the brakes should be adjusted as described.

Immediately after fitting replacement shoes it is advisable to slacken one further click on the brake adjuster to allow for possible lining expansion, reverting to normal adjustment afterwards.

### Section M 5

#### BRAKE PEDAL

##### To Remove

- (1) The brake and clutch pedal linkages are mounted in a common bracket and thus have to be released as a unit.
- (2) Inside the car disconnect the brake and clutch cylinder levers from their master cylinder push rods by removing the clevis pins.
- (3) Working under the bonnet, unscrew the six securing setpins sufficiently to allow the brake and clutch pedal linkage bracket to be withdrawn from inside the car.
- (4) Release the brake and clutch pedal return springs.

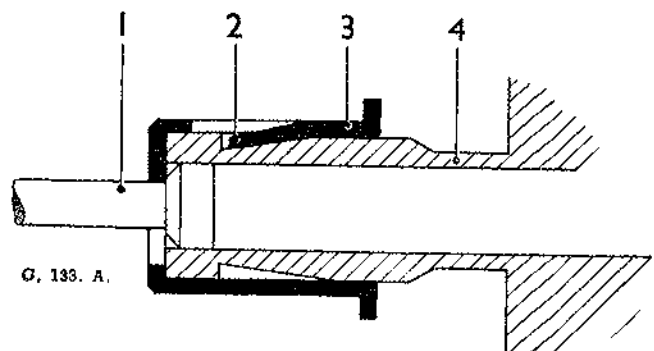
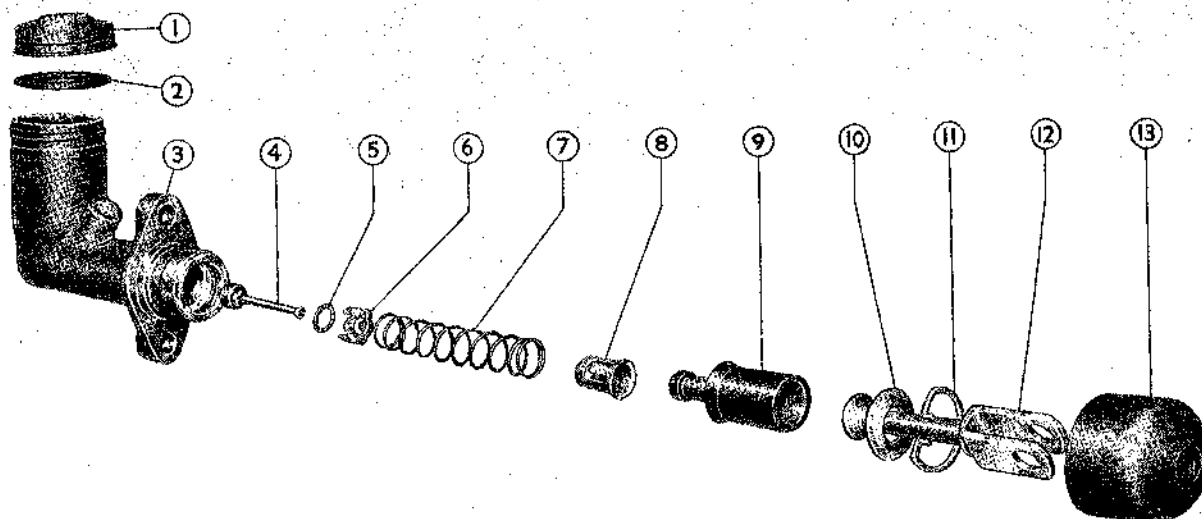

Fig. M.4. Diagrammatic section of master cylinder.

- |                  |             |
|------------------|-------------|
| 1. Valve stem.   | 3. Thimble. |
| 2. Thimble leaf. | 4. Plunger. |





G. 113. A.

Fig. M.5. Components of the master cylinder and reservoir.

- |                     |                   |                    |
|---------------------|-------------------|--------------------|
| 1. Filler cap.      | 5. Spring washer. | 10. Dished washer. |
| 2. Washer.          | 6. Valve spacer.  | 11. Circlip.       |
| 3. Master cylinder. | 7. Return spring. | 12. Fork.          |
| 4. Valve stem.      | 8. Thimble.       | 13. Dust cover.    |
|                     | 9. Plunger.       |                    |

- (5) Unscrew the nut securing the brake and clutch pedal shaft and withdraw the shaft to release the brake and clutch pedal levers together with their distance piece.
- (6) Inspect the lever bushes for wear and renew if necessary.

#### To Replace

Replacement is the reverse of the procedure "To Remove".

## Section M.6

### MASTER CYLINDER

#### Description

The master cylinder consists of an alloy body with a polished finish bore, and reservoir with cap. The inner assembly is made up of the push rod, dished washer, circlip, plunger, plunger seal, spring thimble, plunger return spring, valve spacer, spring washer, valve stem and valve seal. The open end of the cylinder is protected by a rubber dust cover.

#### Dismantling the Brake Master Cylinder

- (1) Release the master cylinder push rod from the brake pedal as described in Section M.5.
- (2) Disconnect the pressure pipe union from the cylinder and remove the securing bolts, then the

master cylinder and fluid reservoir may be withdrawn complete from the car.

- (3) Remove the filler cap and drain out the fluid. Pull back the rubber dust cover and remove the circlip with a pair of long nosed pliers. The push rod and dished washer can then be removed.
- (4) When the push rod has been removed the plunger with seal attached will be exposed ; remove the plunger assembly complete. The assembly can be separated by lifting the thimble leaf over the shouldered end of the plunger.
- (5) Depress the plunger return spring allowing the valve stem to slide through the elongated hole of the thimble thus releasing the tension on the spring.
- (6) Remove the thimble, spring and valve complete.
- (7) Detach the valve spacer, taking care not to lose the spacer spring washer which is located under the valve head. Remove the seal.
- (8) Examine all parts, especially the seals, for wear or distortion and replace with new parts where necessary.

#### Assembling the Brake Master Cylinder

- (1) Replace the valve seal so that the flat side is correctly seated on the valve head.
- (2) The spring washer should then be located with the dome side against the underside of the valve

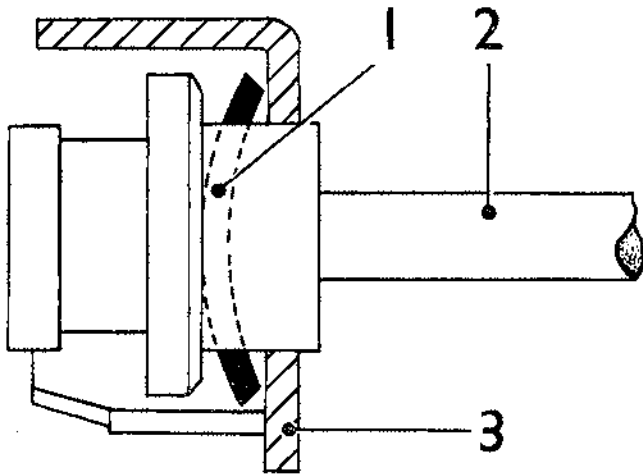

G. 134. A.

Fig. 7. Further section of master cylinder.

1. Washer. 2. Valve stem. 3. Valve spacer.

head, and held in position by the valve spacer, the legs of which face towards the valve seal.

- (3) Replace the plunger return spring centrally on the spacer, insert the thimble into the spring and depress until the valve stem engages through the elongated hole of the thimble, making sure the stem is correctly located in the centre of the

thimble. Check that the spring is still central on the spacer.

- (4) Refit a new plunger seal with the flat of the seal seated against the face of the plunger. Insert the reduced end of the plunger into the thimble until the thimble leaf engages under the shoulder of the plunger. Press home the thimble leaf.
- (5) Smear the assembly with the recommended brake fluid, and insert the assembly into the bore of the cylinder valve, end first, casing the plunger seal lips in the bore.
- (6) Replace the push rod with the dished side of the washer under the spherical head, into the cylinder followed by the circlip which engages into the groove machined in the cylinder body.
- (7) Replace the rubber dust cover and refit the whole unit into its aperture in the scuttle, not forgetting to fit the packing washer first. Secure the unit by means of the two bolts on the flange and refit the pressure pipe union into the cylinder.
- (8) Reconnect the push rod fork with its corresponding hole in the brake pedal lever, securing it with the circlip.
- (9) If no further maintenance to the brakes is necessary, remember to bleed the system.

### Section M.7

### FAULT DIAGNOSIS

Symptom	No.	Possible Fault
(a) Spongy Pedal (loss of fluid pressure)	1	Leak in system
	2	Master cylinder plunger worn
	3	Wheel cylinder leaking
	4	Air in system
	5	Lining not "down" on shoe
(b) Excessive Pedal Depression	1	In (a) check 1 and 4
	2	Excessive lining wear
	3	Extremely low brake fluid level Too much pedal free movement
(c) Brakes Grab or Pull to Side	1	Brake backplate loose on axle
	2	Scored, cracked or distorted drum
	3	High spots on drum
	4	Incorrect shoe adjustment
	5	Oily or wet linings
	6	Rear axle or front suspension anchorage loose
	7	Worn or loose rear spring anchorage
	8	Worn steering connections
	9	Different grades or types of lining fitted
	10	Uneven tyre pressures

## BRAKES

Symptom	No.	Possible Fault
(d) Dragging Brakes	1	In (c), check 3
	2	Wheel cylinder piston seized
	3	Weak or broken brake shoe return springs
	4	Master cylinder by-pass port restricted
	5	Too little pedal free movement
	6	Handbrake mechanism seized
	7	Supply tank overfilled Filler cap air vent choked
(e) Springy Pedal	1	Linings not "bedded-in"
	2	Brake drums weak or cracked
	3	Master cylinder fixing loose
(f) Brakes Inefficient	1	In (c), check 4 In (d), check 7 Incorrect type of linings fitted

### MODIFICATION REFERENCES

Service Reference Number	Date	Subject	Details of Changes



# SECTION N

## ELECTRICAL SYSTEM

Section No. N.1	General description
Section No. N.2	Battery
Section No. N.3	Preparing "dry charged" batteries for service
Section No. N.4	Preparing new unfilled, uncharged batteries for service
Section No. N.5	Generator
Section No. N.6	Maintenance
Section No. N.7	Testing in position to locate fault in charging circuit
Section No. N.8	Generator assembly
Section No. N.9	Inspection and overhaul
Section No. N.10	Assembling and replacing
Section No. N.11	The starter
Section No. N.12	Servicing the starter
Section No. N.13	Control box
Section No. N.14	Fuse unit
Section No. N.15	Flasher unit
Section No. N.16	Windscreen wipers
Section No. N.17	Ignition switch
Section No. N.18	Direction indicator warning lamp
Section No. N.19	Panel light bulbs
Section No. N.20	Headlamp main beam warning light bulb
Section No. N.21	Ignition warning light bulb
Section No. N.22	Fuel gauge
Section No. N.23	Overdrive switch
Section No. N.24	Panel lamps switch
Section No. N.25	Windscreen wiper switch
Section No. N.26	Lighting switch
Section No. N.27	Headlight bulbs
Section No. N.28	Headlamp beam setting
Section No. N.29	Replacing a light unit
Section No. N.30	Headlamp dipping switch
Section No. N.31	Horn push and direction indicator switch
Section No. N.32	Combined side and flasher lights bulb
Section No. N.33	Combined stop/tail and flasher lights bulbs
Section No. N.34	Rear number plate light bulb
Section No. N.35	Fault diagnosis

---



## Section N.1

### GENERAL DESCRIPTION

This vehicle is equipped with a 12-volt positive earth return system with single pole wiring. The generator output is regulated by the compensated voltage control system. A fuse box incorporates two fuses which protect such units within the auxiliary circuits. High-tension current for the ignition system is generated in a coil and conveyed to the sparking plugs through a distributor. Automatic advance and retard of the ignition timing is controlled by a centrifugal advance mechanism in the distributor combined with a vacuum-operated unit. For detailed descriptions of each unit see the relative paragraph under these headings in subsequent pages.

## Section N.2

### BATTERY

#### Description

The battery is a 12-volt lead-acid type, having six cells, each cell consisting of a group of positive and negative plates immersed in a solution of sulphuric acid (electrolyte).

The battery has three functions :—

- (1) To supply current for starting, ignition and lighting.
- (2) To provide a constant supply of current to the electrical equipment under normal operating conditions and when the consumption of the electrical equipment exceeds the output of the generator.
- (3) To control the voltage of the electrical supply system.

It is necessary that the current demand from the battery should be balanced by the generator output whilst the vehicle is being operated, otherwise the battery will deteriorate. The average input charge should therefore slightly exceed the average discharge to maintain the battery in a fully charged condition.

The battery does not actually store electricity; its action is chemical. Current introduced into the battery by the generator is converted into chemical energy. By completing a circuit between the positive and negative terminals, the chemical energy is transformed and will flow from the battery in the form of electric current.

#### Adjustments in the Vehicle

The purpose of the following operations is to maintain the performance of the battery at its maximum.

- (1) The battery and the surrounding parts should be kept dry and clean, particularly the tops of the cells as any dampness could cause a leakage between the securing strap and the battery negative terminal, resulting in a partially discharged battery. Clean off any corrosion from the battery

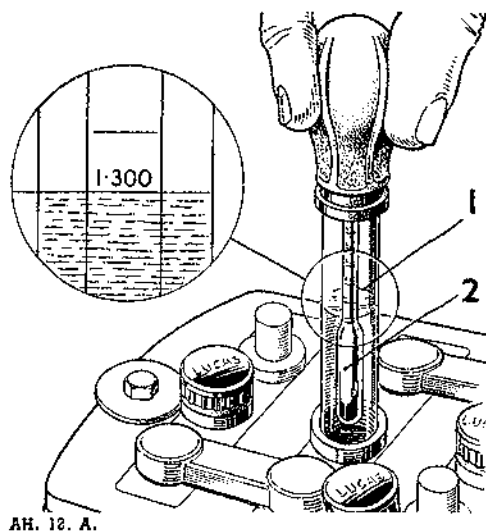

Fig. N.1.

Using a hydrometer to test the specific gravity of the battery acid.  
1. Reading. 2. Float.

- bolts, strap and tray with diluted ammonia, afterwards painting the affected parts with anti-sulphuric paint.
- (2) Remove the vent plugs and check that they are not perished or cracked, otherwise leakage of electrolyte will occur. Clean out the vent holes, if necessary, with a piece of wire.
- (3) The electrolyte levels should be maintained **just above** the tops of the separators by adding distilled water. Never add acid.
- (4) Check the terminal posts. If they are corroded, remove the cables and clean with diluted ammonia. Smear the posts with petroleum jelly before remaking the connections and ensure that the cable terminal clamp bolts are secure. Do not overtighten the clamp bolts.
- (5) Test the condition of the battery cells by using a hydrometer (see Fig. N.1).

#### To Remove

- (1) Raise the boot lid to gain access to the battery.
- (2) Disconnect both cables from the battery.
- (3) Release the battery clamp and lift out the battery.

#### To view

- (1) Place the battery on a lead-covered bench, or on a wooden bench the top of which has been treated with anti-sulphuric paint.
- (2) Check the electrolyte levels.
- (3) Inspect the container for cracks, which may be indicated by external corrosion or extreme variations of electrolyte levels. A cracked container must be renewed.

- (4) Test the condition of the battery cells by using a hydrometer (see Fig. N.1).

All readings should be uniform. The hydrometer values given in the "General Data" indicate the state of charge of the battery.

- (5) If the electrolyte level is below the tops of the separators, it will not be possible to withdraw a sufficient amount to raise the hydrometer float. In such circumstances a high-rate discharge tester should be used.

**Note.**—The use of a discharge tester is not recommended for normal testing, but only where a hydrometer reading cannot be obtained due to an excessively low electrolyte level.

#### Charging from an External Source

The length of time for a used battery to remain on charge before it can be accepted as fully charged depends entirely on the specific gravity before charging commences and the charging rate. The charging should continue until all cells are gassing freely and evenly and the specific gravity in each of the six cells has reached a maximum, i.e. has shown no further rise in four hours. The specific gravity at the end of charging should be within the limits given in the "General Data", and should not vary .005 (5 points) from the values given.

Do not allow the temperature of the electrolyte to exceed the maximum permissible temperature, i.e. 120°F. (49°C.). If this temperature is reached the charge should be suspended to allow the temperature to fall at least 10°, otherwise the life of the battery will tend to be shortened.

#### To Install

The installation of the battery is a reversal of the procedure "To remove". Smear the terminal posts and cable connections with petroleum jelly and tighten the clamp bolts sufficiently to prevent the cables from moving on the terminal posts when tested by hand, but do not overtighten.

### Section N.3

#### PREPARING "DRY-CHARGED" BATTERIES FOR SERVICE

"Dry-charged" batteries are supplied without electrolyte but with the plates in a charged condition. When they are required for service it is only necessary to fill each cell with sulphuric acid of the correct specific gravity. No initial charging is required. This procedure ensures that there is no deterioration of the efficiency of the battery during the storage period before the battery is required for use.

In these batteries porous rubber is used instead of wood for the separators between the plates.

N.2

#### Preparation of Electrolyte

The electrolyte is prepared by mixing together distilled water and concentrated sulphuric acid, taking the precautions given in Section N.4. The specific gravity of the filling electrolyte depends on the climate in which the battery is to be used (see "General Data").

The approximate proportions of acid and water are indicated in the following table :

To obtain Specific Gravity (corrected to 60°F.) of :	Add 1 vol. of acid of 1.835 S.G. (corrected to 60°F.) to:
1.27	2.9 volumes of water
1.21	4.0 volumes of water

Heat is produced by the mixture of acid and water, and the electrolyte should be allowed to cool before pouring it into the battery.

The total volume of electrolyte required can be estimated from the figures quoted under "General Data".

#### Filling the Battery

Carefully break the seals in the cell filling holes and fill each cell with electrolyte to the top of the separators, *in one operation*. The temperature of the filling room, battery and electrolyte should be maintained between 60° and 100°F. (15.6° and 37.8°C.). If the battery has been stored in a cool place, it should be allowed to warm up to room temperature before filling.

#### Putting into Use

Batteries filled in this way are 90 per cent. charged, and capable of giving a starting discharge *one hour after filling*. When time permits, however, a short freshening charge will ensure that the battery is fully charged. Such a freshening charge should last for no more than 4 hours, at the normal re-charge rate of the battery.

During the charge the electrolyte must be kept level with the top edge of the separators by the addition of distilled water. Check the specific gravity of the acid at the end of the charge; if 1.27 acid was used to fill the battery, the specific gravity should now be between 1.27 and 1.29; if 1.21, between 1.21 and 1.23. After filling, a dry-charged battery needs only the attention normally given to a lead-acid battery.

### Section N.4

#### PREPARING NEW UNFILLED, UNCHARGED BATTERIES FOR SERVICE

#### Preparation of Electrolyte

Batteries should not be filled with acid until required for initial charging. Electrolyte of the specific gravity given under "General Data" is prepared by mixing distilled water and concentrated sulphuric acid,



usually of 1.835 S.G. The mixing must be carried out either in a lead-lined tank or in suitable glass or earthenware vessels. Slowly add the acid to the water, stirring with a glass rod. **Never add the water to the acid**, as the resulting chemical reaction causes violent and dangerous spurting of the concentrated acid. The approximate proportions of acid and water are indicated in the following table :

To obtain Specific Gravity (corrected to 60°F.) of:	Add 1 vol. of acid of 1.835 S.G. (corrected to 60°F.) to:
1.34	2.0 volumes of water
1.29	2.7 volumes of water

Heat is produced by the mixture of acid and water, and the electrolyte should be allowed to cool before taking hydrometer readings—unless a thermometer is used to measure the actual temperature, and a correction applied to the reading as described under “General Data” and before pouring the electrolyte into the battery.

The total volume of electrolyte required can be estimated from the figures quoted under “General Data”.

#### Filling the Battery

The temperature of the acid, battery and filling room must not be below 32°F. (0°C.).

Carefully break the seals in the filling holes and *half-fill* each cell with electrolyte of the appropriate specific gravity. Allow the battery to stand for at least six hours, in order to dissipate the heat generated by the chemical action of the acid on the plates and separators, and then add sufficient electrolyte to fill each cell to the top of the separators. Allow to stand for a further two hours and then proceed with the initial charge.

#### Initial Charge

The initial charging rate is given under “General Data”. Charge at this rate until the voltage and specific gravity readings show no increase over five successive hourly readings. This will take from 40 to 80 hours, depending on the length of time the battery has been stored before charging.

Keep the current constant by varying the series resistance of the circuit or the generator output. *This charge should not be broken by long rest periods.* If, however, the temperature of any cell rises above the permissible maximum quoted, the charge must be interrupted until the temperature has fallen at least 10°F. (5.5°C.) below that figure. Throughout the charge, the electrolyte must be kept level with the top of the separators by the addition of acid solution of the same specific gravity as the original filling-in acid, until

specific gravity and voltage readings have remained constant for five successive hourly readings. If the charge is continued beyond that point, top-up with distilled water.

At the end of the charge carefully check the specific gravity in each cell to ensure that, when corrected to 60°F. (15.6°C.) it lies within the specified limits. If any cell requires adjustment, some of the electrolyte must be siphoned off and replaced either by distilled water or by acid of the strength originally used for filling-in, depending on whether the specific gravity is too high or too low. Continue the charge for an hour or so to ensure adequate mixing of the electrolyte and again check the specific gravity readings. If necessary, repeat the adjustment process until the desired reading is obtained in each cell. Finally, allow the battery to cool, and siphon off any electrolyte above the tops of the separators.

## Section N.5

### GENERATOR

#### Description

The generator is a shunt-wound two-pole two-brush machine, arranged to work in conjunction with a compensated voltage control regulator unit. A fan, integral with the driving pulley, draws cooling air through the generator, inlet and outlet holes being provided in the end brackets of the unit.

The output of the generator is controlled by the regulator and is dependent on the state of charge of the battery and the loading of the electrical equipment in use. When the battery is in a low state of charge, the generator gives a high output, whereas if the battery is fully charged, the generator gives only sufficient output to keep the battery in good condition without any possibility of overcharging. In addition, an increase in output is given to balance the current taken by lamps and other accessories when in use. Further, a high boosting charge is given for a few minutes immediately after starting up, thus quickly restoring to the battery the energy taken from it by the electric starting motor.

## Section N.6

### MAINTENANCE

#### Lubrication

Every 12,000 miles (20000 km.) inject a few drops of medium viscosity (S.A.E.30) engine oil into the hole marked “oil” at the end of the bearing housing.

#### Inspection of Brushgear and Commutator

Every 12,000 miles (20000 km.) inspect the brushgear and commutator. Access to the brushgear on earlier generators is gained by removing the metal band

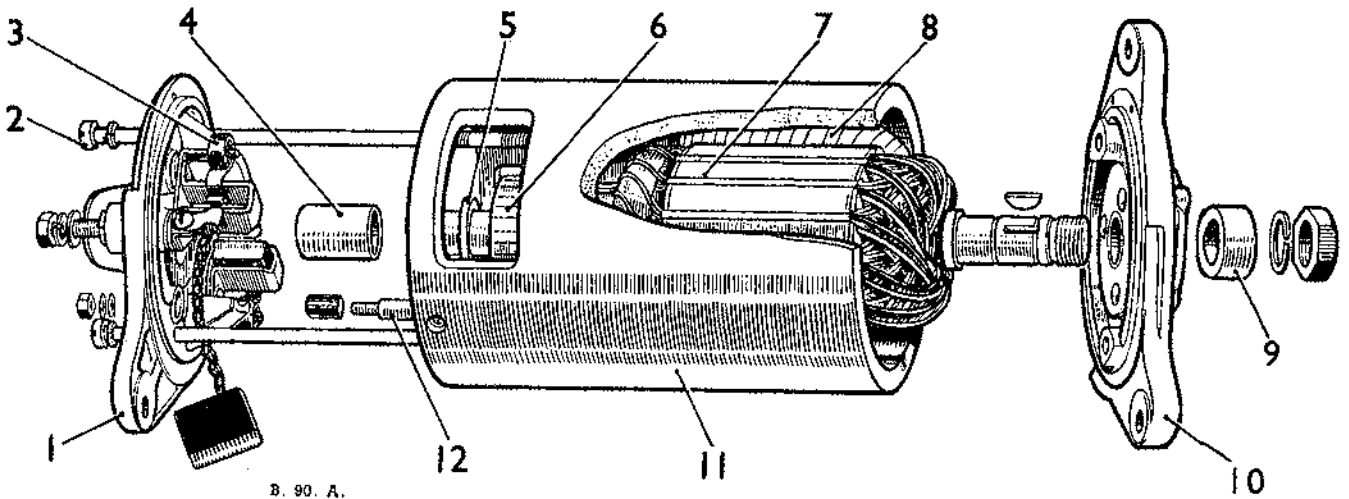

Fig. N.2. The generator exploded.

1. Commutator end bracket.  
2. Through bolt.  
3. Brush spring.

4. Brush.  
5. Thrust collar.  
6. Commutator.

7. Armature.  
8. Field coil.  
9. Distance collar.

10. Drive end bracket.  
11. Yoke.  
12. Field terminal post.

cover from around the yoke. Some generators are now produced without brushgear inspection windows in the yoke and it is necessary to unscrew the two through bolts and withdraw the commutator end bracket before access to the brushgear can be gained.

Check that the brushes move freely in their holders by holding back the brush springs and pulling gently on the flexible connectors. If a brush is inclined to stick, remove it from its holder and clean its sides with a petrol-moistened cloth. Be careful to replace brushes in their original positions in order to retain the "bedding". Brushes which have worn so that they will not "bed" properly on the commutator must be renewed.

The commutator should be clean, free from oil or dirt, and should have a polished appearance. If it is dirty, clean it by pressing a fine dry cloth against it while the engine is slowly turned over by hand. If the commutator is very dirty, moisten the cloth with petrol.

### Belt Adjustment

Occasionally inspect the generator driving belt and adjust if necessary to take up any undue slackness by turning the generator on its mounting. Care should be taken to avoid overtightening the belt, which should have sufficient tension only to drive without slipping.

See that the generator is properly aligned, otherwise undue strain will be thrown on the bearings.

## Section N.7

### TESTING IN POSITION TO LOCATE FAULT IN CHARGING CIRCUIT

In the event of a fault in the charging circuit, adopt the following procedure to locate the cause of the trouble.

- (1) Inspect the driving belt and adjust if necessary.
- (2) Check that the generator and control box are connected correctly. The larger generator terminal must be connected to control box terminal "D", and the smaller generator terminal to control box terminal "F". Check the control box terminal "E" and associated earthing cable for tightness.
- (3) Switch off all lights and accessories, disconnect the cables from the generator terminals and connect the two terminals with a short length of wire.
- (4) Start the engine and set to run at normal idling speed.
- (5) Clip the negative lead of a moving coil voltmeter, calibrated 0 to 20 volts, to one generator terminal, and the other lead to a good earthing point on the yoke.
- (6) Gradually increase the engine speed, when the voltmeter reading should rise rapidly without fluctuation. Do not allow the voltmeter reading to reach 20 volts and do not race the engine in an attempt to increase the voltage. It is sufficient to run the generator up to a speed of 1,000 r.p.m. If there is no reading, check the brushgear as described in (7) below.

If there is a low reading of approximately  $\frac{1}{2}$  to 1 volt, the field winding may be at fault (see "Field Coils"). If there is a reading of 4 to 5 volts, the armature winding may be at fault (see "Armature").

**Note.**—Excessive sparking at the commutator in the above test indicates a defective armature which should be replaced.

- (7) Remove the cover band (when fitted) and examine the brushes and commutator. Hold back each of the brush springs and move the brush by pulling gently on its flexible connector. If the movement is sluggish, remove the brush from its holder and ease the sides by lightly polishing on a smooth file. Always replace brushes in their original position.

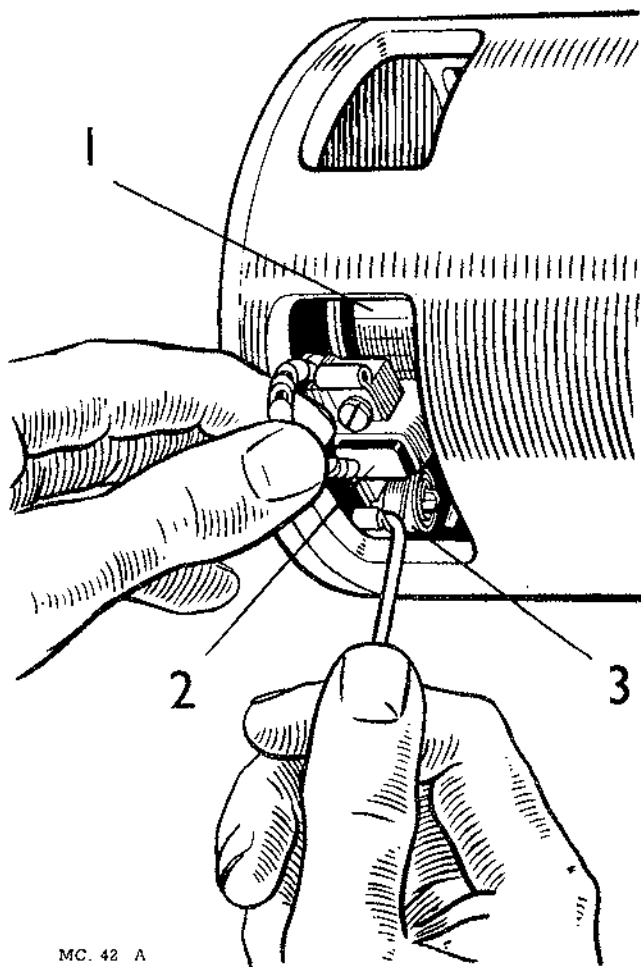

MC. 42 A

Fig. N.3. Removing a generator brush from its holder.  
1. Commutator. 2. Brush. 3. Brush spring.

If the brushes are badly worn, new brushes must be fitted and bedded to the commutator. The minimum permissible length of brush is  $\frac{1}{16}$  in.

Test the brush spring tension with a spring scale. The tension of the springs when new is 36 to 44 oz. In service it is permissible for this value to fall to 30 oz. before performance may be affected. Fit new springs if the tension is low. If the commutator is blackened or dirty, clean it by holding a petrol moistened cloth against it while the engine is turned slowly by hand cranking.

Re-test the generator as in (6); if there is still no reading on the voltmeter there is an internal fault and the complete unit, if a spare is available, should be replaced. Otherwise the unit must be dismantled for internal examination.

When reassembling a "windowless" yoke generator, the brushes must first be held clear of the commutator in the usual way, i.e., by partially withdrawing the brushes from their brush-boxes until each brush is trapped in position by the side pressure of its spring. The brushes can be released on to the commutator with a small screwdriver or similar tool when the end bracket is assembled to within about half-an-inch of the yoke. Before closing the gap between end bracket and yoke, see that the springs are in correct contact with the brushes.

- (8) If the generator is in good order, remove the link from between the terminals and restore the original connections, taking care to connect the larger generator terminal to control box terminal "D", and the smaller terminal to control box terminal "F".

## Section N.8

### GENERATOR ASSEMBLY

#### To remove

- (1) Disconnect the two leads to the generator.
- (2) Disconnect the high tension lead and the two low tension leads to the coil.
- (3) Slacken the nut securing the sliding link and the two bolts holding the generator to its mounting bracket.
- (4) Push the generator downwards to slacken the fan belt so that the latter can then be removed.
- (5) Remove the setpin from the upper end of the sliding link and take out the nuts and bolts from the mounting bracket.
- (6) Lift the generator clear of the engine.
- (7) Unscrew the two nuts securing the coil to its bracket on the generator and remove the coil.

#### To Dismantle

- (1) Take off the driving pulley.
- (2) On earlier type generators, remove the cover

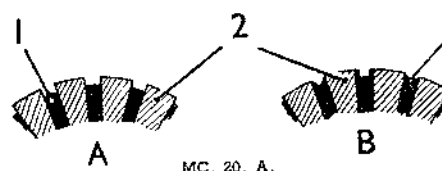

MC. 20. A.

Fig. N.4. Undercutting the commutator.  
'A' is the correct and 'B' the incorrect method.  
1. Insulation. 2. Segments.

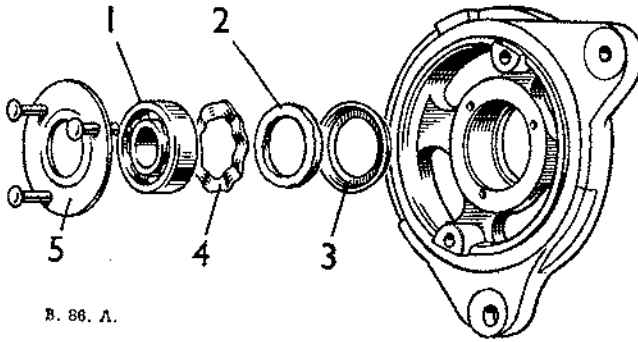

B. 86. A.

Fig. N.5. Generator drive end bracket.

- |                             |                          |
|-----------------------------|--------------------------|
| 1. Bearing.                 | 3. Oil retaining washer. |
| 2. Felt washer.             | 4. Corrugated washer.    |
| 5. Bearing retaining plate. |                          |

band, hold back the brush springs and remove the brushes from their holders.

- (3) Unscrew and withdraw the two through bolts.
- (4) The commutator end bracket can now be withdrawn from the generator yoke.
- (5) The driving end bracket together with the armature can now be lifted out of the yoke.
- (6) The driving end bracket, which on removal from the yoke has withdrawn with it the armature and armature shaft ball bearing, need not be separated from the shaft unless the bearing is suspected and requires examination, or the armature is to be replaced; in this event the armature should be removed from the end bracket by means of a hand press.

## Section N.9

### INSPECTION AND OVERHAUL

#### Commutator

A commutator in good condition will be smooth and free from pits or burned spots. Clean the commutator with a petrol-moistened cloth. If this is ineffective, carefully polish with a strip of fine glass paper while rotating the armature.

To remedy a badly worn commutator mount the armature, with or without the drive end bracket, in a lathe, then rotate at high speed and take a light cut with a very sharp tool. Do not remove more metal than is necessary. Polish the commutator with very fine glass paper. Undercut the insulators between the segments to a depth of  $\frac{1}{32}$  in. (.8 mm.) with a hacksaw blade ground to the thickness of the insulator.

The most common armature faults are usually confined to open or short-circuited windings. Indication of an open-circuited armature winding is given by burnt commutator segments. A short-circuited armature

N.6

winding is easily identified by discolouration of the overheated windings and badly burned commutator segments.

If armature testing facilities are not available, an armature can be checked by substitution.

To remove the armature shaft from the drive end bracket and bearing, support the bearing retaining plate firmly and press the shaft out of the drive end bracket. When fitting the new armature, support the inner journal of the ball bearing, using a mild steel tube of suitable diameter, whilst pressing the armature shaft firmly home. The mild steel tubes should be approximately 4 in. long and  $\frac{1}{4}$  in. thick, the internal diameter being  $\frac{1}{16}$  in.

**Do not use the drive end bracket as a support for the bearing whilst fitting an armature.**

#### Field Coils

Measure the resistance of the field coils, without removing them from the general yoke, by means of an ohmmeter connected between the field terminal and the yoke.

The ohmmeter should read 6 ohms approximately.

If an ohmmeter is not available, connect a 12-volt d.c. supply with an ammeter in series between the field terminal and generator yoke. The ammeter reading should be approximately 2 amperes. Zero on the ammeter or an "Infinity" ohmmeter reading indicates an open-circuit in the field winding.

If the current reading is much more than 2 amperes, or the ohmmeter reading much below 6 ohms, it is an indication that the insulation of one of the field coils has broken down.

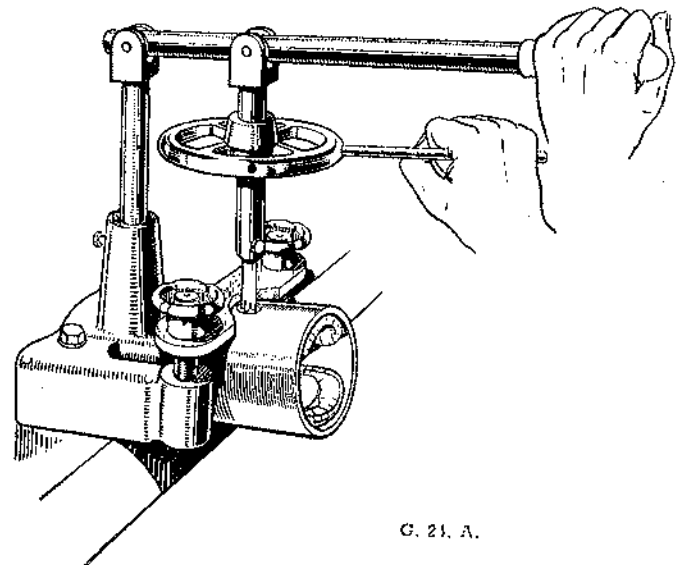

G. 21. A.

Fig. N.6. Using the wheel operated screwdriver.

In either case, unless a substitute generator is available, the field coils must be replaced. To do this, carry out the procedure outlined below :—

- (1) Drill out the rivet securing the field coil terminal assembly to the yoke, and unsolder the field coil connections.
- (2) Remove the insulation piece which is provided to prevent the junction of the field coils from contacting with the yoke.
- (3) Mark the yoke and pole shoes in order that they can be refitted in their original positions.
- (4) Unscrew the two pole shoe retaining screws by means of the wheel-operated screwdriver.
- (5) Draw the pole shoes and coils out of the yoke and lift off the coils.
- (6) Fit the new field coils over the pole shoes and place them in position inside the yoke. Take care to ensure that the taping of the field coils is not trapped between the pole shoes and the yoke.
- (7) Locate the pole shoes and field coils by lightly tightening the fixing screw.
- (8) Fully tighten the screws by means of the wheel-operated screwdriver and lock them by caulking.
- (9) Replace the insulation piece between the field coil connections and the yoke.
- (10) Re-solder the field coil connections to the field coil terminal tags and re-rivet the terminal assembly to the yoke.

### Bearings

Bearings which have worn to such an extent that they will allow side movement of the armature shaft must be replaced.

To replace the bearing bush in a commutator end bracket, proceed as follows :—

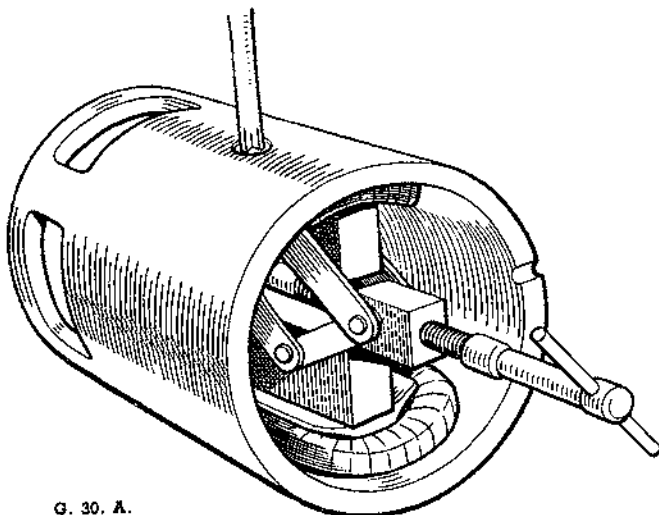

Fig. N.7. Showing the pole shoe expander in position.

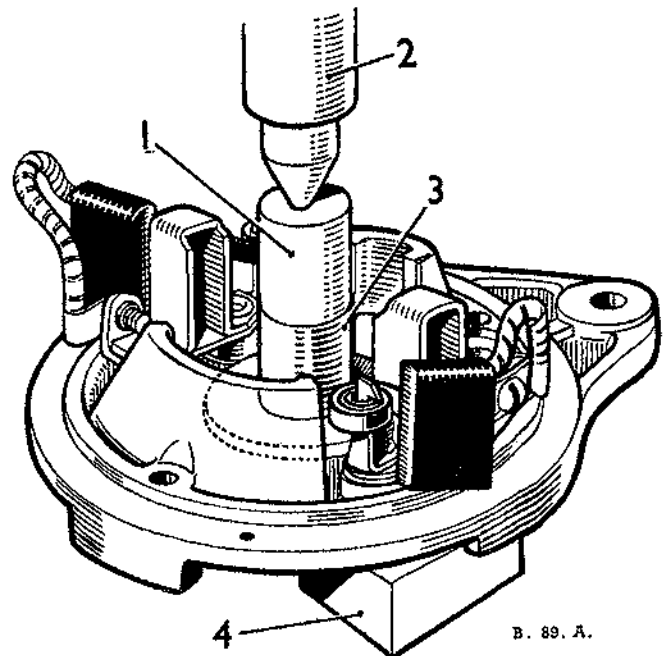

Fig. N.8. Fitting a new bush to the generator commutator end bracket.

- |                        |                      |
|------------------------|----------------------|
| 1. Shouldered mandrel. | 3. Bearing bush.     |
| 2. Hand press.         | 4. Supporting block. |

- (1) Remove the old bearing bush from the end bracket. The bearing can be withdrawn with a suitable extractor or by screwing a tap into the bush for a few turns and pulling out the bush with the tap. Use an  $\frac{11}{16}$  in. tap. Screw the tap squarely into the bush to avoid damaging the bracket.
- (2) Insert the felt ring and aluminium disc in the bearing housing, then press the new bearing bush into the end bracket, using a shouldered, highly polished mandrel of the same diameter as the shaft which is to fit in the bearing, until the visible end of the bearing is flush with the inner face of the bracket. Porous bronze bushes must not be opened out after fitting, or the porosity of the bush may be impaired.

**Note.**—Before fitting the new bearing bush it should be allowed to stand for 24 hours completely immersed in thin (S.A.E.20) engine oil; this will allow the pores of the bush to be filled with lubricant. In cases of extreme urgency, this period may be shortened by heating the oil to 100°C. (212°F.), for two hours then allowing to cool before removing the bearing bush.

The ball bearing at the driving end is replaced as follows :—

- (1) Drill out the rivets which secure the bearing retaining plate to the end bracket and remove the plate.

- (2) Press the bearing out of the end bracket and remove the corrugated washer, felt washer and oil retaining washer.
- (3) Before fitting the replacement bearing see that it is clean and pack it with high melting point grease.
- (4) Place the oil retaining washer, felt washer and corrugated washer in the bearing housing in the end bracket.
- (5) Locate the bearing in the housing and press it home. The outer bearing journal is a light push-fit in the bearing housing.
- (6) Refit the bearing retaining plate using rivets having the same dimensions as those originally fitted. Use Lucas No. 188739 for the end brackets.

**Note.**—When fitting a drive end bracket to the armature shaft, the inner journal of the bearing must be supported by a mild steel tube. This tube should be approximately 4 in. (10 cm.) long and  $\frac{1}{8}$  in. (3.175 mm.) thick, with an internal diameter of  $\frac{11}{16}$  in. (17.46 mm.). Do not use the drive end bracket as a support for the bearing when fitting an armature.

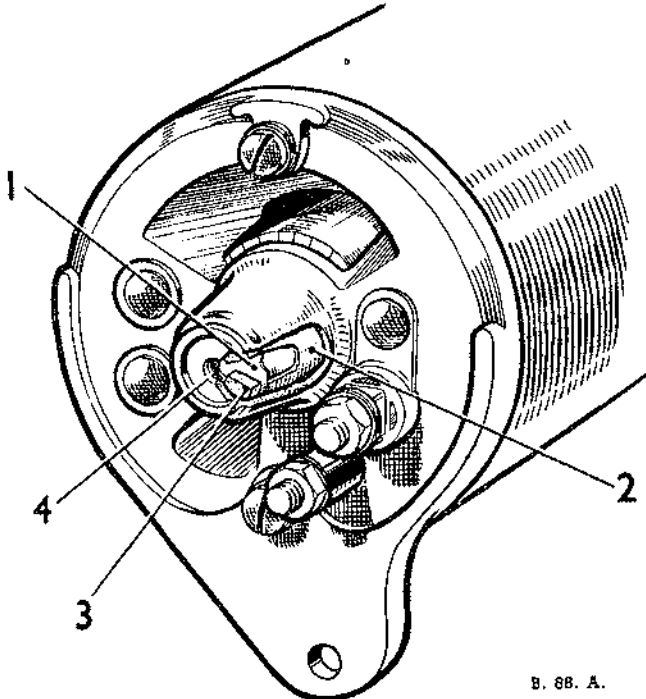

Fig. N.9. generator lubrication.

- |                        |               |
|------------------------|---------------|
| 1. Aluminium disc.     | 3. Felt ring. |
| 2. Porous bronze bush. | 4. Oil hole.  |

## Section N.10

### ASSEMBLING AND REPLACING

In the main the reassembly of the generator is a reversal of the dismantling procedure. Before refitting

N.8

the generator, however, inject S.A.E.30 oil into the commutator end bracket as previously described. The replacement is the reverse of the procedure "To Remove" in Section N.8. Check the fan belt adjustment as described in Section C.

## Section N.11

### THE STARTER

#### To Test on Vehicle

- (1) Switch on the lamps and operate the starter control. If the lights go dim, but the starter is not heard to operate, an indication is given that current is flowing through the starter windings but that the starter pinion is meshed permanently with the geared ring on the flywheel. This was probably caused by the starter being operated while the engine was still running. In this case the starter must be removed from the engine for examination.
- (2) Should the lamps retain their full brilliance when the starter switch is operated, check that the switch is functioning. If the switch is in order, examine the connections at the battery, starter switch and starter, and also check the wiring between these units. Continued failure of the starter to operate indicates an internal fault, and the starter must be removed from the engine for examination.

Sluggish action of the starter is usually caused by a poor connection in the wiring which produces a high resistance in the starter circuit. Check as described above.

Damage to the starter drive is indicated if the starter is heard to operate but does not crank the engine.

## Section N.12

### SERVICING THE STARTER

#### To Remove and Replace

Release the starter cable from the terminal and unscrew the two starter securing bolts. Manoeuvre the starter forwards below the oil filter and lift clear of the engine.

#### Examination of Commutator and Brush Gear

- (1) Remove the starter cover band and examine the brushes and the commutator.
- (2) Hold back each of the brush springs and move the brush by pulling gently on its flexible connector. If the movement is sluggish remove the brush from its holder and ease the sides by lightly polishing on a smooth file. Always replace brushes in their original positions. If the brushes are worn so that they no longer bear on the

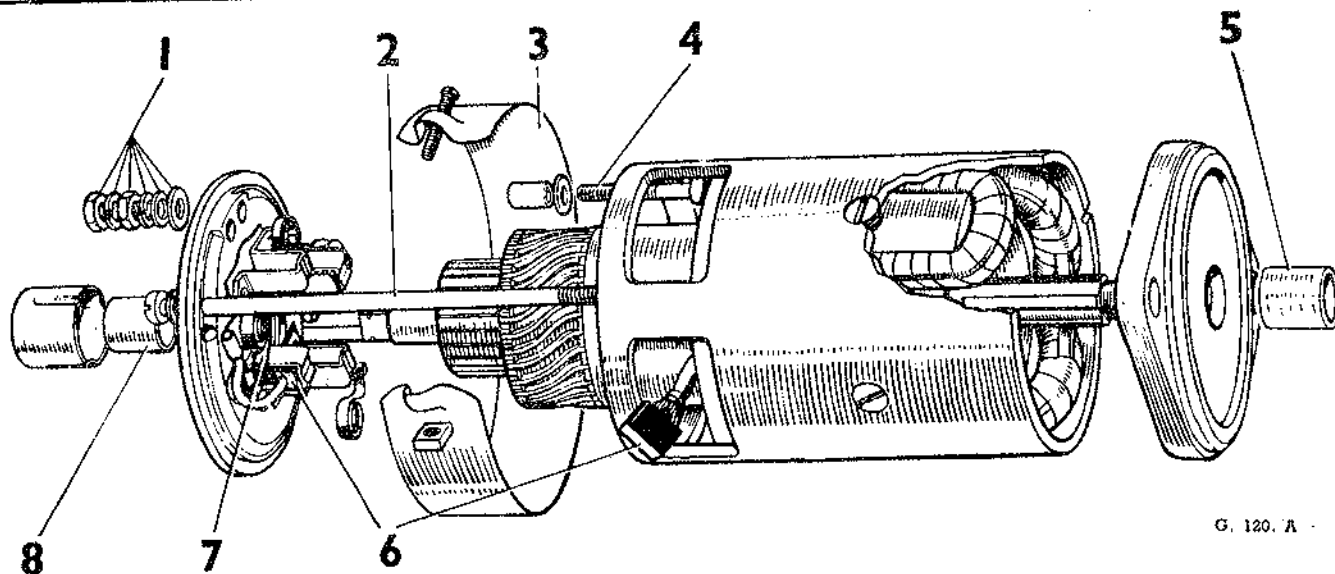

G. 120. A

Fig. N.10. Starter in exploded form.

- |                               |                  |
|-------------------------------|------------------|
| 1. Terminal nuts and washers. | 5. Bearing bush. |
| 2. Through bolt.              | 6. Brushes.      |
| 3. Cover band.                | 7. Brush spring. |
| 4. Terminal post.             | 8. Bearing bush. |

commutator, or if the brush flexible lead has become exposed on the running face, they must be renewed.

- (3) If the commutator is blackened or dirty, clean it by holding a petrol-moistened cloth against it while the armature is rotated.
- (4) Secure the body of the starter in a vice and test by connecting it with heavy-gauge cables to a 12-volt battery. One cable must be connected to the starter terminal and the other held against the starter body or end bracket. Under these light load conditions the starter should run at a very high speed.

If the operation of the starter is still unsatisfactory, it should be dismantled for detailed inspection and testing.

#### To Dismantle

- (1) Take off the cover band at the commutator end, hold back the brush springs and take out the brushes.
- (2) Extract the split pin at the driving end and remove the nut (left-hand thread), spring, washer, pinion and sleeve, restraining spring and collar and spring sleeve.
- (3) Remove the terminal nuts and washers from the terminal post and screw out the two through-bolts.
- (4) Remove the commutator end bracket, the attachment bracket and the armature.

#### Brushes

- (1) Test the brush springs with a spring balance.

The correct tension is 30 to 40 ozs. (850 to 1134 gm.). Fit a new spring if the tension is low.

- (2) If the brushes are worn so that they no longer bear on the commutator, or if the flexible connector has become exposed on the running face, they must be renewed. Two of the brushes are connected to terminal eyelets attached to the brush boxes on the commutator end bracket. The other two brushes (Fig. N.12) are connected to tappings on the field coils.

The flexible connectors must be removed by unsoldering and the connectors of the new brushes secured in their place by soldering. The brushes are pre-formed, so that bedding of the working face to the commutator is unnecessary.

#### Drive

- (1) If the pinion is tight on the screwed sleeve, wash away any dirt with paraffin (kerosene).
- (2) If any parts are worn or damaged they must be renewed.
- (3) Remove the cotter pin from the shaft nut at the end of the starter drive. Hold the squared starter shaft extension at the commutator end by means of a spanner and unscrew the square shaft nut. Lift off the main spring, washer, screwed sleeve with pinion, collar, pinion restraining spring and spring restraining sleeve.

#### Commutator

A commutator in good condition will be smooth and free from pits and burned spots. Clean the commutator with a cloth moistened with petrol (gasoline).

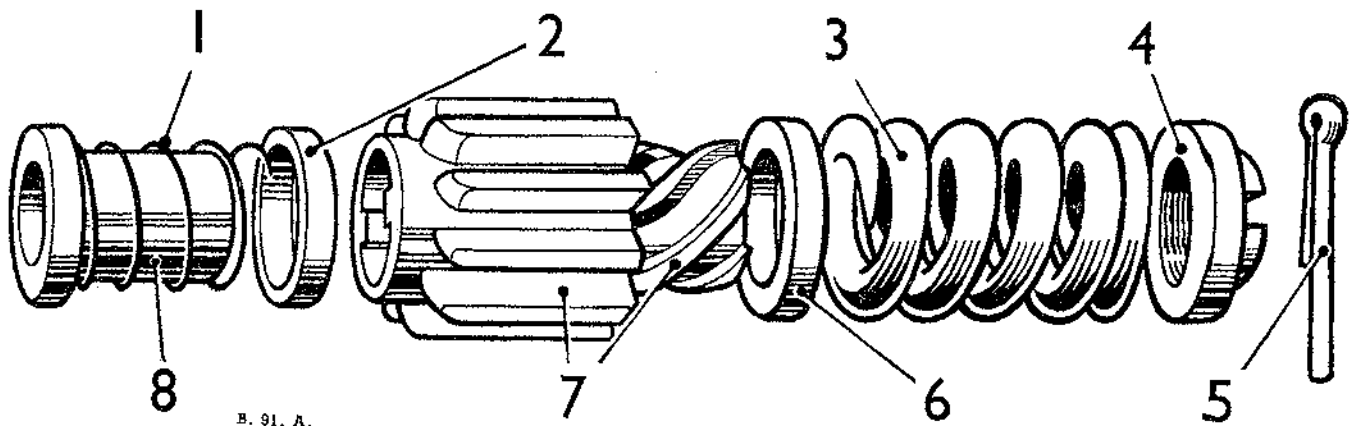

B. 91. A.

Fig. N.11. The starter pinion assembly.

- |                        |                 |               |                               |
|------------------------|-----------------|---------------|-------------------------------|
| 1. Restraining spring. | 3. Main spring. | 5. Split pin. | 7. Screwed sleeve and pinion. |
| 2. Collar.             | 4. Shaft nut.   | 6. Washer.    | 8. Restraining spring sleeve. |

If this is ineffective, carefully polish with a strip of fine glass-paper, while rotating the armature. To remedy a badly worn commutator, dismantle the starter drive as described above and remove the armature from the end bracket. Now mount the armature in a lathe, rotate it at a high speed and take a light cut with a very sharp tool. Do not remove any more metal than is absolutely necessary, and finally polish with very fine glass-paper.

The mica on the starter commutator **must not be undercut**.

### Field Coils

The field coils can be tested for an open circuit by connecting a 12-volt battery, having a 12-volt bulb in one of the leads, to the tapping point of the field coils to which the brushes are connected and the field terminal post. If the lamp does not light, there is an open circuit in the wiring of the field coils.

Lighting of the lamp does not necessarily mean that the field coils are in order, as it is possible that one of them may be earthed to a pole shoe or to the yoke. This may be checked by removing the lead from the brush connector and holding it on a clean part of the starter yoke. Should the bulb now light it indicates that the field coils are earthed.

Should the above tests indicate that the fault lies in the field coils, they must be renewed. When renewing field coils carry out the procedure detailed in the Generator Section.

### Armature

Examination of the armature will in many cases reveal the cause of failure, e.g. conductors lifted from the commutator due to the starter being engaged while the engine is running and causing the armature to be rotated at an excessive speed. A damaged armature

must in all cases be renewed—no attempt should be made to machine the armature core or to true a distorted armature shaft.

### Bearings (Commutator End)

Bearings which are worn to such an extent that they will allow excessive sideplay of the armature shaft must be renewed. To renew the bearing bush, proceed as follows :—

Press the new bearing bush into the end bracket, using a shouldered mandrel of the same diameter as the shaft which is to fit in the bearing.

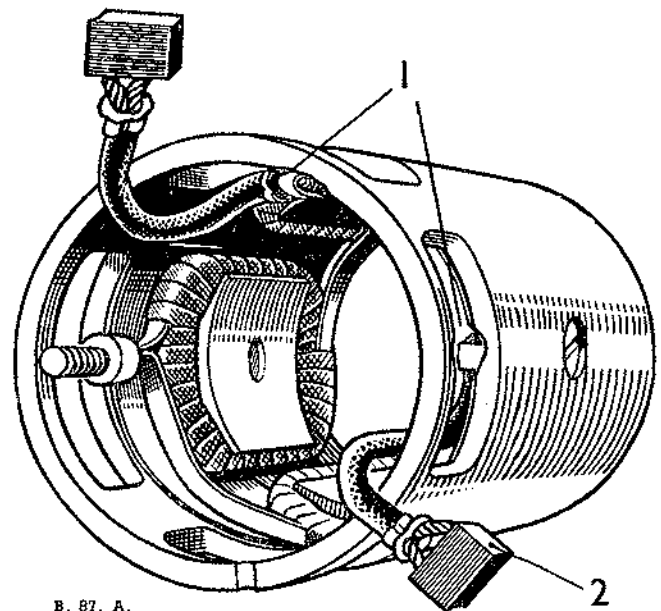

B. 87. A.

Fig. N.12. Starter yoke.

- |             |                           |
|-------------|---------------------------|
| 1. Brushes. | 2. Tapping on field coil. |
|-------------|---------------------------|



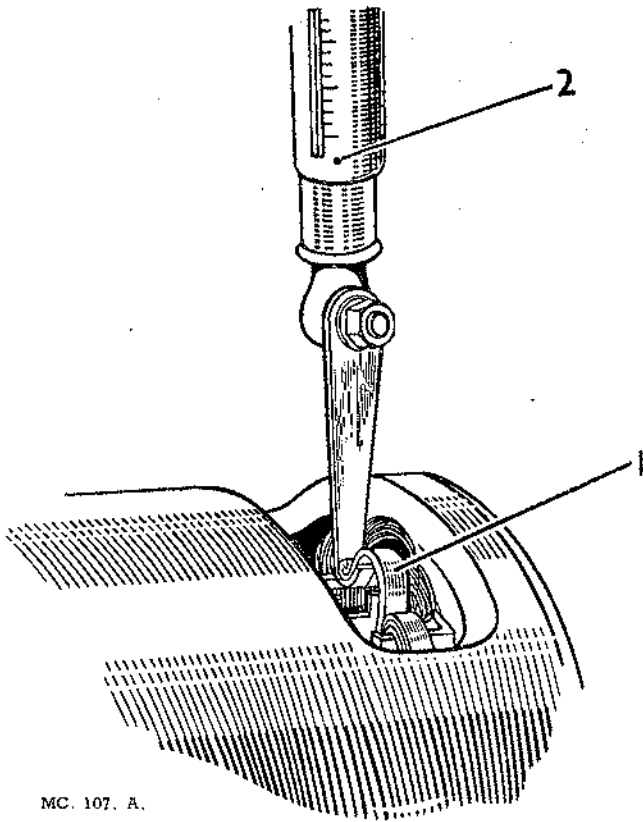

MC. 107. A.

Fig. N.13. Checking brush spring tension.  
1. Brush spring. 2. Spring scale.

**Note.**—The bearing bush is of the porous phosphor-bronze type, and before fitting, new bushes should be allowed to stand completely immersed for twenty-four hours in thin engine oil in order to fill the pores of the bush with lubricant.

**Reassembly**

The reassembly of the starter is a reversal of the operations described in this section.

**Note.**—When reassembling the starter drive the locating nut must be re-caulked to the armature shaft.

**Section N.13**

**CONTROL BOX**

This unit contains the cut-out and voltage regulator. The regulator controls the generator output in accordance with the load on the battery and its state of charge. When the battery is discharged, the generator gives a high output so that the battery receives a quick recharge, which brings it back to its normal state in the minimum time.

On the other hand, if the battery is fully charged the generator will give a trickle charge only, which is sufficient to keep the battery in good condition without over charging, thus avoiding damage to the plates.

The regulator also causes the generator to give a controlled boosting charge immediately after starting up, which quickly restores to the battery the energy taken from it when starting. After about 30 minutes running, the output of the generator falls to a steady rate, best suited to the particular state of charge of the battery.

The cut-out is an automatic switch for connecting and disconnecting the battery with the generator. This is necessary because the battery would otherwise discharge through the generator with the engine stopped or running at low speed.

**Regulator Adjustment**

The regulator is carefully set during manufacture, and in general it should not be necessary to make any further adjustment. If however, the battery does not keep in a charged condition, or if the generator output does not fall when the battery is fully charged, the setting should be checked, and if necessary corrected.

It is important, before altering the regulator setting when the battery is in a low state of charge, to check that its condition is not due to a battery defect or to slipping of the generator belt.

**Checking and Adjusting the Electrical Setting**

The electrical setting can be checked without removing the cover from the control box.

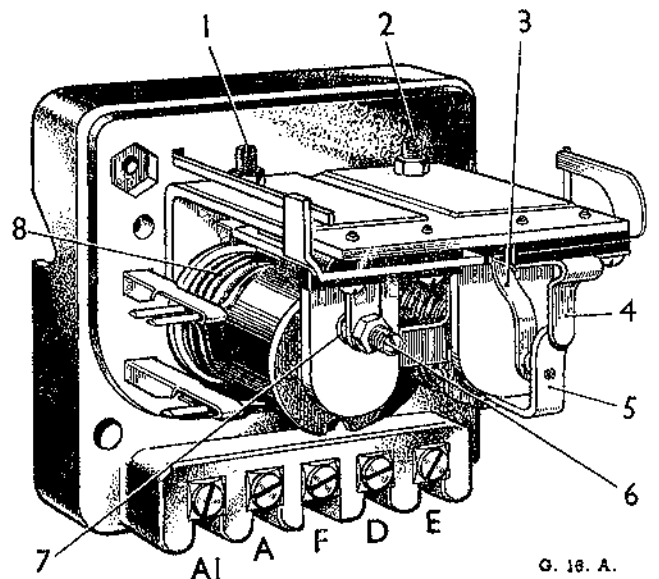

G. 18. A.

Fig. N.14. Control box.  
1. Regulator adjusting screw. 5. Armature tongue and moving contact.  
2. Cut-out adjusting screw. 6. Regulator moving contact.  
3. Fixed contact blade. 7. Fixed contact.  
4. Stop arm. 8. Regulator series windings.

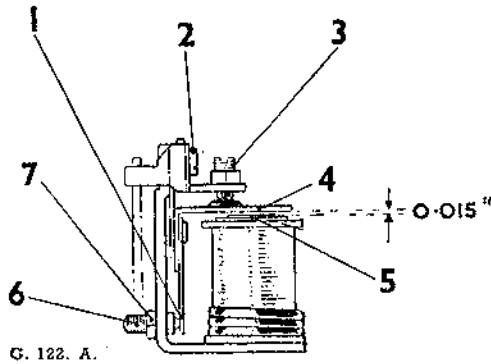

Fig. N.15. Regulator mechanical setting.

- |                                    |                             |
|------------------------------------|-----------------------------|
| 1. Armature tension spring.        | 4. Armature.                |
| 2. Armature securing screws.       | 5. Core face and shim.      |
| 3. Fixed contact adjustment screw. | 6. Voltage adjusting screw. |
|                                    | 7. Lock nut.                |

- (1) Withdraw the cables from the terminals marked "A" and "A.1" at the control box and join them together. Connect the negative lead of a moving coil (0 to 20 volts) voltmeter, to control box terminal "D" and connect the other lead to terminal "E".
- (2) Slowly increase the speed of the engine until the voltmeter needle "flicks" and then steadies. This should occur at a voltmeter reading between the limits given for the appropriate temperature of the regulator. If the voltage at which the reading becomes steady is outside these limits the regulator must be adjusted.
- (3) Shut off the engine and remove the control box cover. Release the locknut securing the regulator adjusting screw and turn the adjusting screw in a clockwise direction to raise the setting, or in an anti-clockwise direction to lower the setting. Turn the screw a fraction at a time and tighten the locknut. Repeat this procedure until the desired setting is obtained.
- (4) Adjustment of the regulator open circuit should be completed within 30 seconds otherwise overheating of the shunt winding will cause false settings to be made. A generator run at high speed on open circuit will build up a high voltage, therefore when adjusting the regulator do not run the engine up to more than half throttle or a false setting will be made. Remake the original connections.

### Mechanical Setting

The mechanical settings of the regulator, shown in Fig. N.15 are accurately adjusted before leaving the factory, and provided that the armature carrying the moving contact is not removed, these settings should

not be tampered with. If however, the armature has been removed, the regulator will have to be reset. To do this, proceed as follows :—

- (1) Slacken the fixed contact locking nut (3), and unscrew the contact until it is well clear of the armature moving contact. Slacken the voltage adjusting screw locking nut (7) and unscrew the adjuster until it is well clear of the armature tension spring. Slacken the two armature assembly securing screws (2).
- (2) Insert a .015 in. feeler gauge (which should be wide enough to completely cover the core face), between the armature and the core shim. Take care not to turn up, or damage the edge of the shim. Press the armature squarely down against the gauge and re-tighten the two armature securing screws.
- (3) With the gauge still in position, screw the adjustable contact down until it just touches the armature contact. Tighten the locking nut and remove the feeler gauge. Reset the voltage adjusting screw as described under "Electrical Setting".

### Cleaning Regulator Contacts

After periods of long service it may be found necessary to clean the regulator contacts. Fine carborundum stone or fine emery cloth may be used. Carefully wipe away all traces of dust or other foreign matter, using a clean fluffless cloth moistened with methylated spirits.

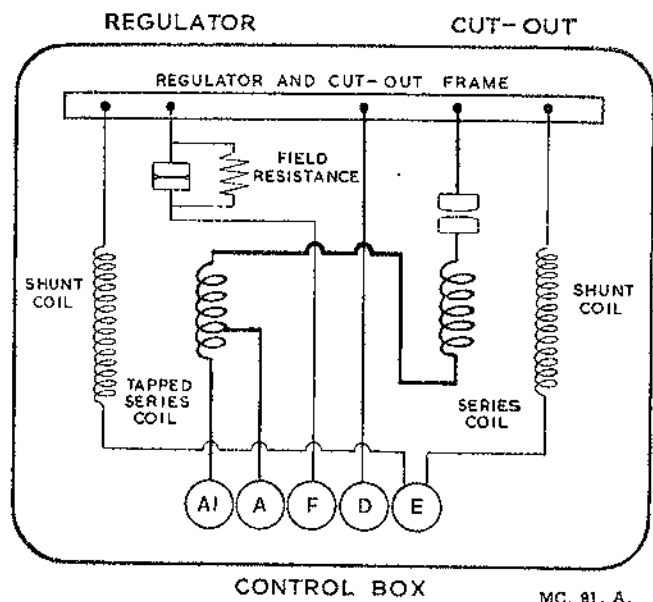

Fig. N.16. Internal connections of the control box.

### Cut-Out Electrical Setting

If the regulator is correctly set but the battery is still not being charged the cut-out may be out of adjustment. To check the voltage at which the cut-out operates remove the control box cover and connect the voltmeter between the terminals "D" and "E". Start the engine and slowly increase its speed until the cut-out contacts are seen to close, noting the voltage at which this occurs. This should be 12.7 to 13.3 volts.

If operation of the cut-out takes place outside these limits, it will be necessary to adjust. To do this :—

- (1) Slacken the locknut of (2) Fig. N.14, securing the cut-out adjusting screw and turn the screw in a clockwise direction to raise the voltage setting, or in an anti-clockwise direction to reduce the setting. Turn the screw a fraction at a time and then tighten the locknut.

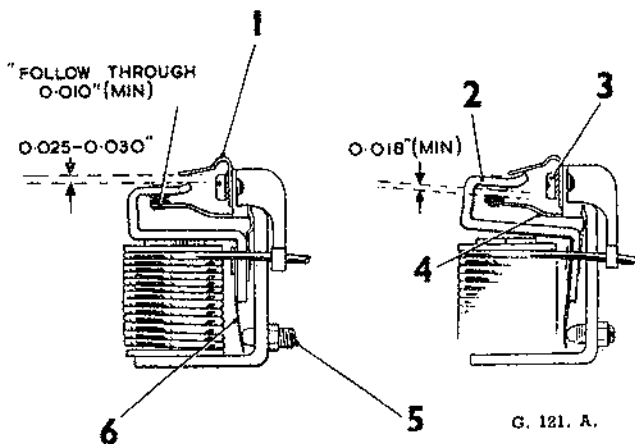

Fig. N.17. Cut-out mechanical setting.

- |  |                             |
|--|-----------------------------|
| 1. Stop arm.                           | 3. Armature securing screw. |
| 2. Armature tongue and moving contact. | 4. Fixed contact blade.     |
|  | 5. Cut-out adjusting screw. |
|  | 6. Armature tension spring. |

- (2) Test after each adjustment by increasing the engine speed and noting the voltmeter readings at the instant of contact closure. Electrical settings of the cut-out, like the regulator, must be made as quickly as possible because of temperature rise effects. Tighten the locknut after making the adjustment.
- (3) Adjustment of the drop-off voltage (8.5 to 11 volts) is effected by carefully bending the fixed contact blade. If the cut-out does not operate there may be an open circuit in the wiring of the cut-out and regulator unit, in which case the unit should be removed for examination or renewal.

### Cut-out Mechanical Setting

If for any reason the cut-out armature has to be removed from the frame, care must be taken to obtain

the correct air gap settings on reassembly. These can be obtained as follows :—

- (1) Slacken the adjusting screw locking nut Fig. N.17, and unscrew the adjusting screw (5) until it is well clear of the armature tension spring (6). Slacken the two armature assembly securing screws (3).
- (2) Press the armature squarely down against the copper sprayed core face and re-tighten the two armature assembly securing screws.
- (3) Using a pair of round-nosed pliers, adjust the gap between the armature stop-arm and the armature tongue by bending the stop-arm. The gap must be .025 in. to .030 in. when the armature is pressed squarely down on the core face.
- (4) Similarly, the insulated contact blade must be bent so that, when the armature is pressed squarely down against the core face, there is a minimum "follow through", or contact deflection of .010 in. The contact gap, when the armature is in the free position must be .018 in. minimum. Reset the cut-out adjusting screw as described under "Cut-out Electrical Setting".

### Cleaning Cut-out Contacts

If the contacts appear rough or burnt, place a strip of fine glass paper between, and with them closed by hand, draw the paper through. This should be done two or three times with the rough side towards each contact. Wipe away all dust or other foreign matter, using a clean fluffless cloth moistened with methylated spirits.

Do not use emery cloth or carborundum stone for cleaning the cut-out contacts.

## Section N.14

### FUSE UNIT

#### Description

The fuse unit, which is mounted on the bulkhead under the engine cowl, is an open insulated moulding carrying two single-pole 35-amp. cartridge-type fuses which are held by spring clips between grub-screw-type terminal blocks. Two spare fuses are carried in recesses in the fuse unit base and are positioned by a common retaining spring. The fuse which bridges the terminal blocks (A1—A2) is to protect general auxiliary circuits, e.g. the horn and interior lamps, which are independent of the ignition switch. The other fuse, bridging terminal blocks (A3—A4), is to protect ignition auxiliary circuits, e.g. the fuel gauge, windscreen wiper motor and flashing indicators, which only operate when the ignition is switched on.

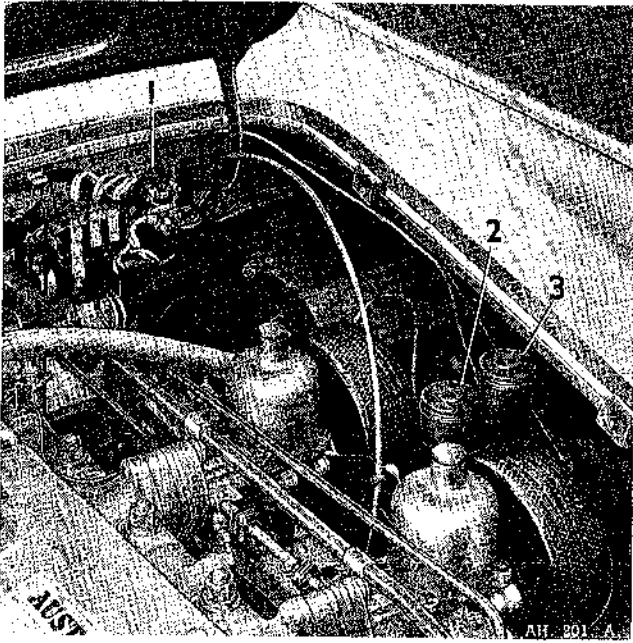

Fig. N.18. Location of fuse unit.

1. Fuse unit. 2. Brake fluid reservoir. 3. Clutch fluid reservoir.

### To Remove

- (1) Disconnect the cables from the battery.
- (2) Remove the two nuts securing the fuse unit to the bulkhead.
- (3) Slacken the terminal grub screws and withdraw the cables to release the fuse unit.

### To Replace

- (1) Ensure all fuses are serviceable.
- (2) Reconnect the cables to the appropriate terminals on the fuse unit in accordance with the colour code given in the wiring diagram.
- (3) Secure the fuse unit to the bulkhead.
- (4) Reconnect the battery cables and test the circuits concerned.

## Section N.15

### THE FLASHER UNIT

#### Description

The Lucas flasher unit is situated in the engine compartment and is operated by a self-cancelling steering column direction switch, a warning lamp being provided in the centre of the fascia panel.

The unit is contained in a small cylindrical metal container, one end of which is rolled over on to an insulated plate carrying the mechanism and three terminals. The unit depends for its operation on the linear expansion of a length of wire which becomes

N.14

heated by an electric current flowing through it. This actuating wire controls the movement of a spring-loaded armature attached to a central steel core and carrying a moving contact—the sequence of operation being as follows :—

When the direction-indicator switch is turned either to left or right, current flows through the actuating wire, ballast resistor and a coil wound on the central core and thence to earth via the flasher lamp filaments. This current is limited by the ballast resistor to a value which will ensure that the flasher lamp filaments do not light at this stage. The actuating wire grows in length under the heating influence of the current and allows the armature to move inwards to its alternative position, thereby closing a pair of contacts in the supply circuit to the flasher lamps and, at the same time, short-circuiting the actuating wire. The increased electro-magnetic attraction of the armature to the core, due to the full lamp current now flowing through the coil, serves to hold the closed contacts firmly together. At the same time a secondary spring-loaded armature is attracted to the core and closes a pilot warning lamp circuit so that now both flasher lamps and warning lamp are illuminated.

Since, however, heating current no longer flows through the short-circuited wire, the latter cools down and consequently contracts in length. The main armature is therefore pulled away from the core, the contacts opened and the light signals extinguished. The consequent reduction of electro-magnetism in the core allows the secondary armature to return to its

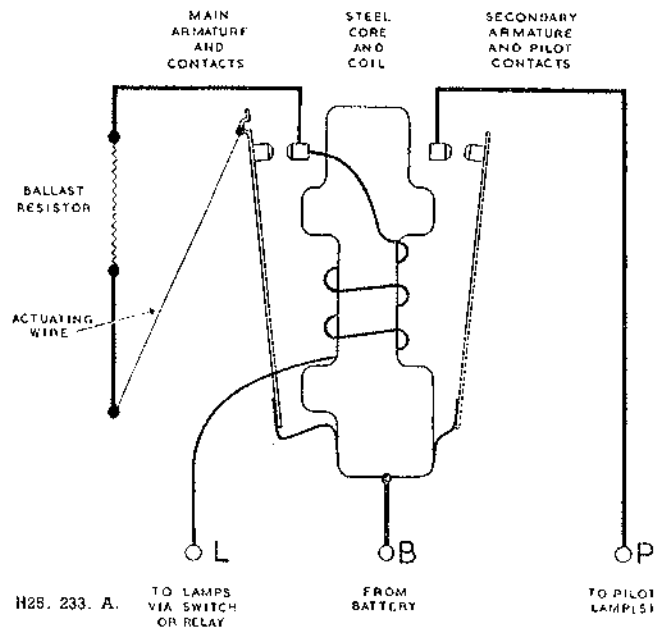

Fig. N.19. Symbolic representation of flasher unit model FL5.

original position and so extinguish the pilot warning light. The above sequence of operations continues to be repeated until the indicator switch is returned to the off position. A symbolic representation of the flasher unit is shown in Fig. N.19.

### Functions of Warning Lamp

The warning lamp not only serves to indicate that the flasher unit is functioning correctly but also gives warning of any bulb failure occurring in the external direction-indicator lamps—since a reduction in bulb current flowing through the coil reduces the electro-magnetic effect acting on the secondary armature and so prevents closure of the pilot light contacts.

### The Brake Switch Overriding Relay

When stop-light filaments are used also as direction lights, it is essential that responses to the flasher unit should override simultaneous applications of the brake switch. In the event of simultaneous applications being made, the relay shown in Fig. N.20 allows the appropriate stop-light filament to flash and the other to remain steadily illuminated as long as the brake pedal is depressed.

Operation of the direction-indicator switch to right or left first energises the appropriate relay operating coil which effects movement of its associated armature in the direction shown by the arrow (Fig. N.20 inset). By this means, flasher unit terminal 'L' is connected to relay terminals '2' and '3' (or '6' and '7') and, thus, to the indicating lamps. As long as the relay coil remains energised, connection to the brake switch on the corresponding side is interrupted.

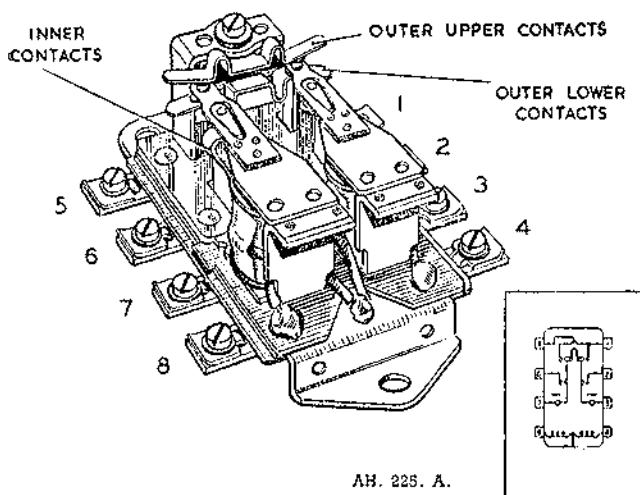

Fig. N.20. Brake switch overriding relay, model DB10, with cover removed and (inset) internal connections.

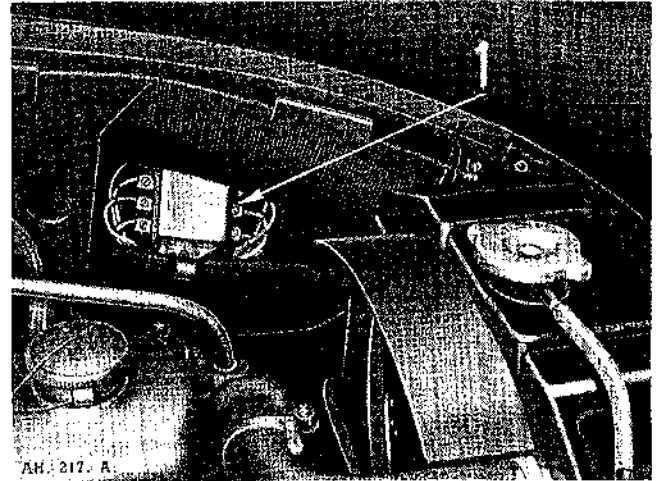

Fig. N.21. The location of the brake switch overriding relay.

### Checking Faulty Operation

In the event of trouble occurring with a flashing light direction-indicator system, the following procedure should be followed :—

- (1) Check the bulbs for broken filaments.
- (2) Refer to the vehicle wiring diagram and check all flasher circuit connections.
- (3) Switch on the ignition.
- (4) Check with a voltmeter that flasher unit terminal 'B' is a battery voltage with respect to earth.
- (5) Connect together flasher unit terminals 'B' (or 'X') and 'L' and operate the direction-indicator switch. If the flasher lamps now light, the flasher unit is defective and must be replaced.
- (6) If the lamps do not light in test (5), check the brake switch overriding relay as follows :—
  - (a) Temporarily link relay terminal '1' to terminals '2' and '3'.  
The left-hand lamps should now flash.
  - (b) Temporarily link relay terminal '1' to terminals '6' and '7'.  
The right-hand lamps should now flash.
  - (c) If the lamps do flash in test (6), the relay is defective and requires either re-setting, see "Checking and Re-setting Air Gaps".
  - (d) Direction-indicator switches are best checked by substitution.

### Maintenance

Flasher units cannot be dismantled for subsequent reassembly. A defective unit must therefore be replaced, care being taken to reconnect as the original.

The cover of the brake switch overriding relays can be withdrawn for checking air-gap settings. No further dismantling is possible. In the event of defective coils or contacts occurring, relays must be replaced as

complete units, care being taken to reconnect as the original.

Similarly, defective direction-indicator switches are normally replaceable only as complete units.

#### Replacement of Flasher Unit

When replacing a flasher unit or installing a flashing light system, it is advisable to test the circuits before connections to flasher terminals 'L', 'B' and 'P' are made. When testing, join the cables normally connected to these terminals together and operate the direction-indicator switch. In the event of a wrong connection having been made, the ignition auxiliaries fuse will blow but no damage will be done to the flasher unit.

Flasher units must be handled with care. Factory-made settings, though good for conditions of normal automobile duty, can be thrown off balance by rough handling.

#### Checking and Re-setting Relay Air-Gaps

Prise off the relay cover, noting the non-reversible locating slot between terminals '6' and '7'.

Each armature controls three pairs of contacts, two pairs being normally open and one pair normally closed. For setting purposes three contacts can be identified as follows :

- Inner pairs, adjacent to bobbins, normally open.
- Outer lower pairs, normally open.
- Outer upper pairs, normally closed.

When an inner pair of contacts is just touching, a relay in correct adjustment will have an armature-to-bobbin core gap of 0.010" to 0.015". In addition, when these contacts are separated by a 0.007" to 0.013" gap, the outer lower contacts must be separated by 0.012" to 0.018" gap. If the gaps are not within these limits, the relay must be re-set.

Adjustments are made by bending the fixed contact carriers with a suitably slotted bending tool. Setting is effected in three stages, as follows :—

- (1) Insert a 0.010" gauge between one of the armatures and its bobbin core.
- (2) Press down the armature.
- (3) Adjust the height of the inner contact carrier until the inner pair of contacts is just touching.
- (4) Remove the gauge.
- (5) Insert the 0.010" gauge between the inner pair of contacts and lightly press down the armature.
- (6) Adjust the outer lower contact carrier until the outer lower contacts are just touching.
- (7) Remove the gauge.
- (8) With the outer lower contacts just touching, adjust the upper contact carrier until a 0.015" gauge is a sliding fit between the outer upper contacts.
- (9) Remove the gauge and refit the cover.

N.16

## Section N.16

### WINDSCREEN WIPERS

#### Maintenance

- (1) An inspection should be made of the rubber wiping elements which after long service become worn and should be renewed.
- (2) The rubber grommet or washer around the wheel-box spindle should be lubricated with a few drops of glycerine.
- (3) Methylated spirits (de-natured alcohol) should be used to remove oil, tar spots and other stains from the windscreen. It has been found that the use of some silicone and wax-based polishes for this purpose can be detrimental to the rubber wiping elements.
- (4) The gearbox and cable rack are packed with grease during manufacture and need no further lubrication.

#### Checking Switching Mechanism

If the wiper fails to park or parks unsatisfactorily, the limit switch in the gearbox cover should be checked. Unless the limit switch is correctly set, it is possible for the wiper motor to overrun the open circuit position and continue to draw current.

#### Resetting the Limit Switch

Slacken the four screws securing the gearbox cover and observe the projection near the rim of the limit switch. Position the projection in line with the groove

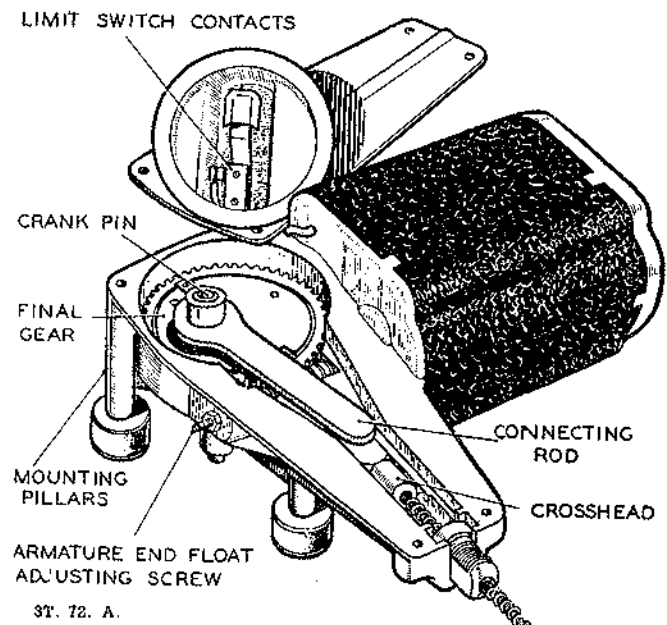
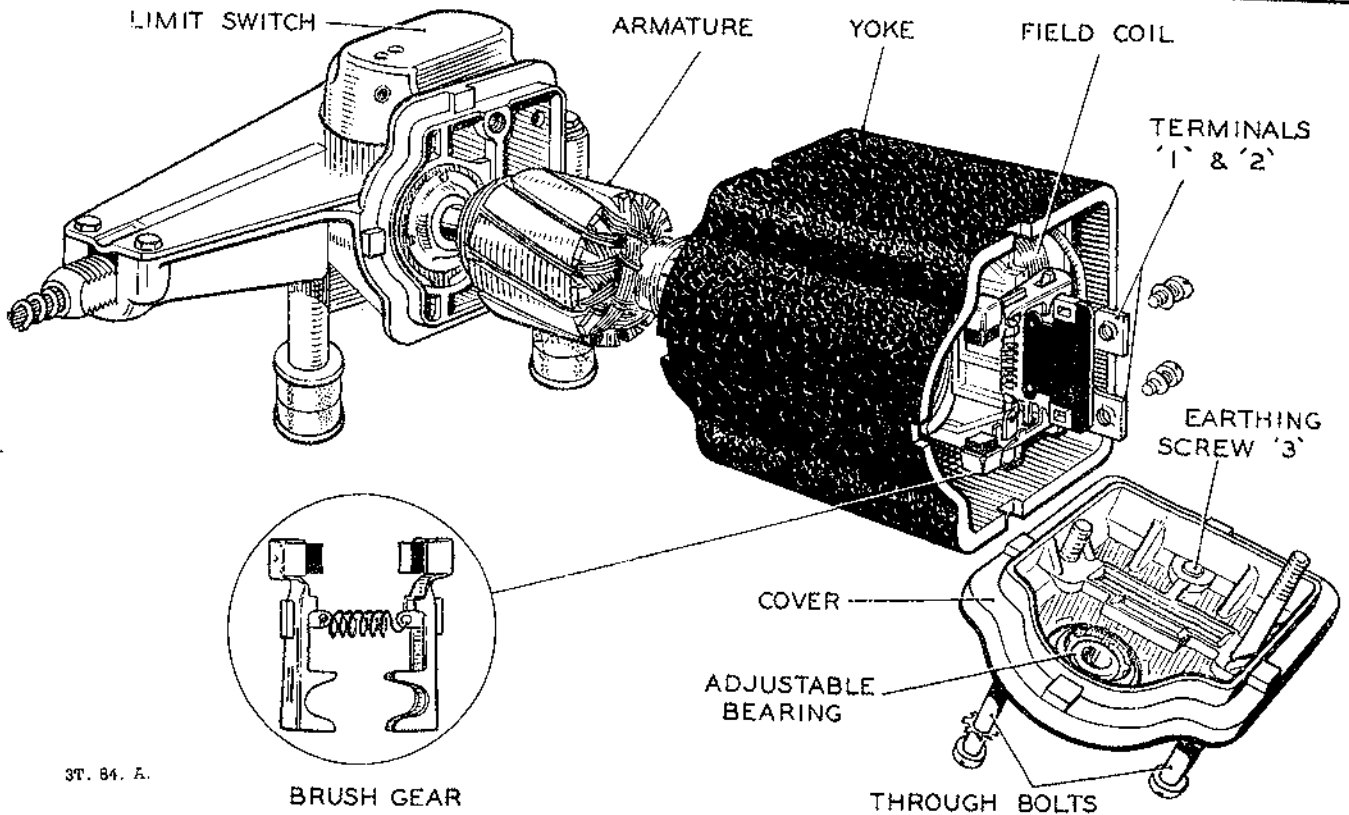

Fig. N.22. Wiper motor gearbox cover removed (Model D.R.2)



3T. 84. A.

Fig. N.23. Wiper motor exploded.

in the gearbox cover. Turn the limit switch 25° in an anti-clockwise direction and tighten the four securing screws. If the wiping blades are required to park on the opposite side of the screen, the limit switch should be turned back 180° in a clockwise direction.

### Checking Current Consumption

If the wiper fails to operate, or operates unsatisfactorily, switch on the wiper and note the current being supplied to the motor. The normal running current should be 2.3 to 3.1 amps. Use a 0 to 15 amp. moving coil ammeter connected in the wiper circuit, then proceed as follows :—

### Wiper takes no Current

Examine the fuse protecting the wiper circuit. If the fuse has "blown", examine the wiring of the motor circuit and of all other circuits protected by that fuse. Replace any cables which are badly worn or chafed, if necessary fitting protective sleeving over the cables to prevent a recurrence of the fault.

If the external wiring is found to be in order, replace the fuse with one of the recommended size. Then proceed as for the wiper taking an abnormally high current.

If the fuse is intact, examine the wiring of the motor circuit for breaks and ensure that the wiper control switch is operating correctly.

When a current-operated thermostat is fitted, test it by connecting an ohmmeter across its terminals in place of the two cables. If a closed circuit is indicated, the thermostat is in order, and the cables must be refitted. An open circuit means that the thermostat has operated but not reset. Check the thermostat by substitution. Adjustment of the thermostat must not be attempted.

If the thermostat is in order, proceed as for the wiper taking an abnormally high current.

### Wiper takes Abnormally Low Current

Check that the battery is fully charged. The performance of the motor is dependent on the condition of the battery.

Remove the commutator end bracket and examine the brush gear, ensuring that it bears firmly on the commutator. The tension spring must be renewed if the brushes do not bear firmly on the commutator. Brush levers must move freely on the pivots. If these levers are stiff they should be freed by working them backwards and forwards by hand.

Examine the commutator and, if necessary, clean with a petrol-moistened cloth. A suspected armature should be checked by substitution.

#### Wiper takes Abnormally High Current

If an abnormally high current is shown on the ammeter, this may be due to excessive load on the driving shaft. The stall current of the motor cold is 14 amp., and hot is 8 amp.

If there is no obvious reason for this, such as a sticking wiper blade, a check should be made at the gearbox.

Remove the gearbox cover and examine the gear assembly, checking that a blow on the gearbox end bracket has not reduced the armature end float. The armature end float adjusting screw must be set to give an armature end play of 0.008 in. (.20 mm.) to 0.012 in. (.30 mm.).

Sluggish operation with excessive current consumption may be caused through frictional losses in badly positioned or defective connecting tubes. The connecting tubes can be checked, using a cable gauge. (Details of this gauge can be obtained from any Lucas Agent). The gauge cable is similar in appearance to the driving rack but is 0.010 in. (.26 mm.) larger in diameter and is less flexible. The gauge will not easily pass through connecting tubes having less than the minimum permissible curvature.

To check the tubing using the gauge, it is necessary to remove the inner rack. Insert the gauge into the connecting tube as far as the first wheelbox and then withdraw it. Remove the tubing connecting the wheelboxes. Insert and withdraw the gauge. If the gauge moves freely, the tubing is correctly installed. If the gauge does not move freely, the tubing must be checked for sharp bends and obstructions. Check the wheelboxes for alignment and then re-assemble.

Pieces of carbon short-circuiting adjacent segments of the commutator will also cause excessive current consumption. The resistance between adjacent commutator segments should be 0.34 to 0.41 ohms. Cleaning the commutator and brushgear removes this fault. When dismantling, check the internal wiring of the motor for evidence of short-circuiting due to chafed or charred insulation. Slip a new piece of sleeving over any charred connections, and arrange them so that they do not rub against sharp edges.

While the motor is dismantled check the value of the field resistance. If it is found to be much lower than 12.8 to 14 ohms, a short-circuit in the windings is indicated and a new field coil must be fitted. Other evidence of a short circuit will be given by charred leads from the field coil.

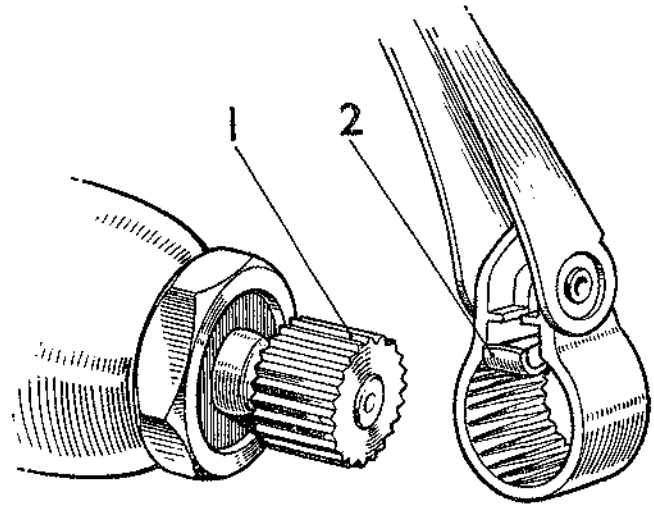

G. 17. A.

Fig. N.24. Windscreens wiper arm assembly.  
1. Splined driving drum. 2. Retaining clip.

#### To Remove the Rack and Motor Unit.

Release the wiping arms from the spindles, see Fig. N.24, disconnect the union on the Bundy tube at the gearbox, and remove the nuts from the motor mounting bolts. Withdraw the motor and cable rack clear of the Bundy tube.

#### To Dismantle the Motor

- (1) Withdraw the four screws securing the gearbox cover and remove the cover.
- (2) Withdraw the terminal screws and the through bolts at the commutator end bracket.
- (3) Remove the commutator end bracket clear of the yoke.
- (4) The brush gear can be removed by lifting it clear of the commutator and withdrawing it as a unit. Care should be taken at this point to note the particular side occupied by each brush so that each may be replaced in its original setting on the commutator.
- (5) Access to armature and field coils can be gained by withdrawing the yoke.
- (6) If it is necessary to remove the field coil, unscrew the two screws securing the pole piece to the yoke. These screws should be marked so that they can be replaced in their original holes.
- (7) Press out the pole pieces complete with field coil, marking the pole piece so that it can be replaced in its correct position inside the yoke. The pole piece can now be pressed out of the field coil.

#### To Dismantle the Gearbox Unit

Remove the circlip and washer from the crosshead connecting link pin and lift off the crosshead and cable



rack assembly. Then remove the circlip and washer from the final gear shaft located underneath the gearbox unit. Remove any burr from the circlip groove before lifting out the final gear. The armature and worm drive can now be withdrawn from the gearbox. All gear teeth should be examined for signs of damage or wear and, if necessary, new gears fitted.

#### Reassembly

Reassembly is a reversal of the above procedures. When reassembling, the following components should be lubricated, using the lubricants recommended :—

- (1) **Armature bearings.** These should be lubricated with S.A.E.20 engine oil—the self-aligning bearing being immersed in this for 24 hours before assembly.
- (2) **Armature shaft (commutator end).** Apply S.A.E.20 engine oil sparingly.
- (3) **Felt lubricator in gearbox.** Apply S.A.E.20 engine oil carefully.
- (4) **Worm wheel bearings, crosshead, guide channel, connecting rod, crank pin, eccentric coupling assembly, worm and final gear shaft.** Grease liberally as for front hubs.
- (5) **Cable rack and wheelboxes.** Grease liberally as for front hubs.

#### Testing

Switch on the ignition and the wiper control. The two wiper areas should be approximately symmetrical on the windscreen.

#### Fitting a Blade to a Wiper Arm

Pull the wiper arm away from the windscreen and insert the curved “wrist” of the arm into slotted spring fastening of the blade. Swivel the two components into engagement.

#### Fitting a Wiper Arm to Driving Spindle

- (1) First ensure that the wiper spindles are in the correct parking position by switching on the ignition and turning the wiper control on and then off.
- (2) To fit the arms, press the headpieces on to the spindles at the correct parking angle until the retaining clip is heard to snap over the end of the spindle drum.
- (3) Switch off the wiper control. The arms should come to rest in the correct parking position.

#### Adjusting

Correct operation can be obtained by adjusting the position of the arms relative to the spindles. If necessary the position of the arms may be adjusted by removing

and re-engaging them with the splined driving spindles, the angular pitch of the splines being 5°.

Do not attempt to turn the arms whilst in position, but press back the retaining clip (Fig. N.24) in the headpieces and withdraw the arms from the driving spindles. Refit in the desired position. The above adjustment may affect the self-parking position. If so, it may be corrected by adjustment of the limit switch position, as described above.

If the arms and blades are required to come to rest on the opposite side, the limit switch should be turned through 180°. It should be noted that the switch cover is designed for turning through a sector only and not through 360°. This feature prevents unnecessary twisting of the external flexible connections.

## Section N.17

### IGNITION SWITCH

#### Description

The ignition switch is a rotary barrel-type Yale lock located centrally on the facia panel. Operation of the switch is carried out by inserting the ignition key into the lock and turning it in a clockwise direction. In addition to controlling the primary circuit of the ignition coil the switch also operates as a master switch for the ignition, fuel gauge and pump, and the flashing indicators.

#### To Test in the Vehicle

Test the ignition switch in the manner described in Section B.

#### To Remove

- (1) Unscrew the locknut securing the switch to the instrument panel and release the electrical connections at the rear of the switch.
- (2) Remove the switch from the instrument panel.

## Section N.18

### DIRECTION INDICATOR WARNING LAMP

#### To Remove and Dismantle

- (1) Pull out the bulb holder with bulb from the rear of the warning lamp.
- (2) Unscrew the bulb.
- (3) To release the green lens unscrew the chrome retaining ring situated on the front of the facia panel.

#### To Reassemble and Install

The reassembly and installation is the reversal of the procedure “To Remove and Dismantle”.

## ELECTRICAL SYSTEM

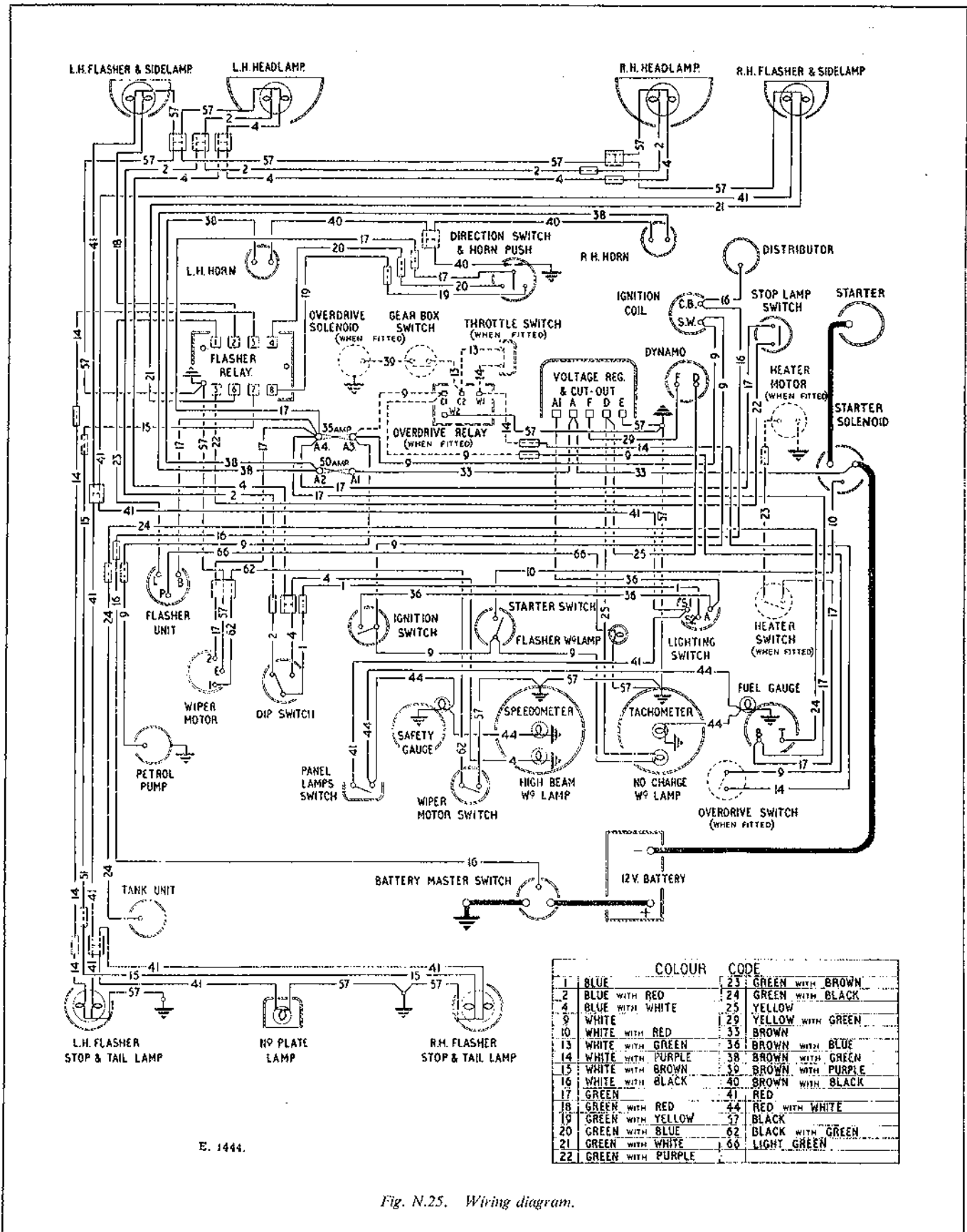

Fig. N.25. Wiring diagram.

## Section N.19

### PANEL LIGHT BULBS

#### To Remove

- (1) Pull out the bulb holder with bulb from the rear of the warning lamp.
- (2) Unscrew the bulb.

#### To Replace

The replacement of a panel light bulb is a reversal of the removal procedure.

## Section N.20

### HEADLAMP MAIN BEAM WARNING LIGHT BULB

For details see Section N.19.

## Section N.21

### IGNITION WARNING LIGHT BULB

For details see Section N.19.

## Section N.22

### FUEL GAUGE

#### To Remove

- (1) Release the "T" and "B" terminals from behind the gauge.
- (2) Unscrew the centrally placed knurled securing nut.
- (3) Withdraw the gauge forwards of the instrument panel.

#### To Replace

The replacement is the reversal of the procedure "To Remove", noting the following point :—

- (1) Connect the cables in accordance with the colour code given in the wiring diagram.

## Section N.23

### OVERDRIVE SWITCH

#### To Remove

- (1) Unscrew the locknut securing the switch to the instrument panel.
- (2) Withdraw the switch from its locating hole in the panel.
- (3) Disconnect the cables from the instrument panel.

#### To Replace

The replacement of the overdrive switch is a reversal of the procedure "To Remove". Reconnect the cables in accordance with the colour code in the wiring diagram.

## Section N.24

### PANEL LAMPS SWITCH

#### To remove

- (1) Unscrew the two screws securing the panel

lamps switch to the underside of the instrument panel.

- (2) Disconnect the cables from the switch terminals.
- (3) Withdraw the switch from the instrument panel.

#### To Replace

The replacement of the panel lamps switch is a reversal of the procedure "To Remove". Reconnect the cables in accordance with the colour code given in the wiring diagram.

## Section N.25

### WINDSCREEN WIPER SWITCH

#### To Remove

- (1) Disconnect the switch knob from the switch by pushing in the retaining plunger and pulling the knob away from the instrument panel.
- (2) Unscrew the nut on the outside of the switch body.
- (3) Disconnect the cables from the switch terminals.
- (4) Withdraw the switch from the instrument panel.

#### To Install

The installation of the windscreen wiper switch is a reversal of the procedure "To Remove". Reconnect the cables in accordance with the colour code given in the wiring diagram.

## Section N.26

### LIGHTING SWITCH

The removal and installation of this switch is the same as that described for the windscreen wiper switch.

## Section N.27

### HEADLIGHT BULBS

#### To Remove

- (1) Unscrew the screw securing the front rim and remove the rim from the headlight unit.
- (2) Remove the dust-excluding cover to expose the three spring loaded adjustment screws.
- (3) Press the light unit inwards against the tension of the adjusting screw springs and turn it in an anti-clockwise direction until the heads of the screws can be disengaged through the slotted holes in the light unit rim.

**Note.**—Do not disturb the screws as this will alter the lamp setting.

- (4) Twist the adaptor in an anti-clockwise direction and pull it off.
- (5) Remove the bulb.

#### To Replace

- (1) Install the replacement bulb in the holder, taking care to locate it correctly.

- (2) Engage the projections on the inside of the adaptor with the slots in the holder, press on and secure by twisting in a clockwise direction.
- (3) Position the light unit so that the heads of the adjustment screws protrude through the slotted holes in the flange, press the unit in and turn in a clockwise direction.
- (4) Replace the dust-excluding cover and refit the front rim.

### Section N.28

#### HEADLAMP BEAM SETTING

The lamps should be set so that the main driving beams are straight ahead and parallel to one another, and parallel to the road surface. If adjustment to the setting is required, first remove the front rim and rubber as previously described. Set each lamp to the correct position in the vertical plane by means of the vertical adjustment screw at the top of the reflector unit. Turn the screw in a clockwise direction to raise the beam and in an anti-clockwise direction to lower it. Horizontal adjustment can be altered by turning the adjustment screws on each side of the light unit.

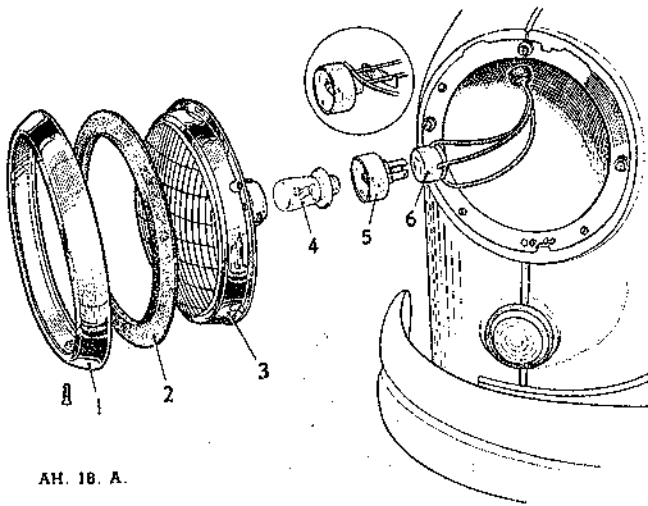

Fig. N.26. Headlamp exploded.

- |                 |                         |                         |
|-----------------|-------------------------|-------------------------|
| 1. Front rim.   | 3. Glass and reflector. | 5. Bulb holder (U.S.A.) |
| 2. Rubber seal. | 4. Bulb.                | 6. Three pin socket.    |
- Inset shows bulb holder for all models except U.S.A.*

The setting of the lamps can best be carried out by placing the car in front of a blank wall at the greatest possible distance, taking care that the surface on which the car is standing is level and not sloping relative to the wall.

It will be found an advantage to cover one lamp while setting the other.

N.22

### Section N.29

#### REPLACING A LIGHT UNIT

In the event of damage to either the front lens or reflector, a replacement light unit must be fitted as follows :—

- (1) Remove the light unit as already described.
- (2) Withdraw the three screws from the unit rim and remove the seating rim and unit rim from the light unit.
- (3) Position the replacement light unit between the unit rim and setting rim, taking care to see that the die cast projection at the edge of the light unit fits into the slot in the seating rim, and also check that the seating rim is correctly positioned. Finally secure in position by means of the three fixing screws.

**Note.**—In order to comply with the lighting regulations in certain States of America, a sealed beam unit must be fitted in place of the Lucas light unit.

Cars intended for the American market are fitted with special headlamp bulb adaptors and Ward and Goldstone sockets.

When replacing a Lucas Light Unit by a Sealed Beam Unit, it is only necessary when connecting up to withdraw the Lucas adaptor from the Ward and Goldstone socket. The socket can then be plugged directly to the Sealed Beam Unit.

### Section N.30

#### HEADLAMP DIPPING SWITCH

##### To Remove

The switch is foot-operated and is mounted on a bracket welded to the floor assembly.

- (1) Remove the two screws securing the switch to the bracket and withdraw the switch.
- (2) Disconnect the three cables from the connectors.
- (3) Check the operation of the dip switch. Lightly smear the mechanism with petroleum jelly. A faulty switch must be renewed as a complete unit.

##### To Replace

The installation of the switch is a reversal of the procedure "To Remove". Reconnect the cables in accordance with the colour code given in the wiring diagram.

### Section N.31

#### HORN-PUSH AND DIRECTION INDICATOR SWITCH

##### Description

The combined horn-push and direction indicator switch is mounted on the steering wheel hub and comprises a spring-metal push covering the hub with the

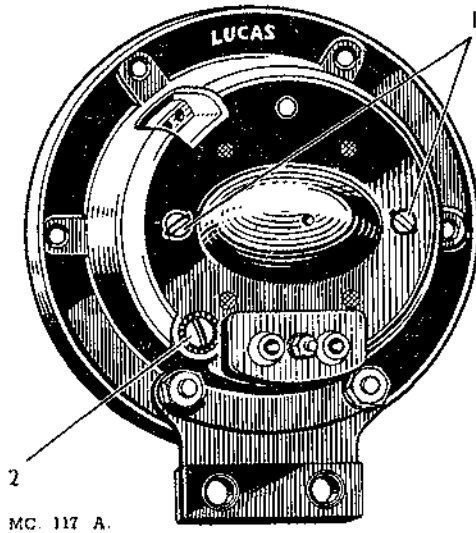

Fig. N.27. Rear view of the horn.

1. Coil securing screws. 2. Adjustment screw.

indicator switch lever positioned in its centre. The switch cables pass through a short tube attached to the hub of the horn-push and through a long tube down the steering column shaft secured by an olive in the base of the steering box. When the push is depressed, it is earthed through the steering column, permitting current to flow from the feed cable and terminal to earth, thus completing the circuit.

#### To Remove

- (1) Disconnect, at the nearest snap connections, the horn and flasher light cables protruding from the end of the stator tube.
- (2) Slacken the three grub screws in the steering wheel hub and pull out the horn quadrant together with the short piece of stator tube, horn and flasher light cables.

**Note.**—The short piece of stator tube has an indentation in it which engages in a slot located in the long tube remaining within the steering column. The horn quadrant should, therefore, be pulled straight out of the column and twisting motion avoided to eliminate any possibility of enlarging the slot in the long tube which would result in excessive movement of the horn quadrant after replacement.

- (3) Clean and examine the switch assembly, this can only be renewed as a complete assembly.
- (4) Renew any cables which are damaged.

#### To Replace

The replacement of the horn button and indicator switch is the reversal of the procedure "To Remove", reconnect the cables in accordance with the colour code given in the wiring diagram.

**Note.**—In order to facilitate the threading of the horn and flasher cables through the long tube it is advisable to tape the cable ends together.

### Section N.32

#### COMBINED SIDE AND FLASHER LIGHTS BULB To Remove

- (1) Prise back the rubber lip and insert a screwdriver blade under the glass retaining collar.
- (2) Lever the collar out from the lamp body.
- (3) Remove the lamp glass and unscrew the bulb.

#### To Replace

The installation of a side lamp bulb is a reversal of the procedure "To Remove".

### Section N.33

#### COMBINED STOP, TAIL AND FLASHER LIGHT BULBS

For details see section N.32.

### Section N.34

#### REAR NUMBER PLATE LIGHT BULB

#### To Remove

- (1) Unscrew the screw securing the lamp cover and lift off the cover.
- (2) Remove the bulb.

#### To Replace

The installation of a stop/tail light bulb is a reversal of the procedure "To Remove".

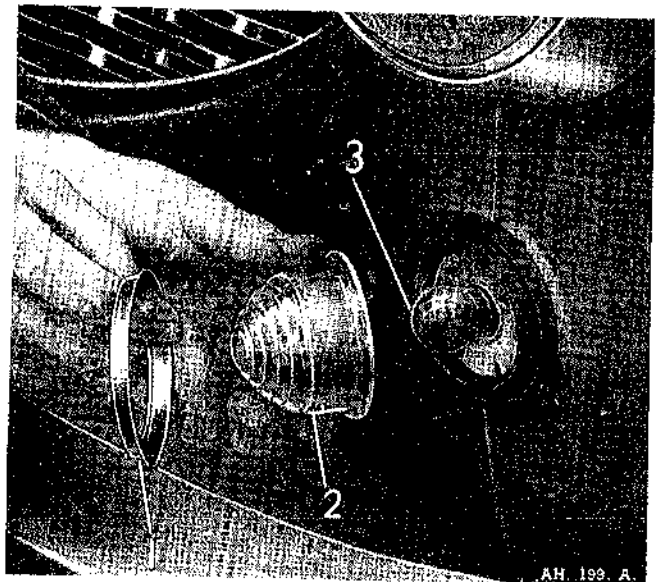

Fig. N.28. Combined side and flasher light in exploded form.  
1. Light rim. 2. Glass. 3. Bulb.

### Section N.35

### FAULT DIAGNOSIS

Symptom	No.	Possible Fault
(a) Battery discharged	1	Terminals loose or dirty
	2	Lighting circuit shorted
	3	Generator not charging
	4	Regulator unit not operating properly
	5	Battery internally defective
(b) Insufficient current flow to battery	1	Loose or corroded terminal connections
	2	Generator belt slipping
(c) Battery fails to retain charge	1	Electrolyte levels low
	2	Battery plates badly sulphated
	3	Electrolyte leakage due to cracked cell or sealing compound
	4	Plate separators not effective
(d) Battery overcharged	1	Voltage regulator out of adjustment
(e) Generator not charging properly or inoperative	1	Driving belt slipping or broken
	2	Regulator unit not operating properly
	3	Badly worn bearings or pole pieces loose
	4	Short between commutator bars
	5	Armature worn or shaft bent
	6	Commutator out of round
	7	Insulation high between commutator bars
	8	Commutator greasy, glazed or burned
	9	Brush springs weak or broken
	10	Brushes sticking
	11	Field coils shorted, open or burned

# ELECTRICAL SYSTEM

N

Symptom	No.	Possible Fault
(f) Starter motor lacks power or fails to turn the engine	1	Battery in need of attention
	2	Loose or broken connection in starter circuit
	3	Starter motor pinion jammed in mesh with flywheel gear
	4	Starter switch faulty
	5	Brushes worn, sticking or not bedded
	6	Engine abnormally stiff
	7	Commutator dirty or worn
	8	Starter shaft bent
(g) Starter motor operates but does not turn the engine	1	Pinion sticking on the screwed sleeve
	2	Broken pinion or flywheel gear teeth
(h) Noise from starter pinion when engine is running	1	Restraining spring weak or broken
(j) Starter motor inoperative	1	Battery needs attention
	2	Loose or broken connection in starter circuit or switch
	3	Armature faulty
	4	Field coils earthed
(k) Starter motor rough or noisy engagement	1	Starter motor loose on mounting bolts
	2	Damaged pinion and/or flywheel gear teeth
	3	Main spring broken
(l) Lamps inoperative	1	Battery discharged
	2	Lamp bulbs burned out
	3	Loose or broken connections
	4	Lighting switch faulty
(m) Lamps operate when switched on but gradually fade out	1	Battery discharged
(n) Lamps give insufficient illumination	1	Battery in low state of charge
	2	Headlamps out of alignment
	3	Bulbs discoloured through use
	4	Reflector surface deteriorated

# N

## ELECTRICAL SYSTEM

Symptom	No.	Possible Fault
(o) Lamps erratic	1 2 3	Lights switch contacts faulty Battery to earth connections faulty Lamp earth faulty
(p) Flashing indicator warning lamp or direction indicator lamp inoperative	1	Check the bulbs and renew if necessary Also see "Section N.15"
(q) Horn inoperative	1 2 3	Fuse blown Faulty connection Horn faulty internally
(r) Horn operates continuously	1 2	Horn-push stuck or earthed Horn cable (brown and black) to horn-push earthed
(s) Horn note unsatisfactory	1 2	Loose cable connection Horn out of adjustment
(t) Wiper motor inoperative or takes no current	1 2 3 4 5	Fuse blown Battery needs attention Loose or broken connection in the motor circuit Armature faulty Field coils earthed
(u) Wiper motor takes abnormally low current	1 2 3 4	Battery needs attention Armature faulty Commutator dirty Brushes worn or not bedded
(v) Wiper motor sluggish and takes abnormally high current	1 2 3 4	Armature faulty Armature bearings out of alignment Commutator dirty or short-circuited Wheelbox spindle binding or bent
(w) Wiper motor operates but does not drive the wiper arms	1 2 3	Wheelbox gear and spindle worn Driving cable rack faulty Gearbox components worn
(x) Fuel gauge fails to register	1 2 3	Gauge supply interrupted Gauge case not earthed Cable between gauge and tank unit earthed
(y) Fuel gauge registers full	1	Cable between gauge and tank unit broken or disconnected



# ELECTRICAL SYSTEM

N

## MODIFICATION REFERENCES

<i>Service Reference Number</i>	<i>Date</i>	<i>Subject</i>	<i>Details of Changes</i>



# SECTION O

## WHEELS AND TYRES

Section No. O.1	Description
Section No. O.2	Adjustments in the vehicle
Section No. O.3	Wheel and tyre assemblies (tubeless)
Section No. O.4	Wheel and tyre assemblies (spoke wheels)
Section No. O.5	Factors affecting tyre life and performance
Section No. O.6	Tyre and wheel balance
Section No. O.7	Lifting gear
Section No. O.8	Fault diagnosis

---



## Section O.1

### DESCRIPTION

The Austin-Healey 100 'Six' is fitted with 5.90—15 tubeless tyres upon 15×4J ventilated steel disc wheels, or, as an optional alternative, with 5.90—15 Dunlop Road Speed tyres upon 15×4J wire spoked wheels with knock-on type hub caps.

## Section O.2

### ADJUSTMENTS IN THE VEHICLE

The purpose of the following adjustments is to obtain the best performance from the wheels and tyres. Proceed as detailed below. Other faults should be diagnosed after consulting Section O.5.

- (1) Tighten the road wheel nuts (or knock-on hub caps).
- (2) Check the tyre pressures regularly with a gauge and inflate them to the recommended pressures.
- (3) Change the position of the wheel and tyre assemblies at the recommended intervals.
- (4) Remove any oil, grease or foreign objects from the tyres.

## Section O.3

### WHEEL AND TYRE ASSEMBLIES (Tubeless)

#### To Remove

- (1) Apply the handbrake and scotch one of the wheels.
- (2) Jack up the vehicle sufficiently to ensure that the wheel with a fully inflated tyre can be removed or installed.

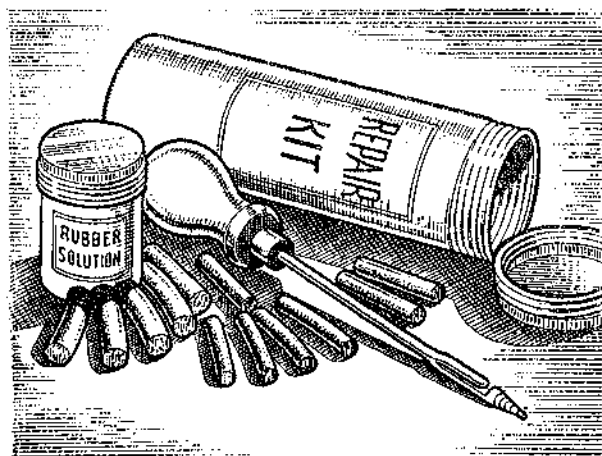

Fig. O.1. Tyre Repair Kit.

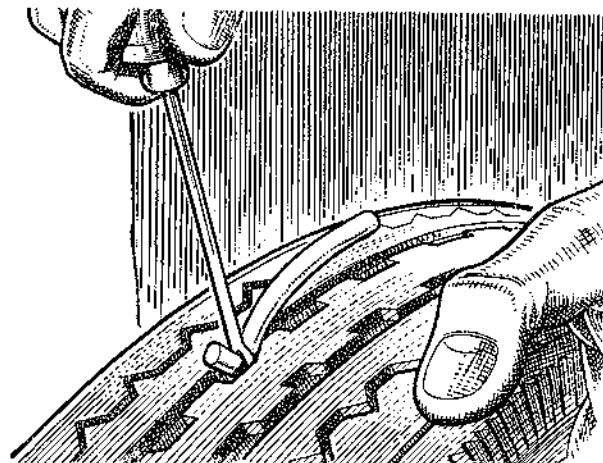

Fig. O.2. Inserting the plug and needle through the hole in the tyre.

- (3) Remove the hub cover.
- (4) Remove the five wheel nuts, which have right-hand threads, *i.e.* turn anti-clockwise to loosen. Lift off the wheel.

#### To Repair Simple Tyre Penetrations

Normally a tubeless tyre will not leak as the result of penetration by a nail or other normal puncturing objects provided that it is left in the tyre, but a repair should be effected at the earliest convenient time.

In the case of a nail penetrating the tyre, a repair can be carried out externally without removing the tyre from the rim, providing the special repair kit is available. If the hole fails to seal, mark the spot and extract the nail, taking note of the direction of penetration. If the tyre is leaking and the puncturing object cannot be located by sight, immerse the wheel and tyre in water.

Repair the tyre as follows :—

- (1) Insert the needle of the repair kit through the hole in the tyre in the same direction as the penetration to free it from road grit. Dip the needle into the rubber solution and re-insert it through the hole, repeating this operation until the hole is well lubricated with the solution.
- (2) Select a repair plug of about twice the diameter of the puncturing object, stretch and roll it into the eye of the needle, about  $\frac{1}{4}$  in. (6 mm.) from its end. Dip the plug into the rubber solution and insert the needle through the hole in the tyre so that the end of the rubber plug passes through the hole into the interior of the tyre. Withdraw the needle, leaving the plug in the tyre, and cut off the plug about  $\frac{1}{4}$  in. (3 mm.) from the surface of the tread.
- (3) Inflate the tyre (see "To inflate the tyre").

**To Dismantle**

- (1) Lay the wheel on the ground, with the valve uppermost. Deflate the tyre by removing the valve cap and interior.
- (2) Using tyre levers, which must be in good condition, separate the beads from the rim flange in the manner shown in Fig. O.6 until both beads are in the base of the rim. As inextensible wires are incorporated in the edges of the tyre, no attempt should be made to stretch the edges over the rim as the beads must in **NO WAY BE DAMAGED**. Keep the levers moistened with water.
- (3) With the bead of the tyre held in the base of the rim at a point diametrically opposite the valve, insert a lever close to the valve and carefully lift the tyre over the rim. Using two levers at intervals of about 6 in. (15 cm.) apart, continue to lift the tyre bead over the rim until this bead is entirely free.

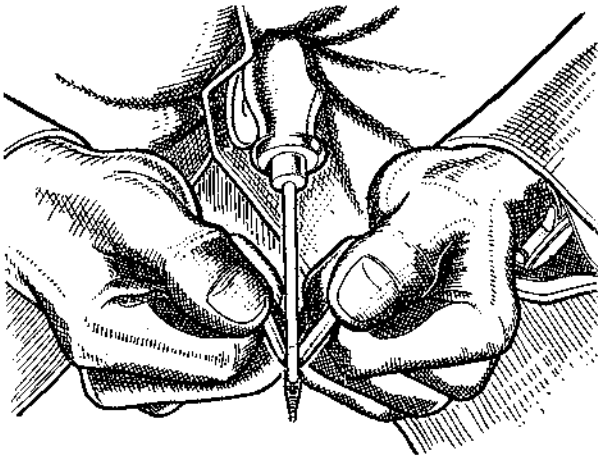

Fig. O.3. Rolling the plug into the needle eye.

- (4) Stand the tyre and wheel upright, keeping the bead in the base of the rim. Lever the bead over the rim flange, and at the same time push the wheel away from the tyre with the other hand to completely remove the tyre off the wheel.

**To Repair Severe Tyre Penetrations**

Severe penetrations which are outside the scope of the small repair kit can be repaired in a similar manner to conventional covers which will necessitate the removal of the tyre (see above).

Repair the tyre as follows:—

- (1) Inspect the tyre for damage and remove any puncturing objects.

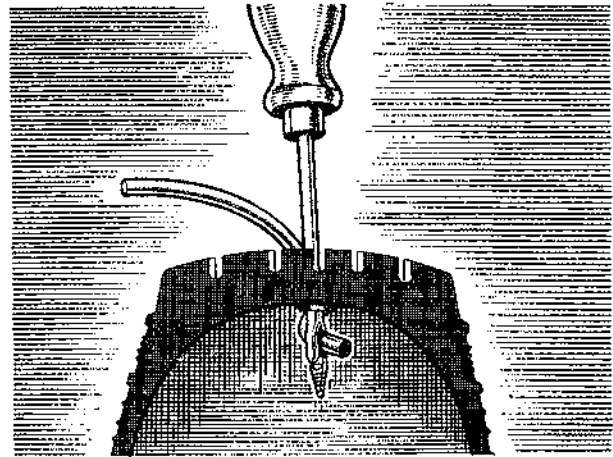

Fig. O.4. The inserted plug prior to withdrawing the needle.

- (2) Clean the area around the hole on the inside of the tyre, roughen with a scratchbrush and apply a rubber solution to the surface to receive an ordinary tube patch such as the Dunlop "Vulcafix" patch, or preferably use an uncured rubber patch and vulcanise it in position.
- (3) In the event of more serious damage, the tubeless tyre can undergo a major vulcanised repair in the same way as a normal tyre. The tubeless tyre can also be re-treaded.

**To Prepare the Rim before Fitting the Tyre**

- (1) Examine the condition of the wheel and renew if cracked, or if the attachment holes are elongated.
- (2) Check for loose rivets in the base of the wheel rim and fit oversize rivets if necessary, ensuring that they do not protrude beyond the height of the original rivets. An airtight seat must be maintained.

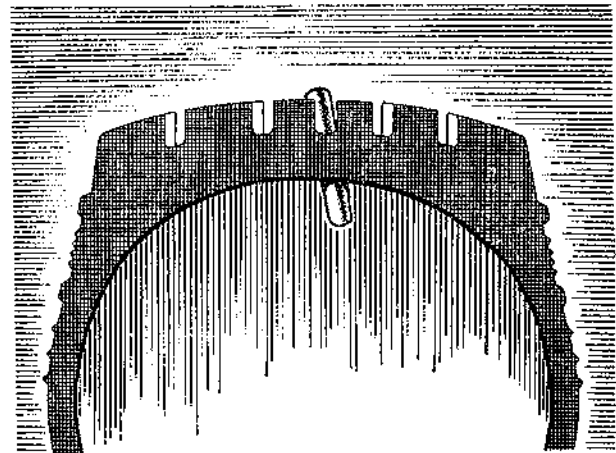

Fig. O.5. Plug inserted in the tyre and cut-off.

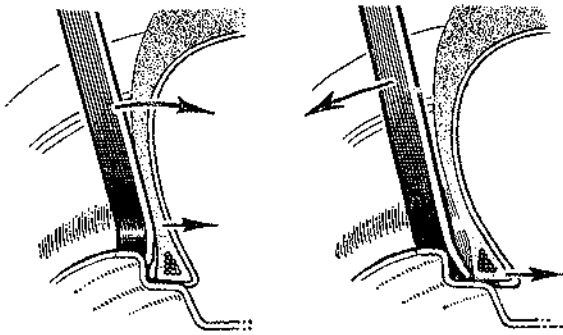

Fig. O.6. Removing a tyre bead off the rim.

- (3) Clean off all rust, rubber, etc., from the wheel flange and rim seat, using steel wool, emery or similar cleaning medium. In extreme cases of rusty rims it may be necessary to use a wire brush or even a file.
- (4) Remove any dents in the flange by hammering out carefully to maintain an airtight seat.
- (5) High spots in the welded joint of the rim must be filed or buffed away.

### To Renew a Valve

A valve should never be refitted once it has been removed from the rim, and it should be renewed every time a new tyre is fitted.

Cut out or pull outwardly the old valve from the rim.

Lubricate a new valve with soap solution and pull it through the rim hole from the inside. The valve should be pulled until the flange on the rubber base of the valve is in full contact with the inner rim surface. If the valve is pulled too far, the base will be damaged and another new valve will have to be fitted.

The use of the Schrader valve mounting Tool No. 553 is recommended, so as to avoid damage.

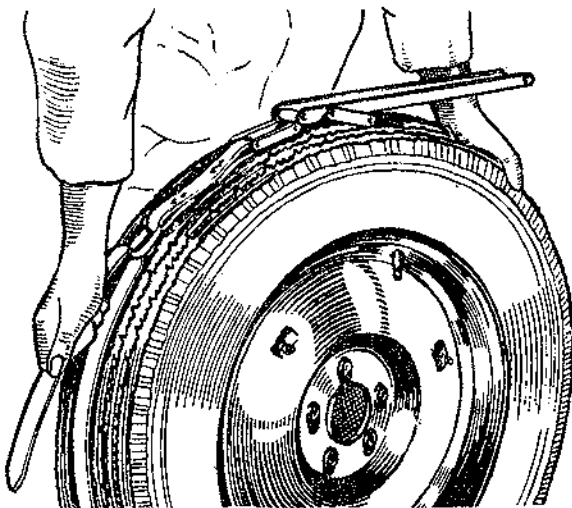

Fig. O.7. The use of a tourniquet to seal the beads.

### To Reassemble

When replacing the tubeless tyre a similar technique has to be employed to that used for removal, first fitting the tyre into the base of the rim at a point opposite the valve. Make sure the valve interior is removed and that the balance spots near the tyre bead are at the valve position. Wipe clean and moisten the beads of the tyre, rim flanges and tyre levers with clean water. Do not use petrol. Carry out the final fitting of the tyre, using levers which are in good condition and free from burrs. Take small "bites" with the levers.

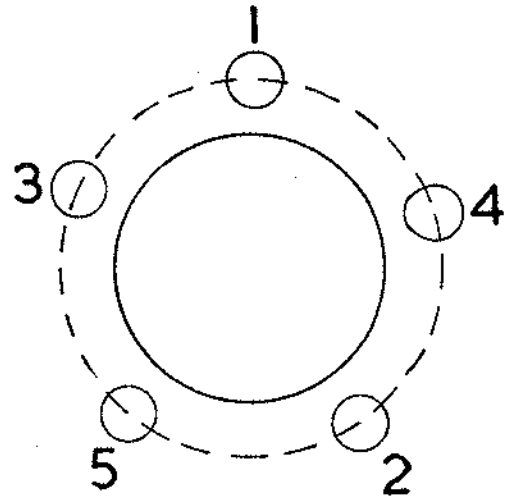

Fig. O.8. Order of tightening the wheel nuts (disc wheels).

### To Inflate the Tyre

- (1) Before inflating the tyre, bounce the crown of the tyre on the ground at various points round its circumference, to snap the beads home against the rim. This will provide a partial seal.
- (2) Connect an air line to the valve, with its interior plunger omitted, and inflate the tyre with the wheel in an upright position. If a seal cannot be effected by the first rush of air, bounce the tyre on its crown at various points round the circumference with the air line still attached. In cases of difficulty apply the special tourniquet consisting of a strap incorporating a lever, but a suitably strong cord or rope around the circumference of the tread and a twisting bar or stick will also serve. If no air line is available and the tyre has to be inflated by a foot- or hand-pump, then the use of a tourniquet is essential to force the beads outwards against the rim flanges to effect a seal. Remove the air line, insert the valve interior and re-inflate, for test purposes, to 50 lb./sq. in. (3.5 kg./cm.<sup>2</sup>).

- (3) Allow the tyre to stand for a few minutes so that any free air trapped between the flange and the bead clinch can escape. Test the complete assembly in a water tank to check for leaks, special attention being paid to the areas at the beads, valve and wheel rivets. Should leakage occur at the valve base, this can only be rectified by renewing the valve. Loss of air around the bead seat and flange is generally due to a high spot on the rim (foreign matter, rust, weld, etc.) and in most cases this can be cured by holding the tyre bead away from the rim, with the tyre deflated, in order to effect further cleaning of the rim bead seat with emery, steel wool, etc. Air leakage at the rivets can be remedied by peening over the rivet head with a ball-pane hammer. The rivet should be backed up with another, and preferably larger, hammer. In extreme cases where major leaks occur at the flanges or rivets, mark off the position of the leaks on the tyre and the rim before removing the tyre for inspection and rectification.
- (4) When satisfied that there are no air leaks, and that the tyre is correctly fitted, adjust the tyre to the recommended working pressure.

#### To Replace

- (1) Install the wheel and tyre assembly on the hub.
- (2) Screw on the wheel nuts, which have right-hand threads, *i.e.* turn in a clockwise direction, and tighten them in the sequence shown in Fig. O.8.
- (3) Release the jack and scotch; check the wheel nuts again.
- (4) Place the rim of the hub cover over two of the buttons on the wheel centre and give the outer face a sharp blow of the fist over the third button.

## Section O.4

### WHEEL AND TYRE ASSEMBLIES (Spoke Wheels)

#### Wheel Changing

- (1) First loosen the "knock-on" hub cap, then jack up the car. If it is a front wheel which is to be changed the lip on the platform of the screw type jack must project into the recess in the spring plate, whilst the platform should be across the outer rim of the spring plate, the flat end between the lower wishbone links.
- (2) For lifting the rear wheels, place the lifting platform across the lowest spring leaf, to the rear of the axle, with the lipped end on the outside of the spring and up against the spring "U" bolt, this avoids any turning movement.

After jacking, the hub cap can be screwed right off. The wheel is then pulled off the splined hub.

- (3) Refitting the wheel is simply a reversal of this removal procedure, but the splines of the hub and wheel are so fine that the operator should be careful lest in his haste he jams the splines. A little grease should be smeared upon the splines and cone faces of the hub and wheel before refitting. The hub cap threads will also benefit from an occasional application of grease.

Remember that hub caps fitted to right-hand side hubs have left-hand threads, left-hand hubs have right-hand threads, however, the direction for turning is clearly marked on each cap. Caps should be finally tightend with a mallet.

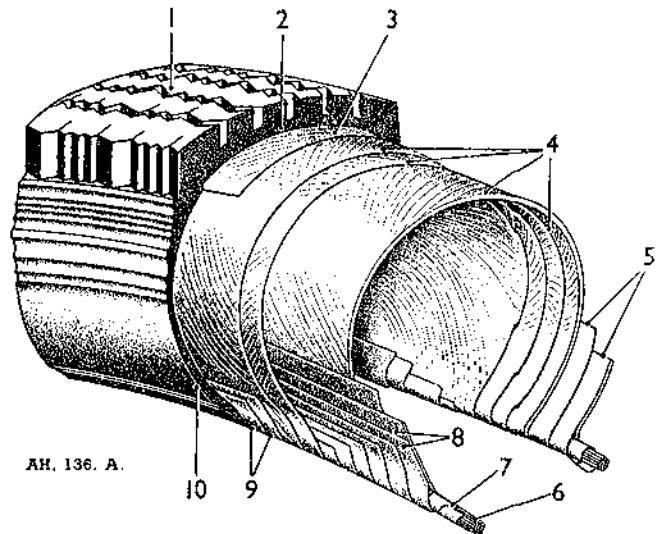

AH, 136. A.

Fig. O.9. Diagrammatic illustration of tyre construction.

- |                         |                   |                  |
|-------------------------|-------------------|------------------|
| 1. Tread.               | 4. Casing plies.  | 8. Fillers.      |
| 2. Soft cushion rubber. | 5. Fillers.       | 9. Chafers.      |
| 3. Breaker.             | 6. Bead wires.    | 10. Wall rubber. |
|                         | 7. Bead wrapping. |                  |

#### Tyre Removal

- (1) Remove all valve parts to deflate the tyre and push both tyre beads off the rim seats.
- (2) Commence to remove the bead on the valve side of the cover. Insert a lever at the valve position and, while pulling on this lever, push the bead into the well of the rim diametrically opposite the valve.
- (3) Insert a second lever about 2 in. away from the first lever and gradually prise the bead over the rim flange.
- (4) Continue with one lever while holding the removed portion of the bead with the other lever. The tube can then be removed.



- (5) Stand the cover upright with the wheel in front.
- (6) Insert a lever from the front between the bead and the flange and pull the cover back over the flange.
- (7) If difficult to remove, keep the strain on the bead with the lever and tap off with a rubber mallet.

### Tyre Replacement

- (1) Place the cover on top of the wheel and push as much as possible of the lower bead by hand into the well of the rim. Insert a lever to prise the remaining portion of the lower bead over the rim flanges.
- (2) Slightly inflate the tube until it begins to round out and insert it in the cover with the valve through the hole in the rim. Take care that the valve, which is fitted in the side of the tube, is on the correct side of the rim and that the tube and spot markings coincide; a point of balance already described.
- (3) Commence to fit the second bead by pushing it into the well of the rim diametrically opposite the valve.

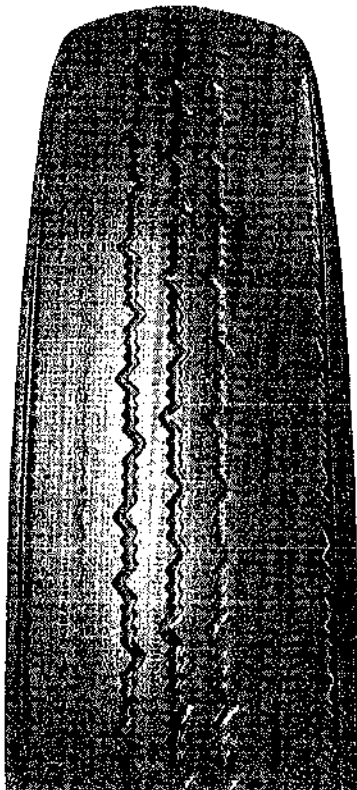

AH. 163. A.

*Fig. O.10. Excessive tyre distortion from persistent underinflation causes rapid wear on the shoulders and leaves the centre standing proud. If the effects of underinflation are aggravated by other factors, such as camber and excessive braking, the irregular and rapid wear is more pronounced.*

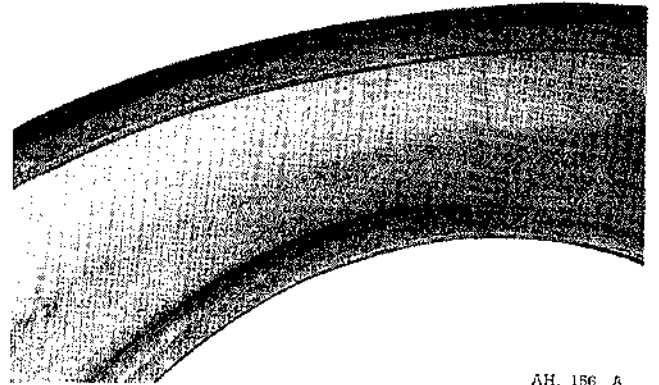

AH. 156. A.

*Fig. O.11. This casing is breaking up due to over-flexing and heat generation.*

- (4) Lever the bead over the flange either side of this position, finishing at the valve, when the bead will be completely fitted.
- (5) Ease the valve in the rim hole and push upwards by hand to enable the beads to seat correctly and then pull the valve firmly back into position.
- (6) Inflate the tyre and see that the beads are seated evenly round the rim: check by the line on the cover.

**Note:** Water on levers considerably eases the fitting and removing of beads.

## Section O.5

### FACTORS AFFECTING TYRE LIFE AND PERFORMANCE

#### Inflation Pressures

All other conditions being favourable there is an average loss of 13% tread mileage for every 10% reduction in inflation pressure below the recommended figure.

A tyre is designed so that there is a minimum pattern shuffle on the road surface and a suitable distribution of load over the tyres contact area when deflection is correct.

Moderate underinflation causes an increased rate of tread wear although the tyre's appearance may remain normal. Severe and persistent underinflation produces unmistakable evidence on the tread, see fig. O.10. It also causes structural failure due to excessive friction and temperature within the casing, figs. O.11 and O.12.

Pressures which are higher than those recommended for the car reduce comfort. They may also reduce tread

# O

## WHEELS AND TYRES

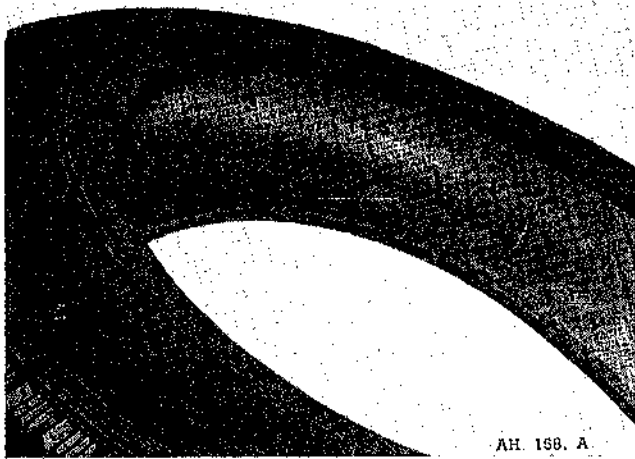

Fig. O.12. Running deflated has destroyed this tyre.

life due to a concentration of the load and wear on a smaller area of tread, aggravated by increased wheel bounce on uneven road surfaces. Excessive pressures overstrain the casing cords, in addition to causing rapid wear, and the tyres are more susceptible to impact fractures and cuts.

### Effect of Temperature

Air expands with heating and tyre pressures increase as the tyres warm up. Pressures increase more in hot weather than in cold weather and as a result of high speed. These factors are taken into account when designing the tyre and in preparing Load Pressure schedules.

Pressures in warm tyres should not be reduced to standard pressure for cold tyres. "Bleeding" the tyres increases their deflections and causes their temperatures to climb still higher. The tyres will also be underinflated when they have cooled.

### Speed

High Speed is expensive and the rate of tread wear may be twice as fast at 50 m.p.h. as at 30 m.h.p.

High speed involves :---

- (1) Increased tyre temperatures due to more deflections per minute and a faster rate of deflection and recovery. The resistance of the tread to abrasion decreases with increase of temperature.
- (2) Fierce acceleration and braking.
- (3) More tyre distortion and slip when negotiating bends and corners.
- (4) More "thrash" and "scuffing" from road surface irregularities.

### Braking

"Driving on the brakes" increases the rate of tyre wear, apart from being generally undesirable. It is not

necessary for wheels to be locked for an abnormal amount of tread rubber to be worn away.

Other braking factors not directly connected with the method of driving can affect tyre wear, for instance correct balance and lining clearances, and freedom from binding, are very important. Braking may vary between one wheel position and another due to oil or foreign matter on the shoes even when the brake mechanism is free and correctly balanced.

Brakes should be relined and drums reconditioned in complete sets. Tyre wear may be affected if shoes are relined with non-standard material having suitable characteristics or dimensions, especially if the linings differ between one wheel position and another in such a way as to upset the brake balance. Front tyres, and particularly near front tyres, are very sensitive to any condition which adds to the severity of front braking in relation to the rear.

"Picking-up" of shoe lining leading edges can cause grab and reduce tyre life. Local "pulling-up" or flats on the tread pattern can often be traced to brake drum eccentricity, fig. O.13. The braking varies during each wheel revolution as the minor and major axis of the eccentric drum pass alternately over the shoes. Drums should be free from excessive scoring and be true when mounted on their hubs with the road wheels attached.

### Climatic Conditions

The fate of tread wear during a reasonably dry and warm summer can be twice as great as during an average winter.

Water is a rubber lubricant and tread abrasion is much less on wet roads than on dry roads. In addition resistance of the tread to abrasion decreases with increase in temperature.

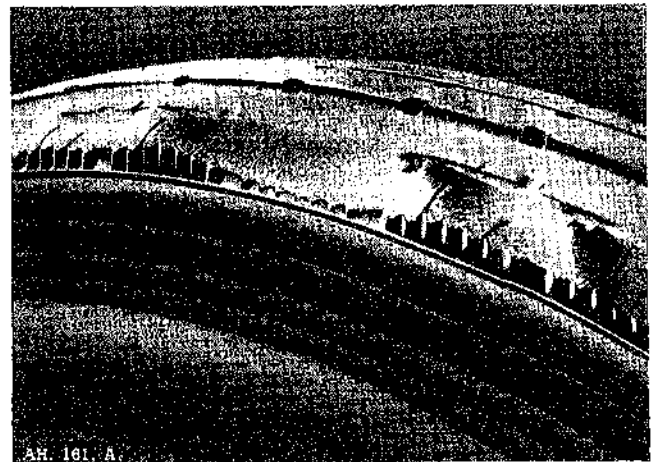

Fig. O.13. Local excessive wear due to brake drum eccentricity.

When a tyre is new its thickness and pattern depth are at their greatest. It follows that heat generation and pattern distortion due to flexing, cornering, driving and braking are greater than when the tyre is part worn.

Higher tread mileages will usually be obtained if new tyres are fitted in the autumn or winter rather than in the spring or summer. This practice also tends to reduce the risk of road delays because tyres are more easily cut and penetrated when they are wet than when they are dry. It is, therefore, advantageous to have maximum tread thickness during wet seasons of the year.

### Road Surface

Present day roads generally have better non-skid surfaces than formerly. This factor, combined with improved car performance, has tended to cause faster tyre wear, although developments in tread compounds and patterns have done much to offset the full effects.

Road surfaces vary widely between one part of the country and another, often due to surfacing with local material. In some areas the surface dressing is coarser than others; the material may be comparatively harmless rounded gravel, or more abrasive crushed granite, or knife-edged flint. Examples of surfaces producing very slow tyre wear are smooth stone setts and wood blocks, but their non-skid properties are poor.

Bends and corners are severe on tyres because a car can be steered only by misaligning its wheels relative to the direction of the car. This condition applies to the rear tyres as well as the front tyres. The resulting tyre slip and distortion increase the rate of wear according to speed, load, road camber and other factors, fig. O.14.

The effect of hills, causing increased driving and braking torques with which the tyres must cope, needs no elaboration.

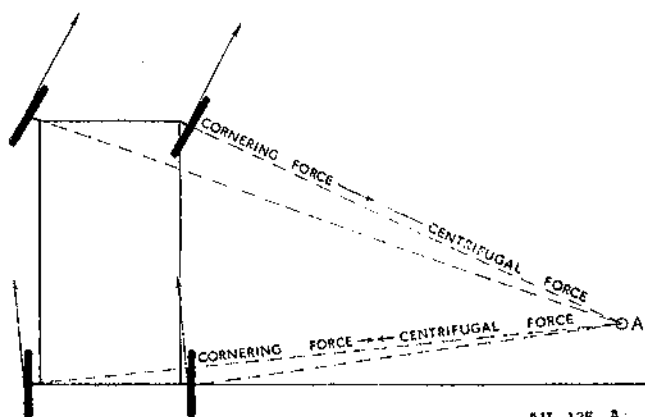
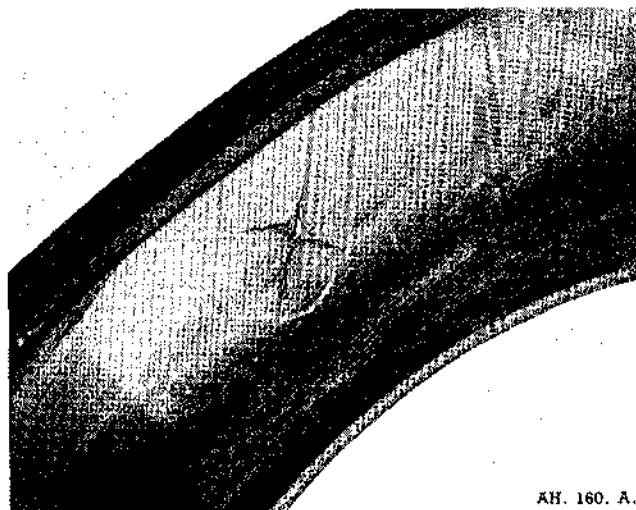

Fig. O.14. Slip when cornering causes increased tyre wear.

### Impact Fractures

In order to provide adequate strength, resistance to wear, stability, road grip and other necessary qualities.



AH. 160. A.

Fig. O.15. Severe impact has fractured the casing.

a tyre has a certain thickness and stiffness. Excessive and sudden local distortion, such as may result from striking a kerb, a large stone or brick, an upstanding manhole cover, or a deep pothole may fracture the casing cords; figs. O.15 and O.16.

Impact fractures often puzzle the car owner because the tyre and road spring may have absorbed the impact without his being aware of anything unusual. Only one or two casing cords may be fractured by the blow and the weakened tyre fails some time later. Generally there is no clear evidence on the outside of the tyre unless the object has been sufficiently sharp to cut it.

This damage is not associated solely with speed and care should be exercised at all times, particularly when drawing up to a kerb.

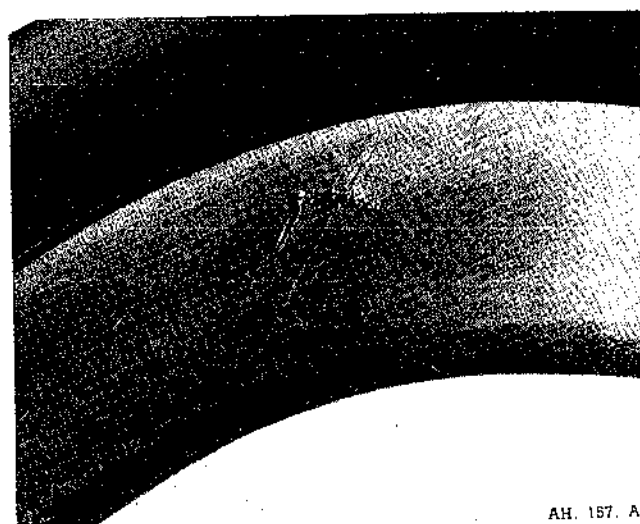

AH. 157. A.

Fig. O.16. A double fracture caused by the tyre being crushed between the rim and an obstacle, such as the edge of a kerb.

**"Spotty Wear"**

Fig. O.17 shows a type of irregular wear which sometimes develops on front tyres and particularly on near-side front tyres.

The nature of "spotty" wear—the pattern being much worn and little worn at irregular spacings round the circumference—indicates an alternating "slip grip" phenomenon, but it is seldom possible to associate its origin and development with any single cause. There is evidence of camber wear, misalignment, underinflation, or braking troubles.

It is preferable to check all points which may be contributory factors. The front tyres and wheel assemblies may then be interchanged, which will also reverse their direction of rotation, or better still the front tyres may be interchanged with the rear tyres.

Points for checking are :—

- (1) Inflation pressures and the consistency with which the pressures are maintained.
- (2) Brake freedom and balance, shoe settings, lining condition, drum condition and truth.
- (3) Wheel alignment.

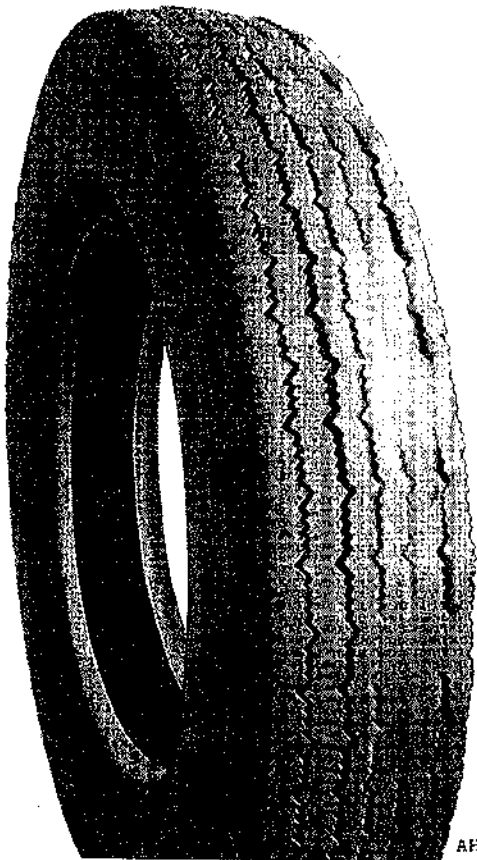

AH. 159. A.

Fig. O.17. Irregular "Spotty" wear, to which a variety of causes may contribute.

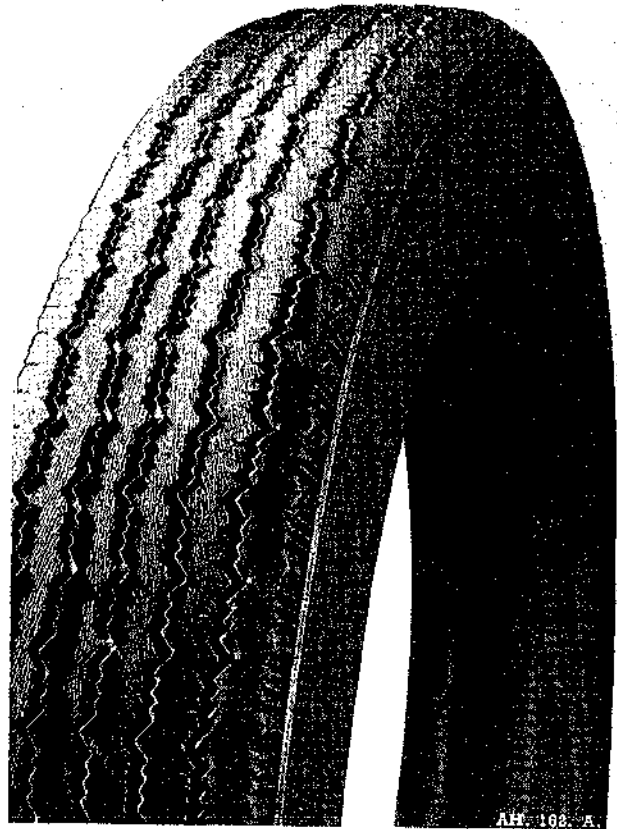

AH. 108. A.

Fig. O.18. Fins or feathers caused by severe misalignment. With minor misalignment, probably aggravated by road camber, the ribs may have sharp edges instead of upstanding fins. These conditions will usually be accompanied by heel and toe wear across the tread due to its being distorted and worn away laterally instead of in a true rolling direction.

- (4) Camber and similarity of camber of the front wheels.
- (5) Play in hub bearings, swivel pin bearings, suspension bearings, and steering joints.
- (6) Wheel concentricity at the tyre bead seats.
- (7) Balance of the wheel and tyre assemblies.
- (8) Conditions of road springs and shock absorbers.

Corrections which may follow a check of these points will not always effect a complete cure and it may be necessary to continue to interchange wheel positions and reverse directions of rotation at suitable intervals.

Irregular wear may be inherent in the local road conditions such as from a combination of steep camber, abrasive surfaces, and frequent hills and bends. Driving methods may also be involved. Irregular wear is likely to be more prevalent in summer than in winter, particularly on new or little worn tyres.

**Wheel Alignment and Road Camber**

It is very important that correct wheel alignment should be maintained. Misalignment causes a tyre tread

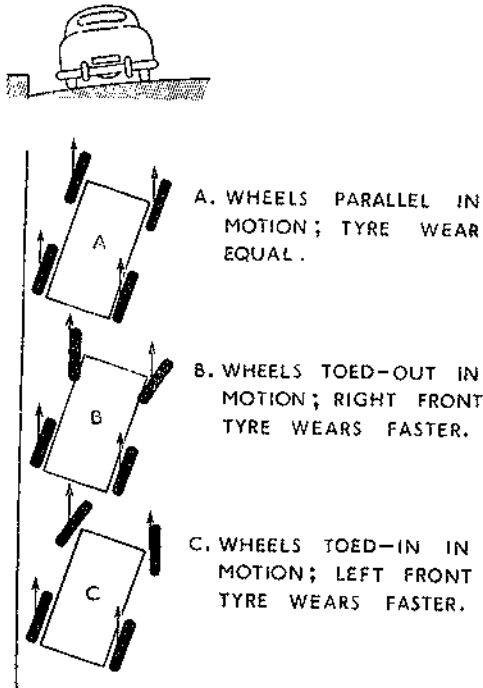

AH. 133. A.

Fig. O.19. Exaggerated diagram of the way in which road camber affects a car's progress.

to be scrubbed off laterally because the natural direction of the wheel differs from that of the car.

An upstanding fin on the edge of each pattern rib is a sure sign of misalignment and it is possible to determine from the position of the "fins" whether the wheels are toed in or toed out, see fig. O.18. Fins on the inside edges of the pattern ribs—nearest to the car—and particularly on the off-side tyre, indicate toe-out.

With minor misalignment the evidence is less noticeable and sharp pattern edges may be caused by road camber even when wheel alignment is correct. In such cases it is better to make sure by checking with an alignment gauge.

Road camber affects the direction of the car by imposing a side thrust and if left to follow its natural course the car will drift to the near side. This is instinctively corrected by steering towards the road centre. As a result the car runs crab-wise. Fig. O.19 shows, in exaggerated form, the effect this has upon the tyres.

The near front tyre sometimes persists in wearing faster and more unevenly than the other tyres even when the mechanical condition of the car and tyre maintenance are satisfactory. The more severe the average road camber the more marked will this tendency be. This is an additional reason for the regular interchange of tyres.

### Camber Angle

This angle normally requires no attention unless disturbed by a severe impact, however, it is always

advisable to check this angle if steering irregularities develop, see L.6.

Wheel camber usually combined with road camber, causes a wheel to try to turn in the direction of lean, due to one side of the tread attempting to make more revolutions per mile than the other side. The resulting increased tread shuffle on the road and the off centre tyre loading tend to cause rapid and one sided wear. If wheel camber is excessive for any reason the rapid and one sided tyre wear will be correspondingly greater. Unequal cambers introduce unbalanced forces which try to steer the car one way or the other. This must be countered by steering in the opposite direction which results in faster tread wear.

## Section O.6

### TYRE AND WHEEL BALANCE

#### Static Balance

In the interests of smooth riding, precise steering and the avoidance of high speed "tramp" or "wheel hop," all Dunlop tyres are balance checked to predetermined limits.

To ensure the best degree of tyre balance the covers are marked with white spots on one bead and these indicate the lightest part of the cover. Tubes are marked on the base with black spots at the heaviest point. By fitting the tyre so that the marks on the cover bead exactly coincide with the marks on the tube a high degree of tyre balance is achieved, see fig. O.20.

When using tubes which do not have coloured spots it is usually advantageous to fit the covers so that the white spots are at the valve position.

In the case of tubeless tyres the white balance spots near the tyre bead should be at the valve position.

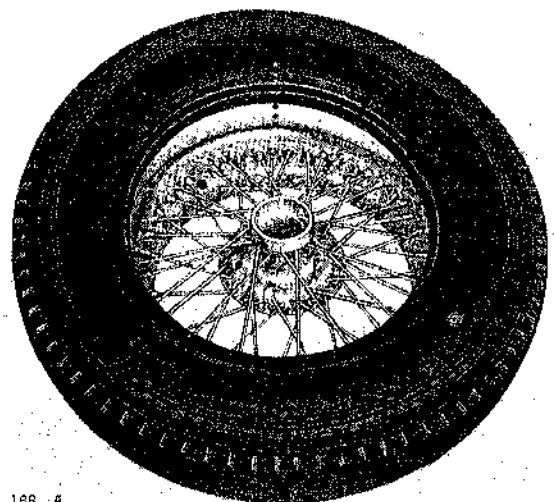

AH. 166. A.

Fig. O.20. Correct fitting relationship of Dunlop covers and tubes.

Some tyres are slightly outside standard balance limits and are corrected before issue by attaching special loaded patches to the inside of the covers at the crown. These patches contain no fabric, they do not affect the local stiffness of the tyre and should not be mistaken for repair patches—they are embossed "Balance Adjustment Rubber".

The original degree of balance is not necessarily maintained and it may be affected by uneven tread wear, by cover and tube repairs, by tyre removal and refitting or by wheel damage and eccentricity. The car may also become more sensitive to unbalance due to normal wear of moving parts.

Should roughness or high speed steering troubles develop, and mechanical investigation fails to disclose a possible cause, wheel and tyre balance should be suspected.

A tyre balancing machine is marketed by the Dunlop Company to enable service stations to deal with such cases.

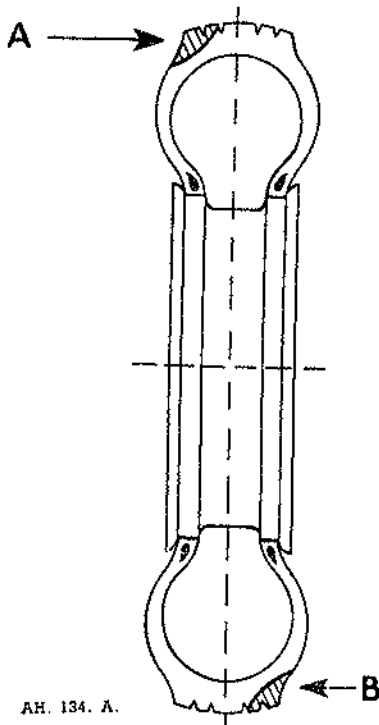

AH. 134. A.

Fig. O.21. Dynamic or couple unbalance, produces wear at 'A' and 'B'.

### Dynamic Balance

Static unbalance, as its name implies, can be measured when the tyre and wheel assembly is stationary. There is, however, another form known as dynamic unbalance which can be detected only when the assembly is revolving.

O.10

There may be no heavy spot—that is, there may be no natural tendency for the assembly to rotate about its centre due to gravity—but the weight may be unevenly distributed each side of the tyre centre line, see fig. O.21.

Laterally eccentric wheels give the same effect. During rotation the offset weight distribution sets up a rotating couple which tends to steer the wheel to right and left alternately.

Dynamic unbalance of tyre and wheel assemblies can be measured on the Dunlop tyre balancing machine and suitable corrections made when a car shows sensitivity to this form of unbalance. Where it is clear that a damaged wheel is the primary cause of severe unbalance it is advisable for the wheel to be replaced.

### Changing Position of Tyres

Reference has already been made to irregular tread wear which is confined almost entirely to front tyres and there may be different rates of wear between one tyre and another.

It is, therefore, recommended that front tyres be interchanged with rear tyres at least every 3,000 miles. Diagonal interchanging between near-side front and off-side rear and between off-side front and near-side rear provides the most satisfactory first change because it reverses the direction of rotation.

Subsequent interchanging of front and rear tyres should be as indicated by the appearance of the tyres, with the object of keeping the wear of all tyres even and uniform.

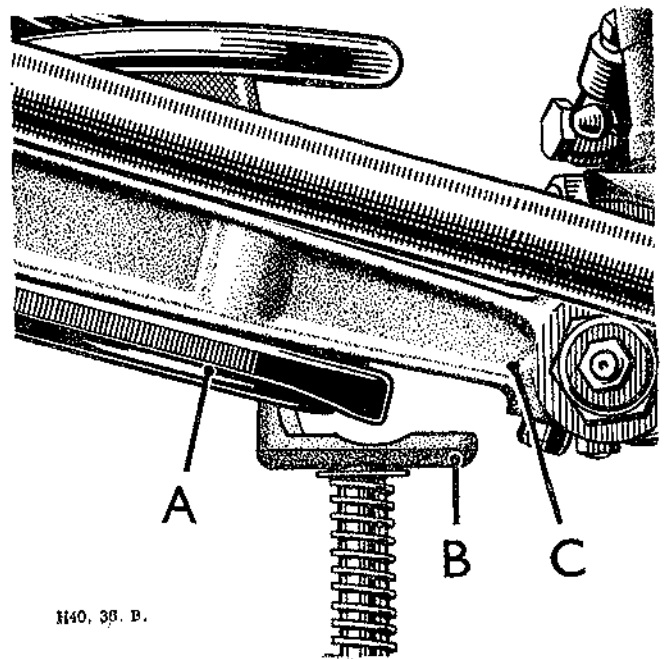

H40. 39. B.

Fig. O.22. Front position for screw jack.  
A. Front suspension spring plate. B. Jack platform.  
C. Front suspension lower wishbone arm.

**Wheel Wobble:** The lateral variation measured on the vertical inside face of a flange should not exceed  $\frac{3}{32}$  in. (2·3812 mm.).

**Wheel Lift:** On a truly mounted and revolving wheel the difference between the high and low points, measured at any location on either tyre bead seat, should not exceed  $\frac{3}{32}$  in. (2·3812 mm.).

Radial and lateral eccentricity outside these limits contribute to static and dynamic unbalance respectively. Severe radial eccentricity also imposes intermittent loading on the tyre. Static balancing does not correct this condition which can be an aggravating factor in the development of irregular wear.

A wheel which is eccentric laterally will cause the tyre to snake on the road, but this in itself has no effect on the rate of tread wear.

At the same time undue lateral eccentricity is undesirable and it affects dynamic balance.

Rim seatings and flanges in contact with the tyre beads should be free from rust and dirt.

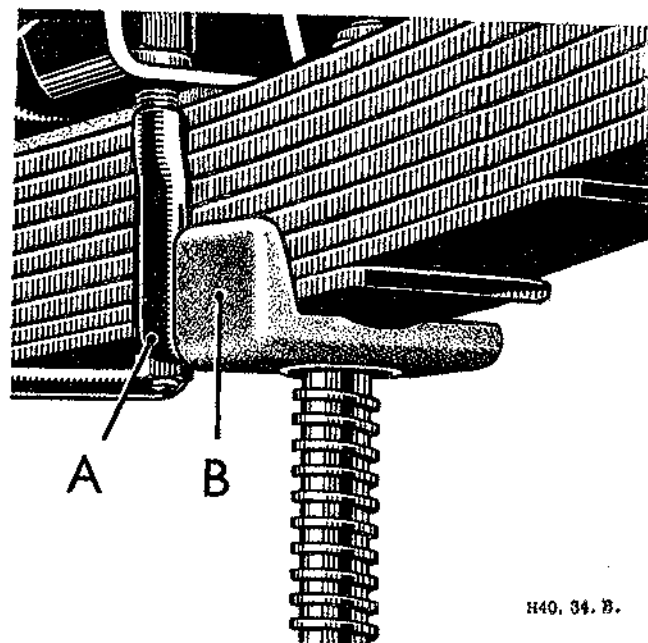

H40. 34. B.

*Fig. O.23. Rear position for screw jack.*  
A. Rear spring "U" bolt. B. Jack platform lip.

## Section O.7

### LIFTING GEAR

#### The Under-Axle Type of Screw Jack

This type of jack is used for all models. For the front wheels the lifting platform of the jack should be placed across the outer rim of the spring recess in the spring plate.

For lifting the rear wheels, place the lifting platform across the lowest spring leaf, to the rear of the axle,

with the lipped end on the outside of the lower plate, so that the flat end is between the bottom wishbone links and the lipped end projects into the spring and up against the spring U-bolt; this avoids any turning movement.

A long handle is required to operate the jack and this is obtained by joining together the provided extension and tommy bars, the latter being the turning medium.

## Section O.8

### FAULT DIAGNOSIS

Symptom	No.	Possible Fault
(a) Wheel and tyre noises	1	Wheel nuts loose or drawn up unevenly
	2	Variation in tyre tread surface (due to repaired section or break in the tyre)
	3	Foreign object embedded in the tyre tread
	4	Tyres under-inflated
(b) Abnormal tyre wear	1	Tyres consistently under-inflated
	2	Wheel nuts drawn up unevenly
	3	Front and rear axles not parallel, resulting from a broken spring centre bolt, or "U" bolt, allowing the axle to move on the spring
	4	Misalignment of the front wheels
	5	Brakes improperly adjusted





# **SECTION P**

## **BODYWORK**

Section No. P.1      Maintenance and adjustments

Section No. P.2      Dismantling





## Section P.1

### MAINTENANCE AND ADJUSTMENTS

#### Care of the Bodywork

Models which are finished in cellulose should receive regular care and attention to maintain their lustre. If neglected the paintwork will become dull and develop a bloom which is the result of exhaust fumes and other traffic vapours.

Frequent washing with clear cold running water will help to maintain its lustre but ensure that the sponge and leather used are always clean and not the same mediums used on the undercarriage.

Should the paint finish become dull, a sparing application of a reputable liquid polish will restore it.

#### Synthetic Enamel

Cars which have a synthetic enamel finish require frequent washing to retain the high degree of finish and a good emulsion polish, occasionally applied, is sufficient to preserve the paintwork. Never use a wax liquid polish on synthetic enamel.

#### Chromium

Plated parts should be finished with a damp leather. If very dirty wash the chrome with warm soapy water, but on no account use metal polish.

#### Door and Locks Hinges

Occasionally apply a few drops of oil on the moving parts of all door locks and hinges. A light touch of grease should be smeared on the lock striker plates to ensure free movement and reduce wear of the locks.

In addition, the security of door hinges, locks, dovetails and striker plates should be checked periodically with a screwdriver.

#### Upholstery

The leather work has, in general, an impermeable surface and it can be kept clean and fresh looking by an occasional wiping down with a damp cloth and saddle soap. Finish off when completely dry with a good furniture cream.

#### Carpets

Carpets are best kept in good condition by brushing or by use of a vacuum cleaner. Periodically the carpets should be removed and thoroughly beaten after which the body floor should be inspected for signs of rust.

Such spots should be cleaned and painted with a quick drying enamel before the carpets are replaced.

#### Windows

Windscreen, sidescreens, rear window and driving mirror should be cleaned with a damp leather.

## Section P.2

### DISMANTLING

#### Bonnet Top

The bonnet at its rear edge, has two brackets which form part of the hinges. A leg from the bulkhead is secured to each bracket by two nuts and bolts, therefore removal of the bonnet top is achieved by withdrawing the bolts from each bracket then lifting off the panel.

Opening of the bonnet is described in the Handbook.

#### Grille

The grille is secured at eight points, all easily accessible from beneath the car. Three  $\frac{1}{4}$  in. U.N.F. set pins will be found at the top and bottom of the grille, while one  $\frac{1}{16}$  in. U.N.F. setpin is located each side.

#### Bumper Bars

**Rear:** The rear bumper is best dismantled by releasing the two nuts immediately behind the bumper bar at the junction of bracket and bumper. The brackets supporting the bumper are secured by two setpins to each chassis frame side member accessible within the luggage compartment.

**Front:** In a manner similar to that employed for its counterpart at the rear, the front bumper bar is held by two nuts to the supporting brackets which are secured by two setpins to each chassis side member.

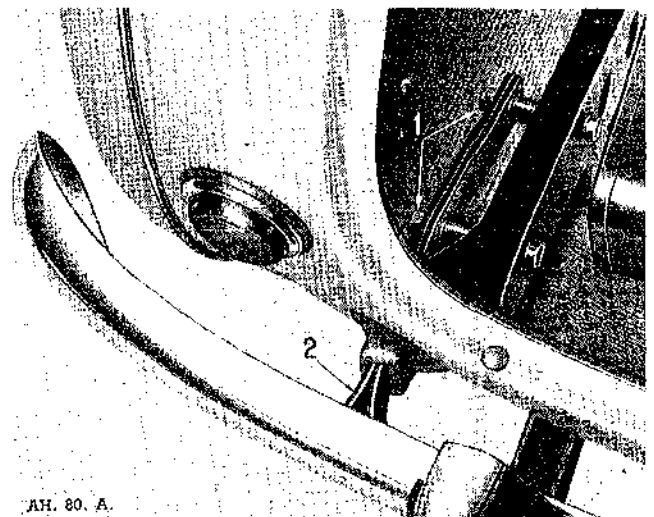

AH. 80. A.

Fig. P.1. Rear bumper fixing.

1. Fixing bolts. 2. Supporting brackets.

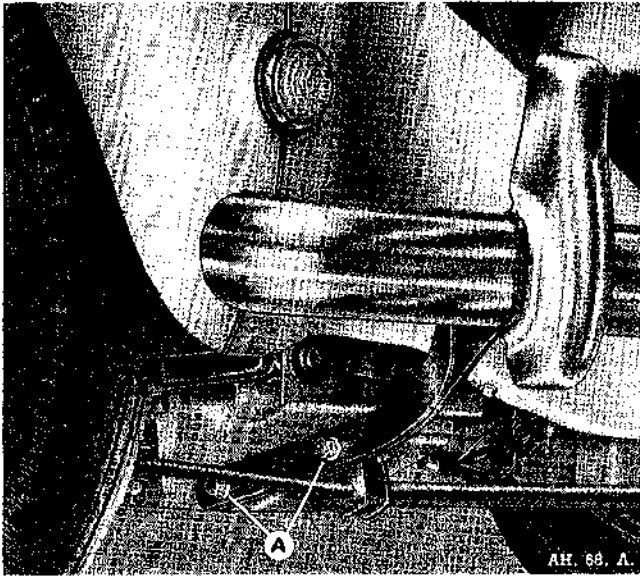

Fig. P.2. Front bumper fixing.  
A. Bracket to chassis setpins.

#### Front Apron

Once the front bumper has been released at its forward end, the apron can be readily removed from the bodywork.

#### Sidescreens and Sockets

The sidescreens each have one locating dowel at their base. These dowels are a snug push fit into sockets let into the top of each door.

If necessary the sidescreen sockets can be screwed out of the door using either a broad blade screwdriver or, preferably, a special tool which incorporates a pilot, see Fig. P.3.

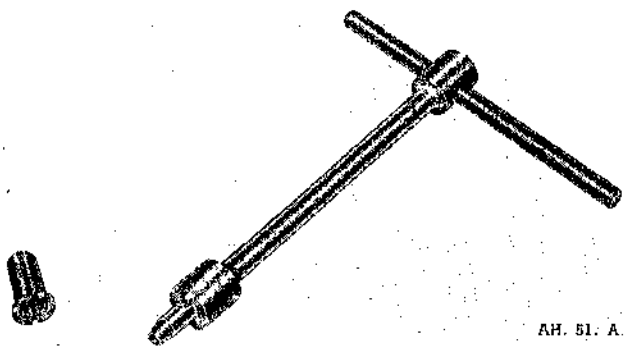

Fig. P.3. Sidescreen socket and extractor tool.

P.2

#### Doors

**Hinges and Door Removal:** Both the upper and lower hinge of each door is secured to the door post by four cross-head screws plus one hexagon head setpin. At the door frame each hinge is fixed by four cross-head screws.

There is a check strap fitted to each door which must be released when dismantling a door from the bodywork. This check strap can be released by withdrawing the two setpins from the coupling bracket in the door pillar. Thus with the door wide open, the hinges can readily be uncoupled from the door and the door removed.

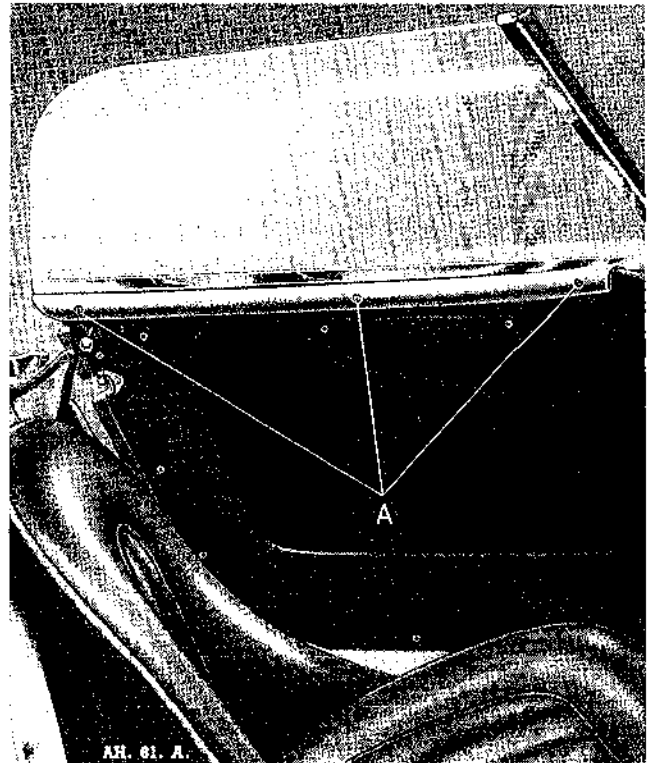

Fig. P.4. The door top moulding is held in place by three cross-head screws A.

**Casing:** Each door casing, complete with its trimming, can be removed from the door shell after its sixteen securing cross-head screws have been withdrawn from around the casing perimeter.

**Door Top Moulding:** The aluminium moulding at each door top edge is held in place by three cross-head screws.

**Outer Handles:** Each outer door handle is secured by a nut accessible from the inside of the door and a Phillip screw accessible from the outside when the handle is raised.

## BODYWORK

**Inner Handles:** To remove the door operating handle, the chrome cap behind the handle concerned must be pushed inwards against the spring pressure. When pressure to the cap is applied a dowel pin is visible, passing through the handle stem. Withdraw the pin when the handle and cap can be removed.

### Windscreen

The windscreen frame is secured to the scuttle at each side by two nuts and bolts and a single setpin. Each nut and setpin head are accessible within the cockpit behind the fascia. The bolt heads can be seen at the door pillars when the doors are open.

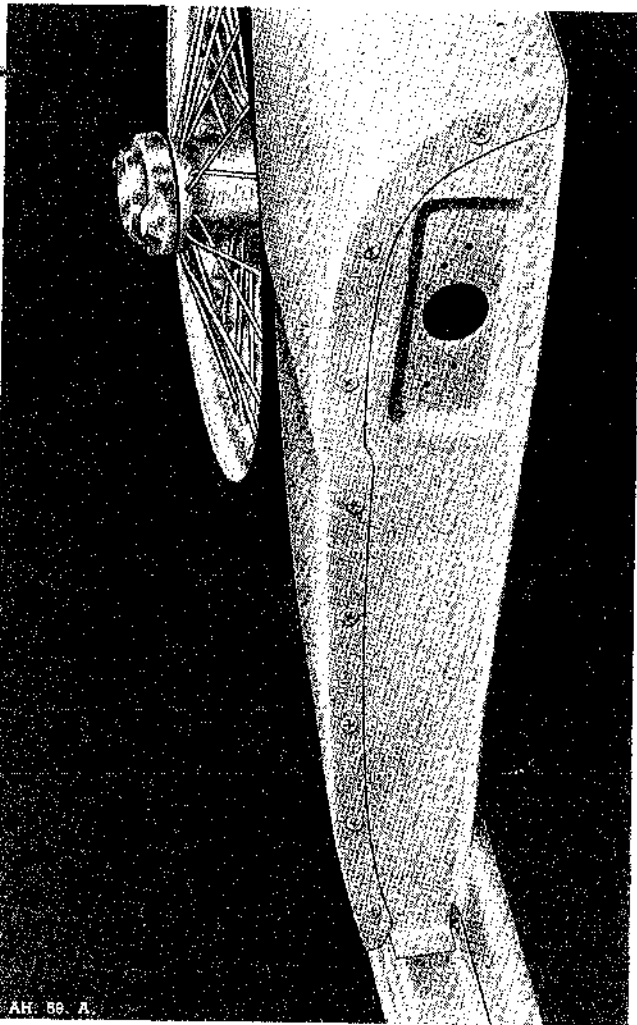

Fig. P.5 Rear wing cross-head bolts at door pillar.

### Front Wing

Remove the door concerned as described above. The next operation in dismantling a front mud-wing is to remove both the head and sidelight concerned; details of lens and reflector unit removal procedures are given in section N of this manual. The outer case of the headlamp

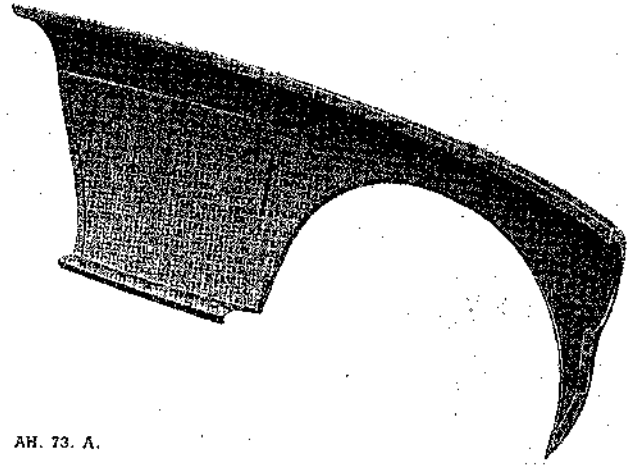

Fig. P.6. The front wing.  
Securing holes may be seen at top, bottom  
and front flanges.

is held by four bolts with brass nuts accessible beneath the wing. The sidelamps are secured by three cross-head bolts and nuts.

Beneath the headlight aperture there are three bolts which secure the wing to the cowl centre. These bolts screw into spring-clip type nuts. Along the top edge of the wing flange and forward of the scuttle, four bolts screwing into clip nuts, clamp the wing to the bonnet surround.

In the cockpit, behind the fascia, there are a further three setpins that screw into clip nuts on the wing. These  $\frac{1}{2}$  in. nuts and bolts secure the lower flange of the wing to the underside of the scuttle.

Before the wing can be finally removed there are a number of metal thread screws to be extracted that fix the wing, on the inside of the door pillar, also extract the two rivets securing the rubber water channel to the rear section of the wing.

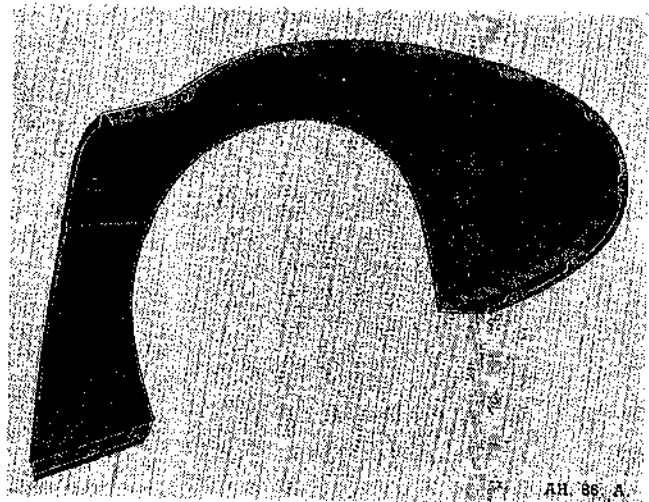

Fig. P.7. Rear wing securing flanges.

### Rear Wing

First remove the rear wheel concerned when it will be discovered that each rear wing is fixed to the main bodywork structure by six square thread bolts with spiral clip nuts which are located over the wheelarch and round the rear curve of the wing.

At the top of the wheelarch, head accessible within the luggage compartment, there is a plain nut and bolt, with washers, to be extracted. Within the cockpit, with its countersunk head hidden by the quarter casing, is another bolt screwing into a caged nut. This operation will necessitate the removal of the quarter casing.

At the lower front edge of the wing, where its flange is secured to the chassis, there are two nuts and bolts and a vertical drive screw.

To complete the wing dismantling extract the eight  $\frac{7}{16}$  in. counter sunk cross-head nuts and bolts with their plain and spring washers that fix the wing leading edge to the door pillar.

### Hood Frame

The hood frame is secured at each side to the rear quarter panel, immediately behind the seats, by two bolts, see Fig. P.8.

With these bolts withdrawn the hood frame complete with its fabric can be removed from the bodywork.

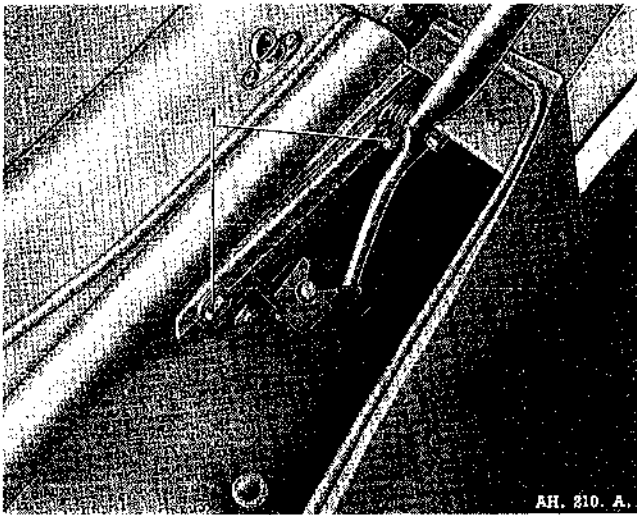

Fig. P.8. Remove the two bolts "I" in order to release the hood frame.

### Shroud

The shroud is not removed for normal maintenance work, however, if it should become necessary to remove the shroud due to damage the following fixing points must be made free.

P.4

Each outer wing half should be dismantled, see "Front Wing" also the front bumper, grille, apron, windscreen and driving mirror complete with bracket, also the cockpit moulding. In addition the bonnet top must be removed thus giving access to the fixing points around the perimeter of the opening to the engine compartment.

At the rear of the opening there are five drive screws holding the shroud to the scuttle. At the front of the bonnet opening three cross-head bolts and nuts secure the shroud to the front cross bracing of the bodywork. Still working within the opening, at each side, there are two countersunk cross-headed bolts with nuts that fix the shroud to upright braces from the chassis frame.

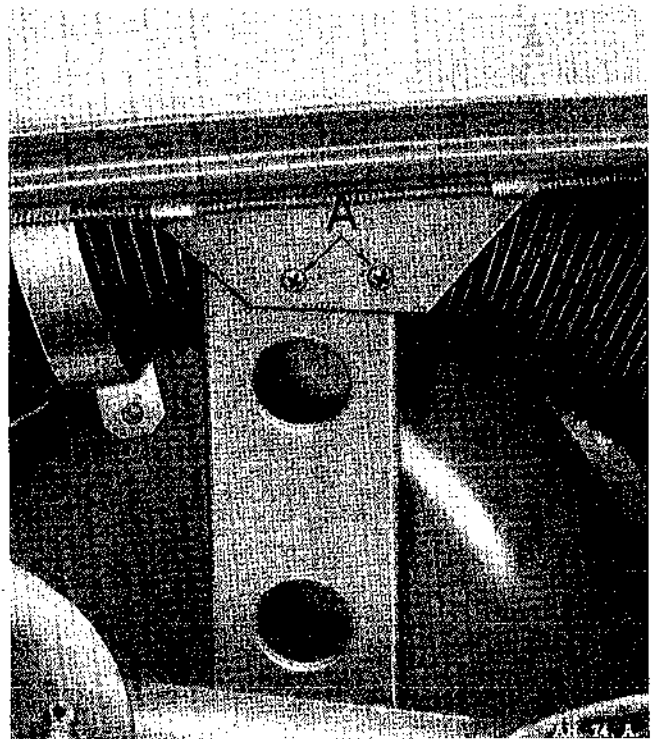
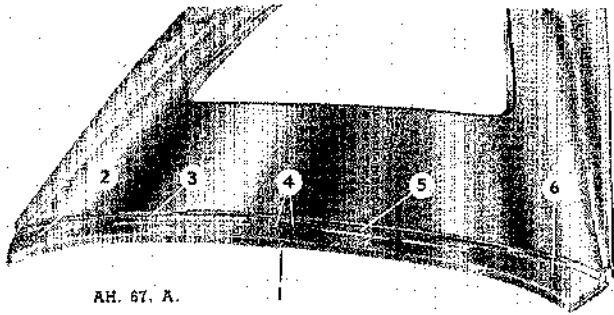

Fig. P.9. Shroud upright brace with two cross-head bolts at A.

Securing the shroud to each wheelarch panel there are two plate brackets from which the two nuts and bolts must be extracted. The cowl, which is part of the shroud, has two brackets that secure the body member to the frame dumb-irons. From these brackets extract the two nuts and bolts.

Finally free the rear end of the shroud. This is secured to the scuttle just above the fascia by five "pop" rivets, with a further "pop" rivet and two soft rivets at each side fixing the shroud to the scuttle.

The complete shroud can now be lifted clear of the frame and remainder of the bodywork.



AH. 67. A.

Fig. P.10. Shroud rear fixing.  
 1. Five "pop" rivet holes on lip.  
 2. and 6. Holes for tonneau cover studs.  
 3. and 5. Demister ducts.  
 4. Fixing holes for driving mirror.

### Gearbox Cover

The gearbox cover, or tunnel, is secured at each side flange by six metal thread screws to the floor boards. The heads of these screws are hidden from view until the carpet is peeled back.

Immediately before the tunnel there is a carpet covered bulkhead plate which can be removed for further access to gearbox and clutch housing. This is fixed to the bulkhead by six self-tapping screws.

### Fascia Panel

The first operation for removing the fascia is to drop the heater controls temporary out of the way. To do this unscrew the two round-headed bolts and nuts securing the controls to the fascia.

Remove the steering wheel as described in section K.

There are five screws, the heads of which are under the fascia, passing through the fascia panel into tapped holes of brackets behind the fascia. There is also one screw adjacent to the ignition switch. By extracting these screws the instrument panel can be brought forward into the cockpit thus giving access to the rear of each instrument.

### Grab Handle

The passenger grab handle is fixed to the fascia panel by two round head screws the heads of which are situated behind the panel.

### Seats

To adjust or remove the passenger seat the cushion must be lifted whereupon the heads of four setpins are revealed. These setpins (two each side of the seat frame) secure the seat to the body floor. On their extraction the seat may be removed or repositioned, there being four alternative holes for adjustment each side of the seat frame. For the driver an adjustable driving seat is provided for forward or rearward positioning by pushing the lever, beneath the seat, toward the runner then moving the seat to the required setting and releasing the lever.

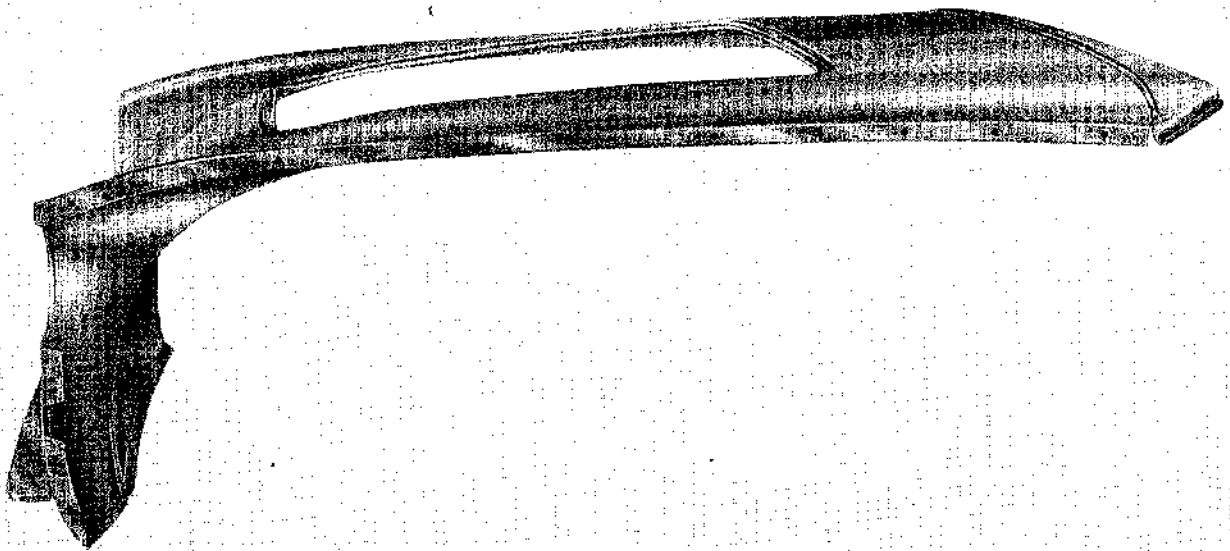

AH. 66. A.

Fig. P.11. The complete shroud, removed from the bodywork, showing the side fixings.

Lift out the seat cushion to gain access to the six nuts securing the seat to the runners.

The seat runners, with their packing pieces, are bolted to the floor, each runner having three bolts with nuts accessible beneath the floor.

**Boot Lid**

Each hinge may be disconnected from the boot lid by releasing the two hinge nuts from the underside of the lid.

The limit cable must be released from its connection under the lid.

The locking handle can be withdrawn through lock and compartment lid after its two securing screws are extracted. The round heads of these screws are visible on the underside of the lid.

Four cross-headed screws with nuts and washers fix the lock assembly to a supporting bracket riveted and welded to the lid. There is little that can go wrong with this lock, however it does benefit from the occasional application of oil particularly to the spring that is partially visible at the closing edge of the boot lid.

**Rear Body Panel**

This panel, which forms the lower rear part of the luggage compartment, is the most likely panel to suffer damage in the event of a rear collision.

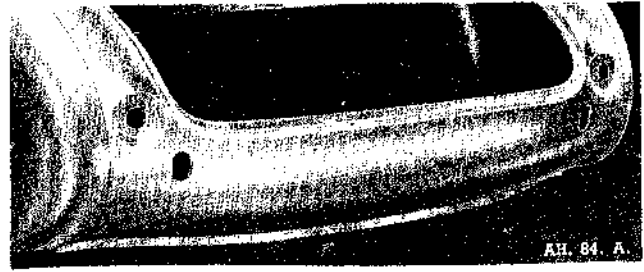

Fig. P.12. Rear body panel.  
The rivets at top and bottom lips are clearly shown.

Should the rear panel require replacing, the damaged part can be removed with a minimum amount of cutting, but a number of rivets have to be drilled out.

At each side the panel is fixed by two "pop" rivets and by two of the mud-wing nuts and bolts. The top edge of the panel has thirteen rivets holding it to the luggage compartment frame and the lower lip has nineteen rivets for securing.

After the rivets and nuts and bolts have been freed, the rear light should be removed allowing the panel to be cut along the welded seam at each side which can be felt inside the compartment.

Naturally, the new panel must be re-welded along the same lines and secured by the requisite number of rivets and nuts and bolts.

**MODIFICATION REFERENCES**

<i>Service Reference Number</i>	<i>Date</i>	<i>Subject</i>	<i>Details of Changes</i>



**SECTION Q**  
**LUBRICATION**

---

# LUBRICATION

Q

## REGULAR ATTENTIONS

A	—	B	C	D	E	—	F	G	G
Oil	Water Air	Oil	Oil Gun	Oil Can	Examine	Oil Can Grease	Oil Can Grease	Examine Adjust Clean	Oil  Oil Can Grease Examine Renew Clean
<p><b>DAILY</b></p> <p>Engine sump. Check oil level and top-up if necessary.                      Radiator. Check level and top-up if necessary.                      Check tyre pressures.</p> <p><b>1,000 MILES (1600 Km.)</b></p> <p>Gearbox, overdrive, rear axle and steering box.                      Check oil levels and top-up if necessary.                      Propeller shaft universal joints and sliding splines (3).                      Swivel axles (4).                      Suspension fulcrum pins (2).                      Steering connections (6).                      Steering idler.                      Rear spring shackle pins (2).                      Brake balance lever (1).                      Rear flexible brake cable (1).                      Handbrake, clutch and carburetter control linkage joints and steering column bush.                      Carburetter dampet assembly reservoir with S.A.E. 20 oil.                      Brake and clutch fluid reservoir levels. Top-up if necessary.                      Shock absorbers. Check for leakage.                      Brakes. Adjust if necessary.                      Battery. Top-up.</p> <p><b>3,000 MILES (5000 Km.)</b></p> <p>Engine sump. Drain and refill.                      Distributor.                      Drive shaft lubricator. Give one full turn.                      Refill every 12,000 miles.                      Fan belt. Check tension and adjust if necessary.                      Valve clearances.                      Sparking plugs and contact breaker points and adjust gaps.</p> <p><b>6,000 MILES (10000 Km.)</b></p> <p>Gearbox, overdrive and rear axle. Drain and refill. Water pump.                      Air cleaners. Clean and re-oil.                      Generator bearing with S.A.E. 30 oil.                      Front hubs.                      Shock absorbers. Check levels and top-up if necessary.                      Engine oil filter.                      Fuel system.</p> <p><b>12,000 MILES (20000 Km.)</b></p> <p>Speedometer drive cable.                      Cooling system by reverse flushing.                      Engine sump.                      Generator and starter commutators.                      Sparking plugs.                      Hubs and steering for wear.</p>									

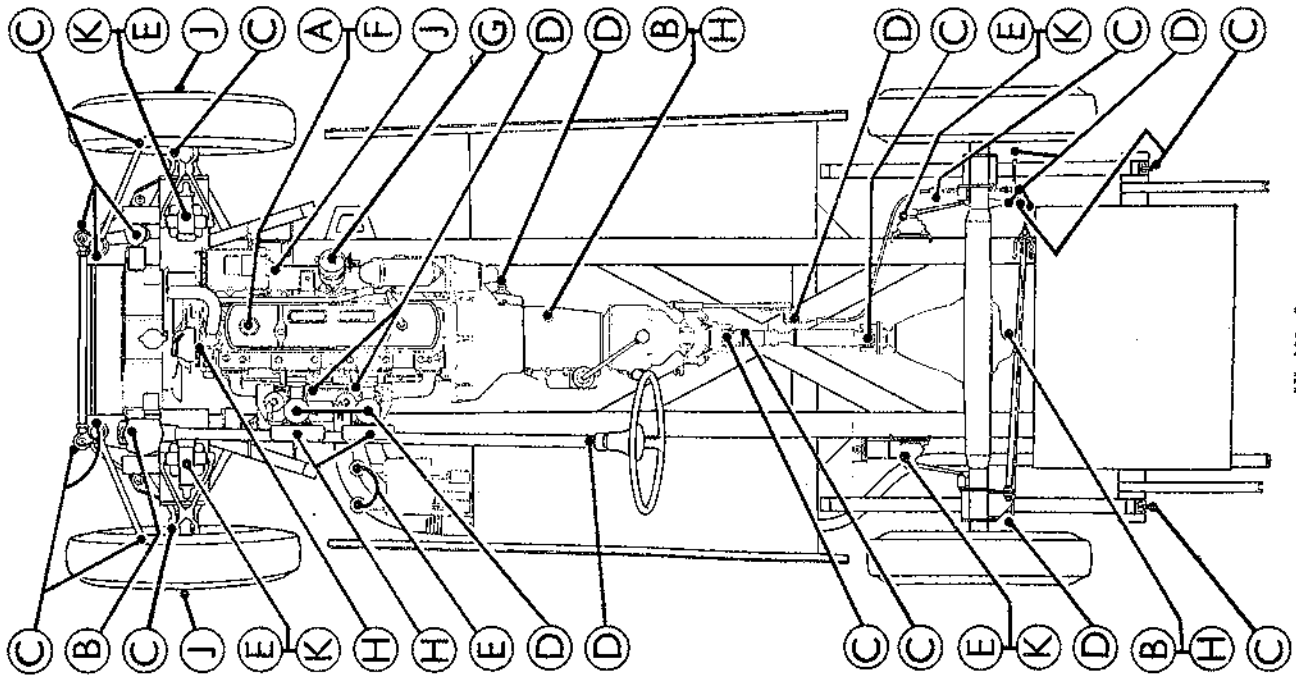

AH. 196. A.



# LUBRICATION

## RECOMMENDED LUBRICANTS

	Mobil	Shell	Filtrate	Wakefield	Esso	B.P.	Duckham's	Sternol
Engine	Above 32° F. (0° C.)	Shell X.100 30	Medium "Filtrate" 30	Castrol XL	Esso Extra Motoroil 20W/30	Energol S.A.E. 30	Duckham's "NOL THIRTY"	Sternol W.W. 30
	32° F. Down to 10° F. (0° C. to -12° C.)	Mobiloil Arctic	Zero "Filtrate" 20	Castrolite	Esso Extra Motoroil 20W/30	Energol S.A.E. 20W	Duckham's "NOL TWENTY"	Sternol W.W. 20
	Below 10° F. (-12° C.)	Mobiloil 10W	Sub-Zero "Filtrate" 10W	Castrol Z	Essolube 10	Energol S.A.E. 10W	Duckham's "NOL TEN"	Sternol W.W. 10
Transmission	Mobiloil A	Shell X.100 30	Medium "Filtrate" 30	Castrol XL	Essolube 30	Energol S.A.E. 30	Duckham's "NOL THIRTY"	Sternol W.W. 30
Rear Axle and Steering Box	Mobilube GX 90	Shell Spirax 90 E.P.	Hypoid "Filtrate" Gear 90	Castrol Hypoid	Esso ExPee Compound 90	Energol E.P.-S.A.E. 90	Duckham's Hypoid 90	Ambroleum E.P. 90
Oil Nipples	Mobilube GX 140 or Mobil Grease M.P.	Shell Spirax 140 E.P. or Relinax A	Super Lithium "Filtrate" Grease or E.P. Filtrate Gear 140	Castrol Hi-Press or Castrollease L.M.	Esso ExPee Compound 140 or Esso Multipurpose Grease	Energol E.P.-S.A.E. 140 or Energol L-3	Duckham's NOL E.P. 140 or Duckhams L.B. 10 Grease	Ambroline L.H.T. Grease or Ambroleum E.P. 140
Front Wheel Hubs	Mobil Grease M.P.	Shell Retinax A	Super Lithium "Filtrate" Grease	Castrollease L.M.	Esso Multipurpose Grease H	Energol L-3	Duckham's L.B. 10 Grease	Ambroline L.H.T. Grease
Distributor and Oil Can	Mobil Arctic	Shell X.100 20/20W	Zero "Filtrate" 20	Castrolite	Esso Extra Motoroil 20W/30	Energol S.A.E. 20W	Duckham's "NOL TWENTY"	Sternol W.W. 20
Upper Cylinder Lubrication	Mobil Upperlub	Shell Donax U	Filtrate Petroley	Wakefield Castrolite	Esso Upper Cyl. Lubricant	Energol U.C.L.	Duckham's Adcoild Liquid	Sternol Magikoyl

Rear Axle : For prevailing Sub-Zero 10° F. (-12° C.) temperatures use S.A.E. 80 Hypoid Lubricant.  
 Steering : For prevailing Sub-Zero 10° F. (-12° C.) temperatures use S.A.E. 80 Hypoid Lubricant.

Hydraulic Brakes : Use Girling Brake Fluid (Crimson).  
 Shock Absorbers : Use Armstrong's Super (Thin) Shock Absorber Oil.

### MULTIGRADE OILS

In addition to the above recommendations we approve the use of multigrade oils produced by the companies shown, for all climatic temperatures unless the engine is old or worn. Some are more expensive than the above oils because of their special properties and greater fluidity at low temperatures.